

GMR Sensors Data Book

April 2003

Applications for NVE GMR Sensors

- Position of Pneumatic Cylinders
- Position in Robotics Applications
- Speed and Position of Bearings
- Speed and Position of Electric Motor Shafts
- General Field Detection in Implantable Medical Devices
- Wheel Speed Sensing for ABS Brake Applications
- Transmission Gear Speed Sensing for Shift Control
- Low Field Detection in Currency Applications
- Current Sensing in PCB Traces and Wires
- Overcurrent and Short Circuit Detection
- Vehicle Detection for Traffic Counting Applications
- Magnetic Encoder Detection for Secure Safe Applications
- Position Sensing for Shock Absorber Feedback Control
- Earth's Field Detection for Revolution Counting

Introduction to NVE GMR Sensors	2
GMR Materials Overview	3
Basic Sensor Design.....	5
Signal Processing.....	8
AA and AB Series Analog Sensors	10
Quick Reference: AA and AB Series.....	11
AA Sensors	12
AAH Sensors	14
AAL Sensors.....	16
AB Sensors	18
ABH Sensors	20
GMR Switch™ Precision Digital Sensors	22
Quick Reference: GMR Switch Digital Sensors	23
GMR Switch Product Selection Guide.....	24
AD0xx-xx to AD7xx-xx	30
AD8xx-xx to AD9xx-xx	34
ADH0xx-xx.....	38
GT Sensors™	40
ABL Sensors.....	41
AKL Sensors	47
Application Notes for GT Sensors	50
Circuit Board Sensor Products.....	57
AG20x-07 Cylinder Position Sensors	57
AG Series Currency Detection Sensors.....	59
Peripheral Integrated Circuits	61
DB Series Power Switch ICs.....	62
DC Series Voltage Regulators.....	66
DD Series Signal Processing ICs.....	68
Evaluation Kits.....	71
Analog Sensor and Current Sensor Evaluation Kits.....	72
GMR Switch and GT Sensor Evaluation Kits.....	74
Appendix	76
Package Drawings and Specifications.....	76
Part Numbers and Marking Codes.....	78
Definitions and Conversion Factors.....	79

Introduction to NVE GMR Sensors

In 1988, scientists discovered the “Giant Magneto Resistive” effect – a large change in electrical resistance that occurs when thin stacked layers of ferromagnetic and non-magnetic materials are exposed to a magnetic field. Since then, many companies have sought to develop practical applications for this intriguing technology. NVE Corporation has taken the lead by developing the first commercially available products making use of GMR technology, a line of magnetic field sensors that outperform traditional Hall Effect and AMR magnetic sensors.

NVE introduced its first analog sensor product in 1995. Since then, our product line has grown to include several variations on analog sensors, the GMR Switch™ line of precision digital sensors, and our newest products, the GT Sensors™ for gear tooth and encoder applications. In addition to these products, NVE offers printed circuit board assemblies for pneumatic cylinder position and currency detection applications, as well as peripheral integrated circuits designed to work with our GMR sensors in a variety of applications. Finally, NVE remains committed to custom product developments for large and small customers, in order to develop the best possible sensor for the customer’s application.

NVE magnetic sensors have significant advantages over Hall Effect and AMR sensors, as shown in the following chart. In virtually every application, NVE sensors outperform the competition – often at a significantly lower installed cost.

Benefits:	GMR	HALL	AMR
Physical Size	Small	Small	Large
Signal Level	Large	Small	Medium
Sensitivity	High	Low	High
Temperature Stability	High	Low	Medium
Power Consumption	Low	Low	High
Cost	Low	Low	High

GMR Materials Overview

The heart of NVE's sensor products are the proprietary GMR materials produced in our factory. These materials are manufactured in our on-site cleanroom facility, and are based on nickel, iron, cobalt, and copper. Various alloys of these materials are deposited in layers as thin as 15 angstroms (5 atomic layers!), and as thick as 18 microns, in order to manufacture the GMR sensor elements used in NVE's products.

The following diagrams show how the GMR effect works in NVE's sensors. Note that the material is sensitive in the plane of the IC, rather than orthogonally to the IC, as is the case with Hall elements.

No External Magnetic Field

High Resistance

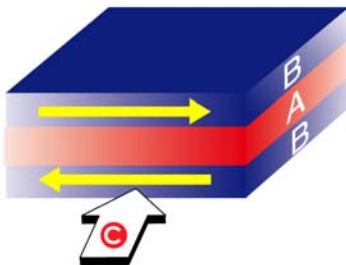

A Is a conductive, nonmagnetic interlayer. Magnetic moments in alloy **B** layers face opposite directions due to the anti-ferromagnetic coupling. Resistance to current **C** is high.

External Magnetic Field

Low Resistance

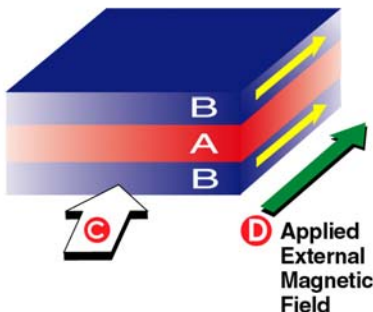

Applying external magnetic field **D** over comes anti-ferromagnetic coupling, aligning magnetic moments in alloy **B** layers. Electrical resistance drops dramatically; 10% to 15% is typical.

NVE's GMR materials are noteworthy in comparison with other GMR material types in that NVE's material cannot be damaged with the application of extremely large magnetic fields. GMR materials from other sources rely on keeping one of the magnetic layers internally magnetized, or pinned, in a specific direction, and allowing the other layer to rotate and thus provide the GMR effect. An external magnetic field as small as 200 Gauss can upset this pinned layer, thus permanently damaging the sensor element. Since NVE's materials rely on anti-ferromagnetic coupling between the layers, they are not affected by extremely large fields, and will resume normal operation after the large field is removed.

The following chart shows a typical characteristic for an NVE GMR material:

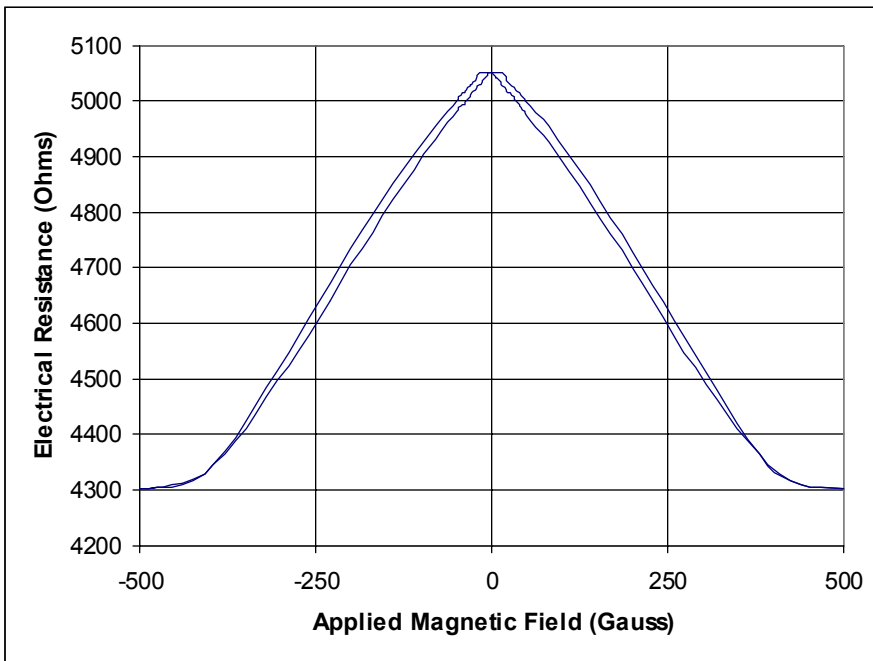

Notice that the output characteristic is omnipolar, meaning that the material provides the same change in resistance for a directionally positive magnetic field as it does for a directionally negative field. This characteristic has advantages in certain applications. For example, when used on a magnetic encoder wheel, a GMR sensor using this material will provide a complete sine wave output for each pole on the encoder (rather than each pole pair, as with a Hall Effect sensor), thus doubling the resolution of the output signal.

The material shown in the plot is used in most of NVE's GMR sensor products. It provides a 98% linear output from 10% to 70% of full scale, a large GMR effect (13% to 16%), a stable temperature coefficient (0.15%/°C) and temperature tolerance (+150°C), and a large magnetic field range (0 to ±300 Gauss).

In addition to manufacturing this excellent material, NVE is constantly developing new GMR materials. New products have recently been introduced which use two new materials, one with double the magnetic sensitivity of the standard material, and one with half the magnetic hysteresis. Both of these new materials are suitable for operation up to +225°C.

With constant emphasis on developing new and improved GMR materials, and frequent new product releases utilizing these improvements, NVE continues to lead the market in GMR-based magnetic sensors.

Basic Sensor Design

NVE manufactures two basic sensor element types: magnetometers, which detect the strength of the applied magnetic field, and gradiometers (or differential sensors), which detect the magnetic field gradient across a certain distance.

Magnetometers

NVE's magnetometers are covered by our basic GMR material and sensor structure patents, and have unique features designed to take advantage of the characteristics of GMR sensor materials. A photomicrograph of an NVE sensor element is shown below:

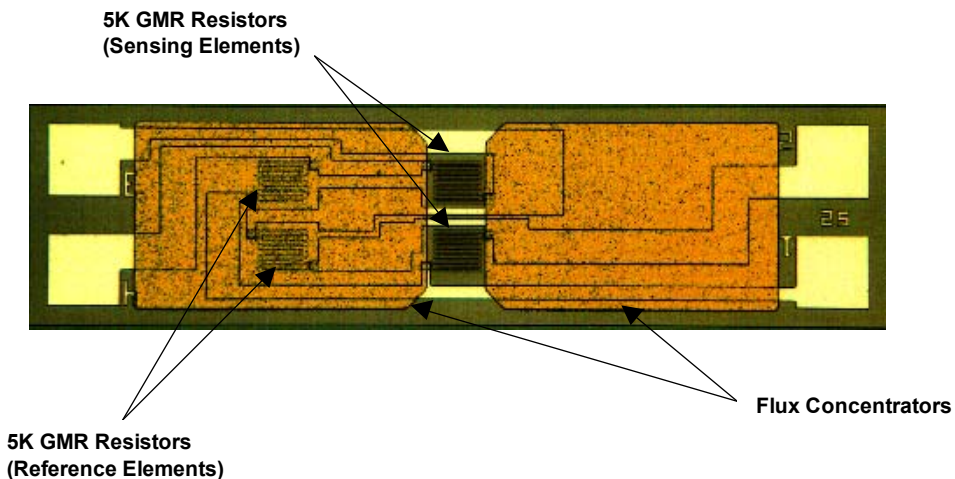

The size of this IC is approximately 350 microns by 1400 microns. The sensor is configured as a Wheatstone bridge. The serpentine structures in the center of the die, and to the left of center under the large plated structure, are 5K resistors made of GMR material.

The two large plated structures shown on the die are flux concentrators. They serve two purposes. First, notice that they cover two of the resistors in the Wheatstone bridge. In this configuration the flux concentrators function as a shield for these two resistors, preventing an applied magnetic field from reaching them. Therefore, when a field is applied, the two GMR resistors in the center of the die decrease in resistance, while the two GMR resistors under the flux concentrator do not. This imbalance leads to the bridge output.

The second purpose of the flux concentrators is to vary the sensitivity of the sensor element from product to product. They work by forming a low reluctance path to the sensor elements placed between them. NVE uses a “rule of thumb” formula to calculate the effect of the flux concentrators:

$$\text{Field at sensor elements} \cong (\text{Applied Field})(60\%)(\text{FC length} / \text{gap between FCs})$$

For the sensor shown in the previous photo, the length of each flux concentrator is 400 microns, and the gap between the flux concentrators is 100 microns. Therefore, if the sensor is exposed to an applied field of 10 Gauss, the actual field at the sensor element will be about (10 Gauss)(0.6)(400 microns / 100 microns), or 24 Gauss.

NVE uses this technique to provide GMR sensors with varying sensitivity to the applied magnetic field. The following chart shows sensitivity ranges for some of NVE’s products. Sensitivity to the magnetic field is indicated by the slope of each line:

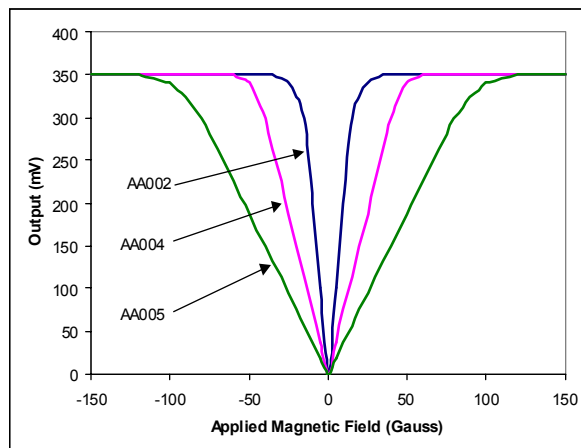

Maximum signal output from such a sensor element is typically 350mV at 100 Gauss with a 5V supply. This compares to an output of 5mV under the same conditions for a Hall sensor element, and 100mV for an AMR sensor.

Gradiometers

NVE's gradiometers, or differential sensors, rely on the field gradient across the IC to generate an output. In fact, if one of these sensors is placed in a uniform magnetic field, its output voltage will be zero. This is because all four of the bridge resistors are exposed to the same magnetic field, so they all change resistance together. There is no shielding or flux concentration on a gradiometer. A simple representation of a gradiometer is shown in the diagram below:

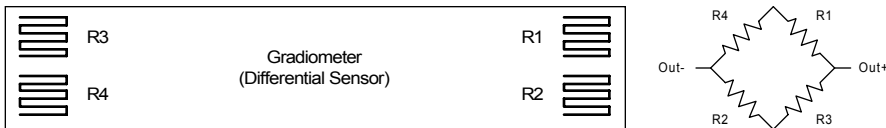

Because all four bridge resistors are able to contribute to the sensor's output, at maximum differential field NVE's gradiometers can provide double the output signal of our magnetometer parts, or about 700mV with a 5V supply. In actual practice the gradient fields are typically not high enough to give this maximum signal, but signal levels of 50mV to 200mV are common.

NVE's GMR differential sensors are typically designed with two of the bridge resistors at one end of the IC, and two at the other end. The spacing between the two sets of resistors, combined with the magnetic field gradient on the IC, will determine the output signal from the sensor element. NVE offers two standard spacings for differential sensors: 0.5mm and 1.0mm. If a different spacing is desired, contact NVE for development cost and schedule for a custom product.

The most popular application for differential sensors is in gear tooth or magnetic encoder detection. As these structures move or spin, the magnetic field near their surface is constantly varying, generating a field gradient. A differential sensor, properly placed, can detect this movement by sensing the changing field gradient, and provide an output for each gear tooth or each magnetic pole (see the GT Sensor section of this catalog for a more detailed explanation). Applications for these devices include detecting the speed and position of electric motor shafts or bearings, automotive transmission gear speeds or axle shaft speed in Anti-lock Braking Systems (ABS), or linear gear tooth position.

Signal Processing

Adding signal processing electronics to the basic sensor element increases the functionality of NVE's sensors. The large output signal of the GMR sensor element means less circuitry, smaller signal errors, less drift, and better temperature stability compared to sensors where more amplification is required to create a usable output.

For the GMR Switch products, NVE adds a simple comparator and output transistor circuit to create the world's most precise digital magnetic sensor. For these products, no amplification of the sensor's output signal is necessary. A block diagram of this circuitry is shown in the figure below:

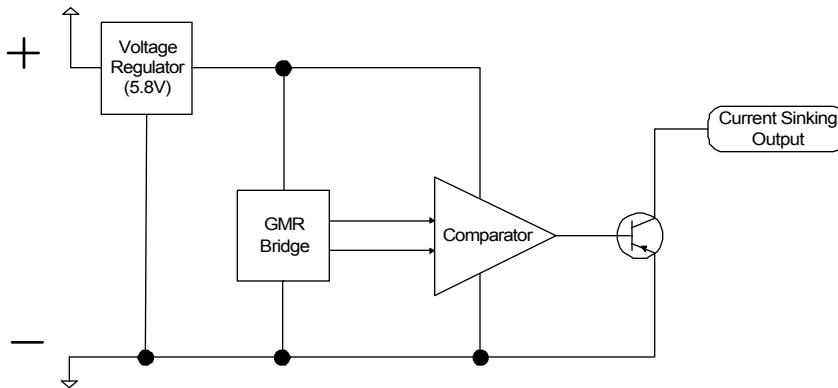

The GMR Switch holds its precise magnetic operate point over extreme variations in temperature and power supply voltage. This low cost product has revolutionized the industrial control position sensing market.

Taking this approach one step further, NVE's integrated GT Sensor products add low gain amplification and magnet compensation circuitry to the basic sensor element to create a powerful gear tooth and encoder sensor at an affordable price.

NVE also offers certain peripheral IC products, to help customers integrate GMR sensor elements into their systems, and meet rigorous regulatory agency requirements for safety and survivability. These products include power switch ICs for switching large currents in industrial applications, and voltage regulator ICs for reducing wide ranging automotive and industrial voltage supplies to manageable IC-friendly levels. Both of these product types retain a "bulletproof" appearance to the outside electrical world, and resist damage from high voltage transients, reverse battery connections, and ESD/EMC events.

For applications where a unique product is required, NVE's in-house IC design group regularly does custom designs for our customers. These designs range from simple variations on NVE's existing parts to full custom chips for one of a kind applications. For applications where a unique electronic functionality is required, please contact NVE.

AA and AB Series Analog Sensors

NVE’s AA and AB Series analog GMR sensors offer unique and unparalleled magnetic sensing capabilities. These sensors are characterized by high sensitivity to applied magnetic fields, excellent temperature stability, low power consumption, and small size. These characteristics make them suitable for use in a wide variety of applications, from rugged industrial and automotive position, speed, and current sensors, to low voltage, battery-powered sensors for use in hand-held instrumentation and implantable medical devices. The unmatched versatility of these basic magnetic sensors makes them an excellent choice for a wide range of analog sensing applications.

The AA series sensors use NVE’s patented GMR materials and on-chip flux concentrators to provide a directionally sensitive output signal. These sensors are sensitive in one direction in the plane of the IC, with a cosine-scaled falloff in sensitivity as the sensor is rotated away from the sensitive direction. Also, these devices provide the same output for magnetic fields in the positive or negative direction along the axis of sensitivity (omnipolar output). All sensors are designed in a Wheatstone bridge configuration to provide temperature compensation. Two packages are offered, an SOIC8 and an MSOP8. These sensors are also available in die form on a special order basis.

Three families of NVE’s basic AA series sensors are offered: the standard AA series, the AAH series, and the AAL series. Each of these sensor families uses a different GMR material, with its own characteristics. The comparison table below summarizes the different characteristics of the GMR materials:

	AA Series	AAH Series	AAL Series
Sensitivity to Applied Fields	High	Very High	High
Field Range of Operation	High	Low	Medium
Hysteresis	Medium	High	Low
Temperature Range	High	Very High	Very High

The AB series sensors are differential sensor devices, or gradiometers, which take advantage of the high output characteristics of NVE’s GMR materials. Two families of AB sensors are offered: the standard AB series, and the ABH series. They have operational characteristics similar to the AA and AAH sensors described in the table above, but with the bipolar linear output characteristics of a differential sensor.

Within these different sensor families, customers can find an excellent match to their analog sensor requirements.

Quick Reference: AA and AB Series

For comparison and product selection purposes, the following table lists all available AA and AB series analog sensors, with some of their key characteristics:

Magnetometers:

Part Number	Linear Range (Oe ¹)		Sensitivity (mV/V-Oe ¹)		Maximum Non-linearity (% Uni. ²)	Maximum Hysteresis (% Uni. ²)	Maximum Operating Temp (°C)	Typical Resistance (Ohms)	Package
	Min	Max	Min	Max					
AA002-02	1.5	10.5	3.0	4.2	2	4	125	5K	SOIC8
AA003-02	2.0	14	2	3.2	2	4	125	5K	SOIC8
AA004-00	5.0	35	0.9	1.3	2	4	125	5K	MSOP8
AA004-02	5.0	35	0.9	1.3	2	4	125	5K	SOIC8
AA005-02	10.0	70	0.45	0.65	2	4	125	5K	SOIC8
AA006-00	5.0	35	0.9	1.3	2	4	125	30K	MSOP8
AA006-02	5.0	35	0.9	1.3	2	4	125	30K	SOIC8
AAH002-02	0.6	3.0	7.5	13.0	4	15	150	2K	SOIC8
AAH004-00	1.5	7.5	3.2	4.8	4	15	150	2K	MSOP8
AAL002-02	1.5	10.5	3.0	4.2	2	2	150	5.5K	SOIC8

Gradiometers:

Part Number	Linear Range (Oe ¹)		Resistor Spacing (mm)	Maximum Non-linearity (% Uni. ²)	Maximum Hysteresis (% Uni. ²)	Maximum Operating Temp (°C)	Typical Resistance (Ohms)	Package
	Min	Max						
AB001-02	20	200	0.5	2	4	125	2.5K	SOIC8
AB001-00	20	200	0.5	2	4	125	2.5K	MSOP8
ABH001-02	5	40	0.5	4	15	150	1.2K	SOIC8
ABH001-00	5	40	0.5	4	15	150	1.2K	MSOP8

Notes:

- 1 Oersted (Oe) = 1 Gauss in air.
2. Unipolar operation means exposure to magnetic fields of one polarity, for example 0 to +30 Gauss, or -2 to -50 Gauss. Bipolar operation (for example -5 to + 10 Gauss) will increase nonlinearity and hysteresis.

AA Sensors

Features:

- ⇒ Excellent Sensitivity to Applied Magnetic Fields
- ⇒ Wheatstone Bridge Analog Output
- ⇒ Operating Temperature to 125°C Continuous
- ⇒ Wide Linear Range of Operation
- ⇒ Near-Zero Voltage Operation
- ⇒ DC to >1MHz Frequency Response
- ⇒ Small, Low Profile Surface Mount Packages

Applications:

- ⇒ General Motion, Speed, and Position Sensing
- ⇒ Low Power, Low Voltage Applications
- ⇒ Low Field Sensing for Magnetic Media Detection
- ⇒ Current Sensing

Description:

The basic AA series GMR sensors are general purpose magnetometers for use in a wide variety of applications. They exhibit excellent linearity, a large output signal with applied magnetic fields, stable and linear temperature characteristics, and a purely ratiometric output.

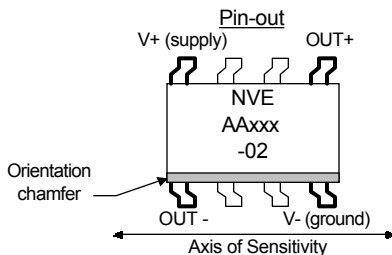

Functional Block Diagram

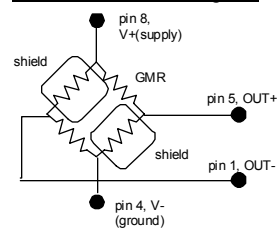

Magnetic Characteristics:

Part Number	Saturation Field (Oe ¹)	Linear Range (Oe ¹)		Sensitivity (mV/V-Oe ¹)		Resistance (Ohms)	Package ²	Die Size ³ (μm)
		Min	Max	Min	Max			
AA002-02	15	1.5	10.5	3.0	4.2	5K ± 20%	SOIC8	436x3370
AA003-02	20	2.0	14	2	3.2	5K ± 20%	SOIC8	436x3370
AA004-00	50	5	35	0.9	1.3	5K ± 20%	MSOP8	411x1458
AA004-02	50	5	35	0.9	1.3	5K ± 20%	SOIC8	411x1458
AA005-02	100	10	70	0.45	0.65	5K ± 20%	SOIC8	411x1458
AA006-00	50	5	35	0.9	1.3	30K ± 20%	MSOP8	836x1986
AA006-02	50	5	35	0.9	1.3	30K ± 20%	SOIC8	836x1986

General Characteristics:

Property	Min	Typical	Max	Unit
Input Voltage Range	<1 ⁴		± 25 ⁴	Volts
Operating Frequency	DC		> 1	MHz
Operating Temperature Range	-50		125	°C
Bridge Electrical Offset	-4		+4	mV/V
Signal Output at Max. Field		60		mV/V
Nonlinearity			2	% (unipolar) ⁵
Hysteresis			4	% (unipolar) ⁵
TCR		+0.14		% / °C ⁶
TCOI		+0.03		% / °C ⁶
TCOV		-0.1		% / °C ⁶
Off Axis Characteristic		Cos β ⁷		
ESD Tolerance		400		V pin to pin HBM

Notes:

1. 1 Oersted (Oe) = 1 Gauss in air.
2. See the Appendix for package dimensions and tolerances.
3. Sensors can be provided in die form by special request.
4. GMR AA Series sensors are pure ratiometric devices, meaning that they will operate properly at extremely low supply voltages. The output signal will be proportional to the supply voltage. Maximum voltage range is limited by the power dissipation in the package and the maximum operating temperature of the sensor.
5. Unipolar operation means exposure to magnetic fields of one polarity, e.g., 0 to 30 Gauss, or -2 to -50 Gauss, but not -20 to +30 Gauss (bipolar operation). Bipolar operation will increase nonlinearity and hysteresis.
6. TCR is resistance change with temperature with no applied field. TCOI is the output change with temperature using a constant current source to power the sensor. TCOV is the output change with temperature using a constant voltage source to power the sensor. See the graphs below.
7. Beta (β) is any angle from the sensitive axis.

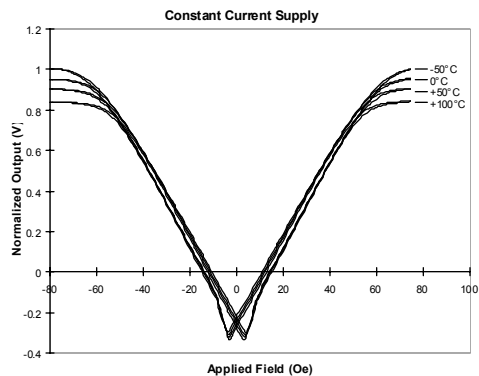
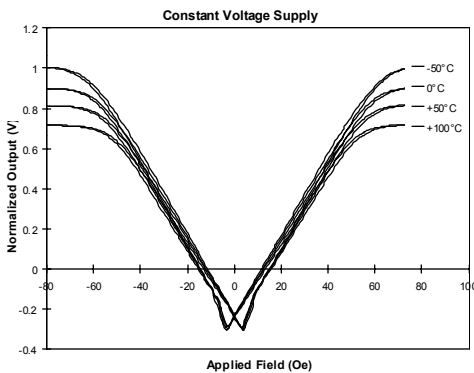

AAH Sensors

Features:

- ⇒ Extremely High Sensitivity to Applied Magnetic Fields
- ⇒ Wheatstone Bridge Analog Output
- ⇒ Temperature Tolerance to 150°C Continuous
- ⇒ Near-Zero Voltage Operation
- ⇒ DC to >1MHz Frequency Response
- ⇒ Small, Low Profile Surface Mount Packages

Applications:

- ⇒ Low Voltage, High Temperature Applications
- ⇒ Low Field Sensing for Magnetic Media Detection
- ⇒ Earth's Magnetic Field Detection
- ⇒ Current Sensing

Description:

The AAH series GMR sensors are manufactured with a high sensitivity GMR material, making them ideally suited for any low magnetic field application. They are also extremely temperature tolerant, to +150°C operating temperatures.

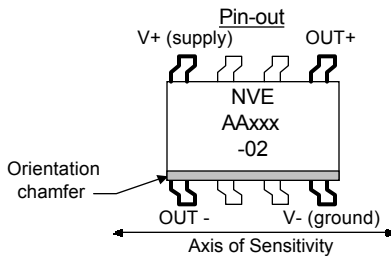

Functional Block Diagram

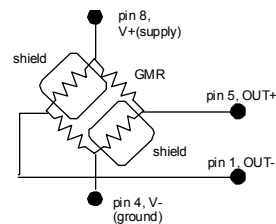

Magnetic Characteristics:

Part Number	Saturation Field (Oe ¹)	Linear Range (Oe ¹)		Sensitivity (mV/V-Oe ¹)		Resistance (Ohms)	Package ²	Die Size ³ (μm)
		Min	Max	Min	Max			
AAH002-02	6	0.25	3.0	7.5	13.0	2K ± 20%	SOIC8	436x3370
AAH004-00	15	0.5	7.5	3.2	4.8	2K ± 20%	MSOP	411x1458

General Characteristics:

Property	Min	Typical	Max	Unit
Input Voltage Range	<1 ⁴		± 25 ⁴	Volts
Operating Frequency	DC		> 1	MHz
Operating Temperature Range	-50		150	°C
Bridge Electrical Offset	-4		+4	mV/V
Signal Output at Max. Field		40		mV/V
Nonlinearity		4		% (unipolar) ⁵
Hysteresis		15		% (unipolar) ⁵
TCR		+0.30		% / °C ⁶
TCOI		-0.28		% / °C ⁶
TCOV		-0.40		% / °C ⁶
Off Axis Characteristic		Cos β ⁷		
ESD Tolerance		400		V pin to pin HBM

Notes:

1. 1 Oersted (Oe) = 1 Gauss in air.
2. See the Appendix for package dimensions and tolerances.
3. Sensors can be provided in die form by special request.
4. GMR AAH Series sensors are pure ratiometric devices, meaning that they will operate properly at extremely low supply voltages. The output signal will be proportional to the supply voltage. Maximum voltage range is limited by the power dissipation in the package and the maximum operating temperature of the sensor.
5. Unipolar operation means exposure to magnetic fields of one polarity, e.g. 0 to 30 Gauss, or -2 to -50 Gauss, but not -20 to +30 Gauss (bipolar operation). Bipolar operation will increase nonlinearity and hysteresis.
6. TCR is resistance change with temperature with no applied field. TCOI is the output change with temperature using a constant current source to power the sensor. TCOV is the output change with temperature using a constant voltage source to power the sensor.
7. Beta (β) is any angle from the sensitive axis.

Typical Outputs:

AAH002-02

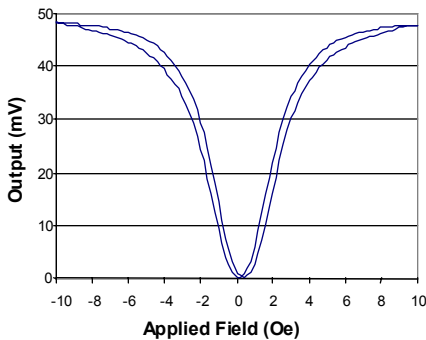

AAH004-00

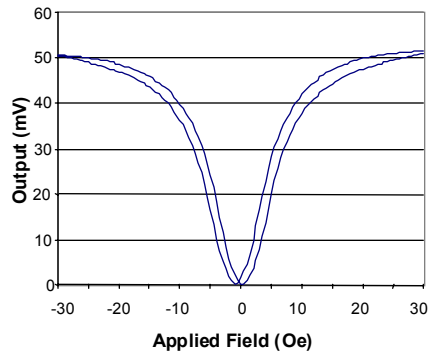

AAL Sensors

Features:

- ⇒ Excellent Sensitivity to Applied Magnetic Fields
- ⇒ Wheatstone Bridge Analog Output
- ⇒ Temperature Tolerance to 150°C Continuous
- ⇒ Very Low Magnetic Hysteresis
- ⇒ Near-Zero Voltage Operation
- ⇒ DC to >1MHz Frequency Response
- ⇒ Small, Low Profile Surface Mount Packages

Applications:

- ⇒ General Motion, Speed, and Position Sensing
- ⇒ Low Voltage, High Temperature Applications
- ⇒ Low Field Sensing for Magnetic Media Detection
- ⇒ Current Sensing

Description:

The AAL series GMR sensors are manufactured with a low hysteresis GMR material, for use in magnetometer applications where minimum hysteresis is important. They are also extremely temperature tolerant, to +150C operating temperatures.

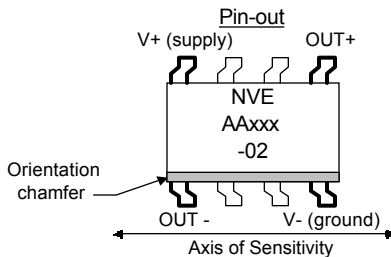

Functional Block Diagram

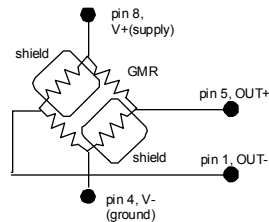

Magnetic Characteristics:

Part Number	Saturation Field (Oe ¹)	Linear Range (Oe ¹)		Sensitivity (mV/V-Oe ¹)		Resistance (Ohms)	Package ²	Die Size ³ (μm)
		Min	Max	Min	Max			
AAL002-02	15	1.5	10.5	3.0	4.2	5.5K ± 20%	SOIC8	436x3370

General Characteristics:

Property	Min	Typical	Max	Unit
Input Voltage Range	<1 ⁴		± 25 ⁴	Volts
Operating Frequency	DC		> 1	MHz
Operating Temperature Range	-50		150	°C
Bridge Electrical Offset	-4		+4	mV/V
Signal Output at Max. Field		45		mV/V
Nonlinearity			2	% (unipolar) ⁵
Hysteresis			2	% (unipolar) ⁵
TCR		+0.30		% / °C ⁶
TCOI		-0.28		% / °C ⁶
TCOV		-0.40		% / °C ⁶
Off Axis Characteristic		Cos β ⁷		
ESD Tolerance		400		V pin to pin HBM

Notes:

1. 1 Oersted (Oe) = 1 Gauss in air.
2. See the Appendix for package dimensions and tolerances.
3. Sensors can be provided in die form by special request.
4. GMR AAL Series sensors are pure ratiometric devices, meaning that they will operate properly at extremely low supply voltages. The output signal will be proportional to the supply voltage. Maximum voltage range is limited by the power dissipation in the package and the maximum operating temperature of the sensor.
5. Unipolar operation means exposure to magnetic fields of one polarity, e.g. 0 to 30 Gauss, or -2 to -50 Gauss, but not -20 to +30 Gauss (bipolar operation). Bipolar operation will increase nonlinearity and hysteresis.
6. TCR is resistance change with temperature with no applied field. TCOI is the output change with temperature using a constant current source to power the sensor. TCOV is the output change with temperature using a constant voltage source to power the sensor.
7. Beta (β) is any angle from the sensitive axis.

Typical Outputs:

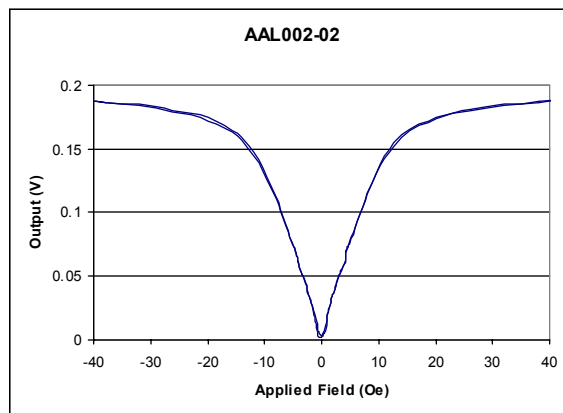

AB Sensors

Features:

- ⇒ Excellent Sensitivity to Applied Magnetic Fields
- ⇒ Wheatstone Bridge Analog Output
- ⇒ Temperature Tolerance to 125°C Continuous
- ⇒ Wide Linear Range of Operation
- ⇒ Near-Zero Voltage Operation
- ⇒ DC to >1MHz Frequency Response
- ⇒ Small, Low Profile Surface Mount Packages

Applications:

- ⇒ General Differential Field Sensing
- ⇒ Gear Tooth and Encoder Speed and Position Sensing
- ⇒ Low Power, Low Voltage Applications

Description:

The AB series GMR sensors are general purpose gradiometers for use in a wide variety of applications. Two pairs of unshielded GMR sensor elements provide for directional sensing of small gradients in large and small magnetic fields. The ability to detect only magnetic gradients allows low sensitivity to external sources of uniform magnetic field, allowing these sensors to work successfully in high magnetic noise environments, such as near electric motors or current carrying wires.

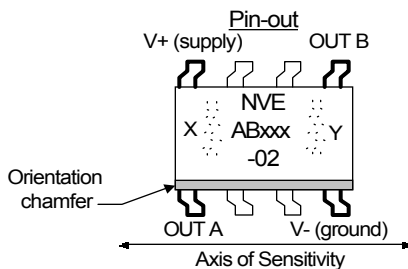

Functional Block diagram

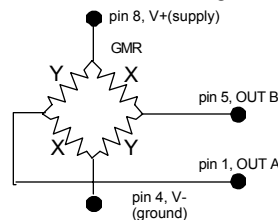

Magnetic Characteristics:

Part Number	Saturation Field (Oe ¹)	Linear Range ((Oe ¹))		Resistor Sensitivity (%R / Oe ¹)		Resistance (Ohms)	Package ²	Die Size ³ (µm)
		Min	Max	Min	Max			
AB001-02	250	20	200	0.02	0.03	2.5K+/-20%	SOIC8	651x1231
AB001-00	250	20	200	0.02	0.03	2.5K+/-20%	MSOP8	651x1231

General Characteristics:

Property	Min	Typical	Max	Unit
Input Voltage Range	<1 ⁴		±12.5 ⁴	Volts
Operating Frequency	DC		> 1	MHz
Operating Temperature Range	-50		125	°C
Bridge Electrical Offset	-4		+4	mV/V
Signal Output at Max. Field		120		mV/V
Nonlinearity			2	% (unipolar) ⁵
Hysteresis			4	% (unipolar) ⁵
TCR		+0.14		% / °C ⁶
TCOI		+0.03		% / °C ⁶
TCOV		-0.1		% / °C ⁶
Off Axis Characteristic		Cos β ⁷		
ESD Tolerance		400		V pin to pin HBM

Notes:

1. 1 Oersted (Oe) = 1 Gauss in air.
2. See the Appendix for package dimensions and tolerances.
3. Sensors can be provided in die form by special request.
4. GMR AB Series sensors are pure ratiometric devices, meaning that they will operate properly at extremely low supply voltages. The output signal will be proportional to the supply voltage. Maximum voltage range is limited by the power dissipation in the package and the maximum operating temperature of the sensor.
5. Unipolar operation means exposure to magnetic fields of one polarity, e.g. 0 to 30 Gauss, or -2 to -50 Gauss, but not -20 to +30 Gauss (bipolar operation). Bipolar operation will increase nonlinearity and hysteresis.
6. TCR is resistance change with temperature with no applied field. TCOI is the output change with temperature using a constant current source to power the sensor. TCOV is the output change with temperature using a constant voltage source to power the sensor.
7. Beta (β) is any angle from the sensitive axis.

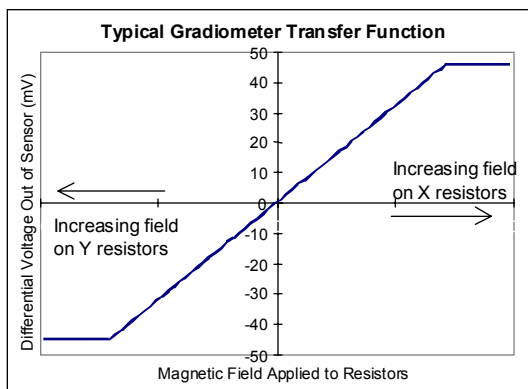

The Figure to the left is a simulated output from an NVE Gradiometer. The output / gradient correlation shown assumes one pair of resistors is held at zero field. Note the bipolar output.

ABH Sensors

Features:

- ⇒ Extremely High Sensitivity to Applied Magnetic Fields
- ⇒ Wheatstone Bridge Analog Output
- ⇒ Temperature Tolerance to 150°C Continuous
- ⇒ Wide Linear Range of Operation
- ⇒ Near-Zero Voltage Operation
- ⇒ DC to >1MHz Frequency Response
- ⇒ Small, Low Profile Surface Mount Packages

Applications:

- ⇒ General Differential Field Sensing
- ⇒ Gear Tooth and Encoder Speed and Position Sensing
- ⇒ Low Voltage, High Temperature Applications

Description:

The ABH series GMR sensors are low field, high temperature gradiometers for use in a wide variety of applications. Two pairs of unshielded GMR sensor elements provide for directional sensing of small gradients in large and small magnetic fields. The ability to detect only magnetic gradients allows low sensitivity to external sources of uniform magnetic field, allowing these sensors to work successfully in high magnetic noise environments, such as near electric motors or current carrying wires.

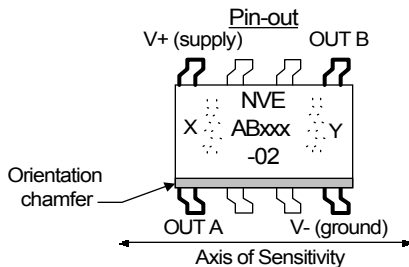

Functional Block diagram

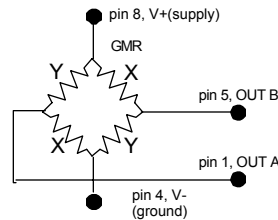

Magnetic Characteristics:

Part Number	Saturation Field (Oe ¹)	Linear Range ((Oe ¹))		Resistor Sensitivity (%R / Oe ¹)		Resistance (Ohms)	Package ²	Die Size ³ (µm)
		Min	Max	Min	Max			
ABH001-02	70	5	40	0.06	0.12	1.2K+/-20%	SOIC8	651x1231
ABH001-00	70	5	40	0.06	0.12	1.2K+/-20%	MSOP8	651x1231

General Characteristics:

Property	Min	Typical	Max	Unit
Input Voltage Range	<1 ⁴		± 12.5 ⁴	Volts
Operating Frequency	DC		> 1	MHz
Operating Temperature Range	-50		150	°C
Bridge Electrical Offset	-4		+4	mV/V
Signal Output at Max. Field		80		mV/V
Nonlinearity			4	% (unipolar) ⁵
Hysteresis			15	% (unipolar) ⁵
TCR		+0.30		% / °C ⁶
TCOI		-0.28		% / °C ⁶
TCOV		-0.40		% / °C ⁶
Off Axis Characteristic		Cos β ⁷		
ESD Tolerance		400		V pin to pin HBM

Notes:

1. 1 Oersted (Oe) = 1 Gauss in air.
2. See the Appendix for package dimensions and tolerances.
3. Sensors can be provided in die form by special request.
4. GMR AB Series sensors are pure ratiometric devices, meaning that they will operate properly at extremely low supply voltages. The output signal will be proportional to the supply voltage. Maximum voltage range is limited by the power dissipation in the package and the maximum operating temperature of the sensor.
5. Unipolar operation means exposure to magnetic fields of one polarity, e.g. 0 to 30 Gauss, or -2 to -50 Gauss, but not -20 to +30 Gauss (bipolar operation). Bipolar operation will increase nonlinearity and hysteresis.
6. TCR is resistance change with temperature with no applied field. TCOI is the output change with temperature, using a constant current source to run the sensor. TCOV is the output change with temperature, using a constant voltage source to run the sensor.
7. Beta (β) is any angle from the sensitive axis.

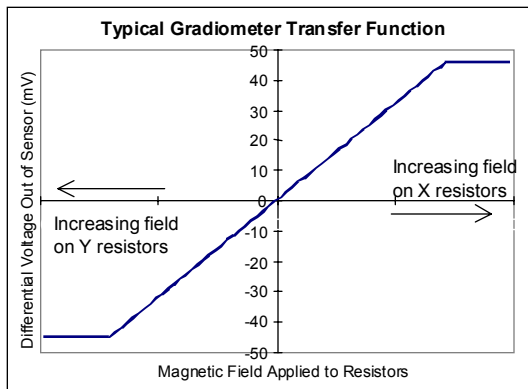

The Figure to the left is a simulated output from an NVE Gradiometer. The output / gradient correlation shown assumes one pair of resistors is held at zero field. Note the bipolar output.

GMR Switch™ Precision Digital Sensors

When GMR sensor elements are combined with digital on-board signal processing electronics, the result is the GMR Switch. The GMR Switch offers unmatched precision and flexibility in magnetic field sensing.

The GMR Switch will accurately and reliably sense magnetic fields with less error than any other magnetic sensor on the market today. In addition, there is little shift in the magnetic field operate point of the GMR switch over voltage and temperature extremes. This gives NVE's customer the ability to make a high precision, high tolerance magnetic sensing assembly.

The GMR switch can operate over a wide range of magnetic fields, and is the most precise magnetic sensor on the market. It is the clear choice when a digital output signal is required of a magnetic sensor.

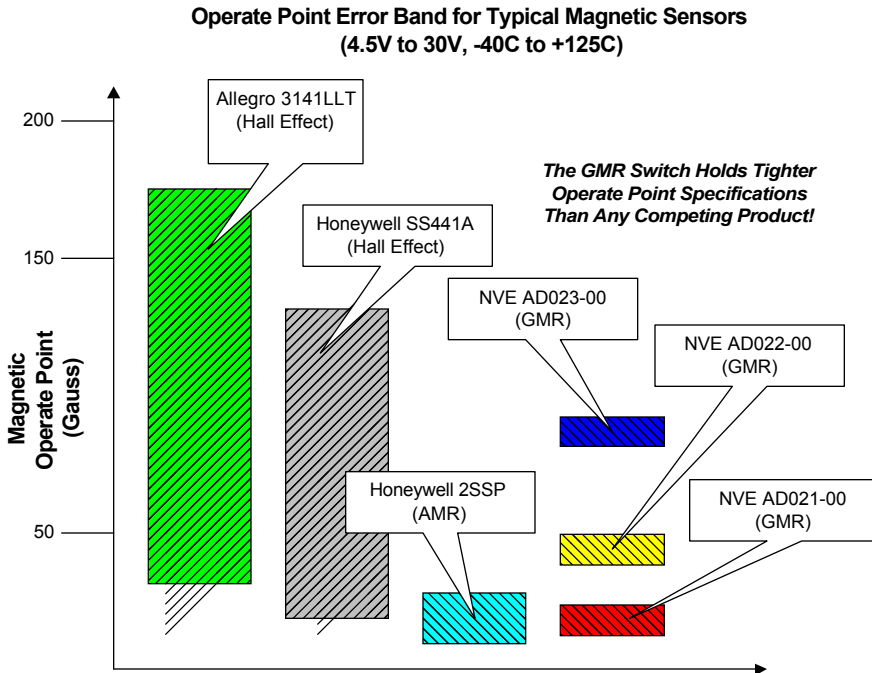

Quick Reference: GMR Switch Digital Sensors

The following table lists some of NVE's most popular GMR Switch products and their key specifications:

Part Number	Typical Magnetic Operate Point (Oe ¹)	Typical Magnetic Release Point (Oe ¹)	Output Type ²	Maximum Operation Temperature (°C)	Package Type ³
NVE AD004-02	20	10	Sink	125	SOIC8
NVE AD005-02	40	25	Sink	125	SOIC8
NVE AD021-00	20	10	Sink	125	MSOP8
NVE AD022-00	40	25	Sink	125	MSOP8
NVE AD024-00	28	14	Sink	125	MSOP8
NVE AD124-00	28	14	Source	125	MSOP8
NVE AD621-00	20	10	Sink + Source	125	MSOP8
NVE AD824-00	28	14	2 Sinks + SCP	125	MSOP8
NVE ADH025-00	11	5	Sink	150	MSOP8

Notes:

1. 1 Oersted (Oe) = 1 Gauss in air
2. Output Types:
 Sink = Up to 20mA current sink
 Source = Up to 20mA current source
 SCP = Short Circuit Protection available for external transistor
3. See Appendix for package dimensions

Note on Availability of Products

NVE keeps about 25 of the most popular types of GMR Switch products in stock at our manufacturing facility. However, because there are over 100 different varieties of GMR Switch parts, some part numbers may require a 6 to 8 week lead time before production quantities are available. Please contact NVE for further information.

GMR Switch Product Selection Guide

NVE's GMR Switch is available in a wide range of packaging, output type, and magnetic trigger field varieties. The purpose of this selection guide is to explain the different output and packaging options, as well as to provide information on how to specify the correct part number when ordering.

All NVE GMR Switch product part numbers follow the same general form. As shown below, the first "x" in the part number specifies output type and available voltage regulator output, the next two x's specify trigger field and direction of sensitivity, and the last pair specify the package type. The following sections define these variations in detail.

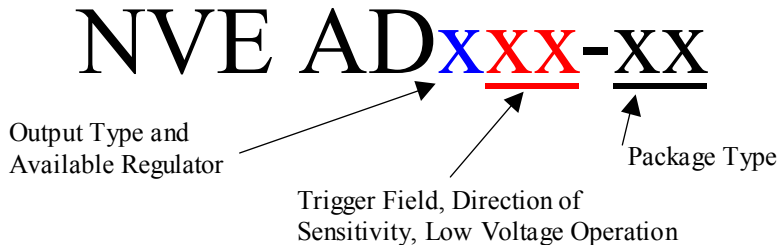

Output Type and Available Regulator

The first numeric digit of the part number ADxxx-xx specifies the output type, and the availability of a regulated voltage supply on a separate pin. The following four output types are available:

- 20 mA Current Sink
- 20 mA Current Source
- Separate 20 mA Sink and Source
- Two Separate 20 mA Sinks

All outputs turn ON when the magnetic field is applied. An output that turns OFF when the magnetic field is applied is available as a custom product; please consult NVE.

Some of NVE's GMR Switch products also feature a regulated supply voltage available external to the part on a separate pin. This regulator provides a 5.8V reference capable of supplying up to 3 mA of drive current. This regulated output may be used to run an LED or other low power device.

In addition to these options, NVE recently introduced a GMR Switch that has provisions for shutting down an external power transistor in case a short circuit is detected. This is useful in applications where the finished sensor assembly must be “bulletproof,” or immune to improper connection.

The following table defines the first digit in NVE AD part numbers:

NVE AD x xx-xx

Number	Meaning
0	20mA Current Sink
1	20 mA Current Source
2	Separate 20mA Current Sink and 20mA Current Source
3	Two Separate 20mA Current Sinks
4	20mA Current Sink + Regulated Output Voltage
5	20 mA Current Source + Regulated Output Voltage
6	Separate 20mA Current Sink and 20mA Current Source + Regulated Output Voltage
7	Two Separate 20mA Current Sinks + Regulated Output Voltage
8	Two Separate 20mA Current Sinks + Regulated Output Voltage + Short Circuit Detection and Shut-Off
9	Separate 20mA Current Sink and 20mA Current Source + Regulated Output Voltage + Short Circuit Detection and Shut-Off

Trigger Field, Direction of Sensitivity, Low Voltage Operation

The second and third numeric digits of the part number ADxxx-xx specify the magnetic trigger field and direction of sensitivity of the part. Five different magnetic trigger fields are available for the GMR Switch:

- 10 Gauss (10 Oe, 1.0 mT, 0.8 kA/m)
- 20 Gauss (20 Oe, 2.0 mT, 1.6 kA/m)
- 28 Gauss (28 Oe, 2.8 mT, 2.23 kA/m)
- 40 Gauss (40 Oe, 4.0 mT, 3.2 kA/m)
- 80 Gauss (80 Oe, 8.0 mT, 6.4 kA/m)

Other magnetic trigger field levels ranging up to 250 Gauss are available on a custom basis; please contact NVE.

In addition to defining the magnetic operate point, these two digits are used to define the direction of sensitivity and optional low voltage operation. The GMR Switch can be ordered in Standard Axis or Cross Axis directions of sensitivity; for definitions please see AD Series Sensitivity Direction and Pin Configuration later in this section.

NVE also makes a GMR Switch with the on-chip voltage regulator bypassed. This limits the voltage range of the part, but allows it to operate at voltages as low as 3.0V.

The following table defines the second and third digits in the NVE AD part number:

NVE AD x xx-xx

Number	Meaning
04	20 Gauss OP, Standard Direction of Sensitivity
05	40 Gauss OP, Standard Direction of Sensitivity
06	80 Gauss OP, Standard Direction of Sensitivity
20	28 Gauss OP, Standard Direction of Sensitivity
21	20 Gauss OP, Cross Axis Direction of Sensitivity
22	40 Gauss OP, Cross Axis Direction of Sensitivity
23	80 Gauss OP, Cross Axis Direction of Sensitivity
24	28 Gauss OP, Cross Axis Direction of Sensitivity
25	10 Gauss OP, Cross Axis Direction of Sensitivity (ADH Series Only; see page 38)
81	20 Gauss OP, Cross Axis Direction of Sensitivity, Low Volt
82	40 Gauss OP, Cross Axis Direction of Sensitivity, Low Volt
83	80 Gauss OP, Cross Axis Direction of Sensitivity, Low Volt
84	28 Gauss OP, Cross Axis Direction of Sensitivity, Low Volt

Note: For parts that operate at 10 Gauss, see the following section describing the ADH Series sensors.

AD Series Sensitivity Direction and Pin Configuration

Pin configuration for the NVE AD Series GMR Switches is given in the following diagrams. In addition, most GMR Switch parts are available with a choice of two directions of sensitivity. “Standard” direction of sensitivity is defined as the direction parallel to the edge of the package containing the pins. “Cross-Axis” direction of

sensitivity is defined as the direction perpendicular to the edge of the package containing the pins. Pin configuration and sensitivity direction is defined in the drawings below:

NVE AD0xx-xx through NVE AD7xx-xx, NVE ADH0xx-xx:



Note: In the case of a Standard Axis Part with the Vreg pin option, Sink(1) will appear at the pin labelled N/C*

NVE AD8xx-xx through NVE AD9xx-xx:



Package Type

NVE GMR Switches are available in three different packages: an SOIC 8 pin package, an MSOP 8 pin small outline package, and a TDFN 6 pin ultra-miniature package. Package drawings are shown in the Appendix.

The following table defines the last two digits in the NVE AD part number:

NVE AD x xx-xx

Number	Package Type
00	MSOP8
02	SOIC8
10 ¹	TDFN6

Note¹: At this time, the TDFN6 package is only available in AD0xx-10 configuration.

In addition to these three package types, NVE offers a custom version of the MSOP8 package for the NVE AD024-00 part. In this version, the BD012-00, all three connections are made on one side of the package, and the pins on the other side of the package are clipped off flush with the body of the package. This allows the user to position the sensing element as close to the edge of a circuit board or assembly as possible. A pinout of this package is shown below:

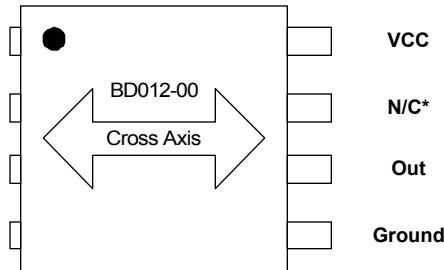

The maximum length of the clipped leads is 0.30mm, leading to an overall package length of 4.25mm, as compared to 4.90mm for the normal MSOP8 package. This part is available in tape and reel format only.

Other versions of the GMR Switch may be available in this package configuration on a special order basis. Please contact NVE for further information.

Characteristics Over Voltage and Temperature

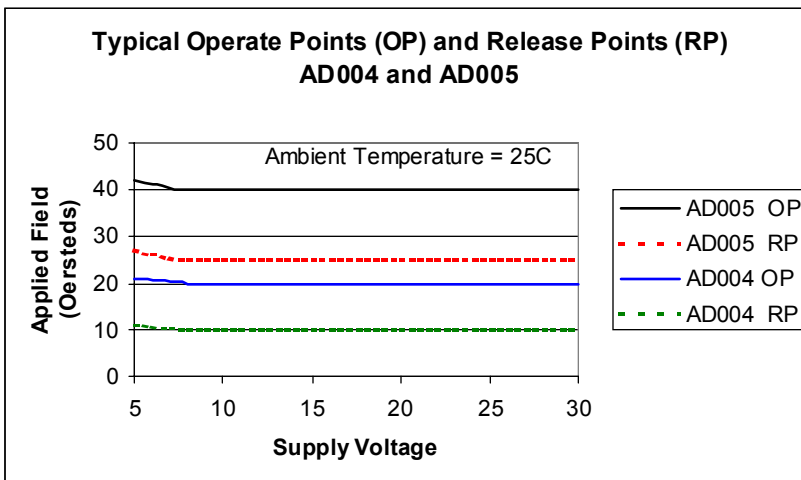

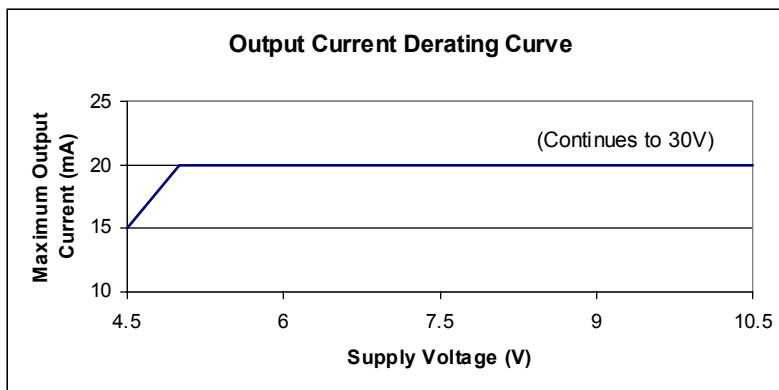
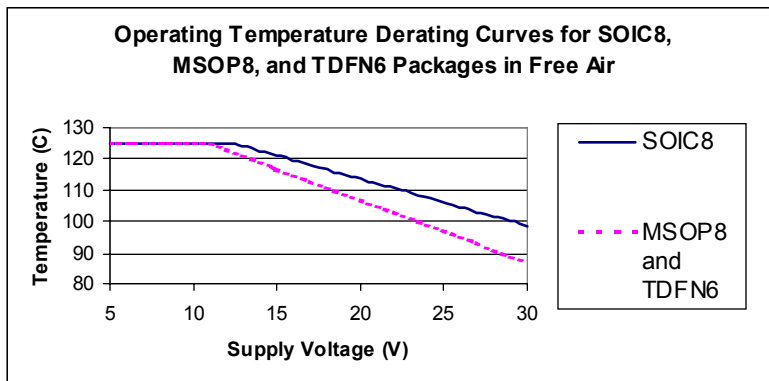
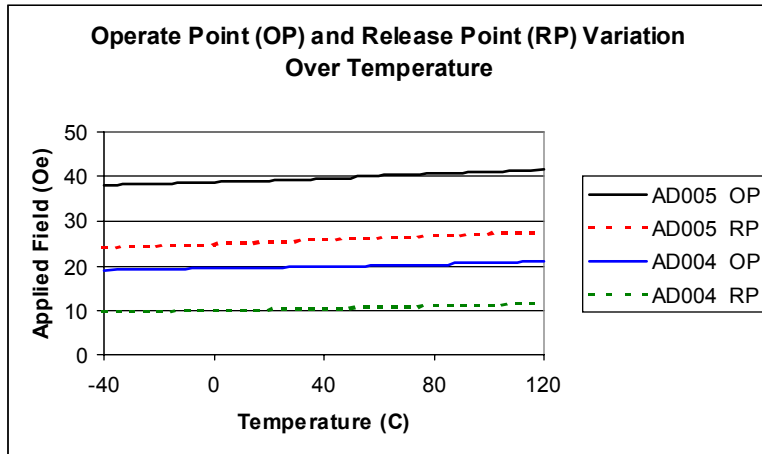

AD0xx-xx to AD7xx-xx

Features:

- ⇒ Precision Magnetic Operate Point
- ⇒ Excellent Temperature and Voltage Performance
- ⇒ Digital Outputs
- ⇒ Frequency Response 0 to 250KHz
- ⇒ Optional Voltage Regulator Output
- ⇒ Optional Low Voltage Version
- ⇒ Small, Low Profile Surface Mount Packages

Applications:

- ⇒ General Digital Position Sensing
- ⇒ Pneumatic Cylinder Position Sensing
- ⇒ Speed Sensing

Description:

The NVE AD0xx-xx to AD7xx-xx GMR Switches are digital output magnetometers that offer precision operate points over all temperature and input voltage conditions. They are available with magnetic trigger fields from 20 to 80 Gauss, and four different output configurations, making them an extremely flexible and user-friendly design.

Functional Block Diagram (NVE AD0xx-xx to NVE AD7xx-xx, Except NVE AD08x-xx):

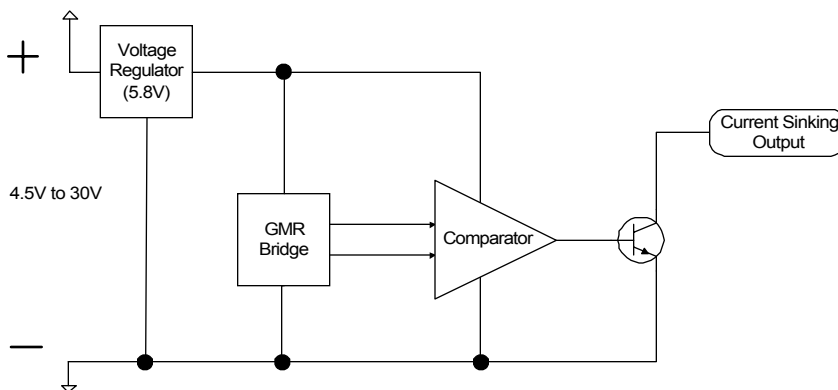

Functional Block Diagram (NVE AD08x-xx):

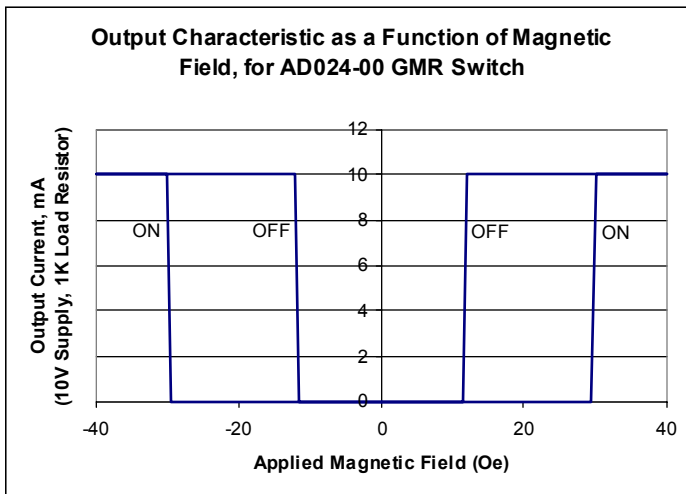
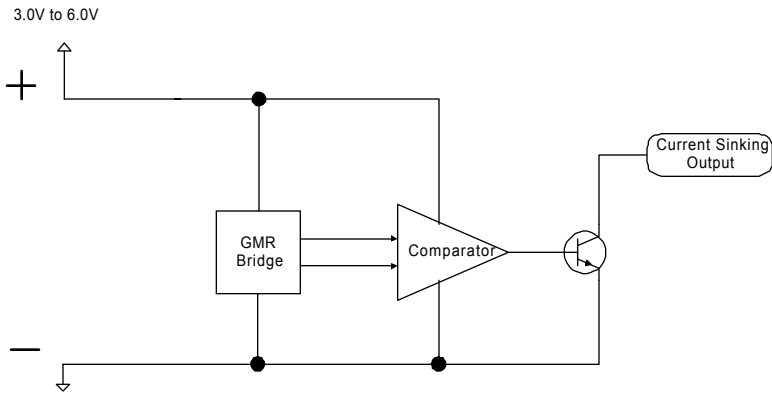

Magnetic Characteristics:

Typical Operate Point	Minimum Operate Point	Maximum Operate Point	Minimum Differential ^{1,2}	Maximum Differential ^{1,2}
20	15	25	5	14
28	21	34	5	20
40	30	50	5	25
80	60	100	5	35

Note: All Values in Oersteds (Oe); 1 Oe = 1 Gauss in Air

Electrical Specifications (NVE AD0xx-xx to NVE AD7xx-xx, except NVE AD08x-xx):

Parameter	Symbol	Min	Max	Units	Test Condition
Supply Voltage ⁴	V _{CC}	4.5	30	V	Operating
Supply Current, Single Output	I _{CC}	2.5	4.5	mA	Output Off, V _{CC} =12V
Current Sinking Output ³	I _O	0	20	mA ³	Operating
Current Sourcing Output ³	I _O	0	20	mA ³	Operating
Output Leakage Current	I _{LEAK}		10	μA	Output Off, V _{CC} =12V
Sinking Output Saturation Voltage	V _{OL}		0.4	V	Output On, I _{OL} =20mA
Sourcing Output Saturation Voltage	V _{OH}		V _{CC} -2.5	V	Output On, I _{OL} =20mA
Regulated Output Voltage ⁵	V _{REG}	3.5	6.0	V	Operating
Regulated Output Current	I _{REG}		3.0	mA	Operating

Electrical Specifications (NVE AD08x-xx):

Parameter	Symbol	Min	Max	Units	Test Condition
Supply Voltage	V _{CC}	3.0	6.0	V	Operating
Supply Current, Single Output	I _{CC}	0.7	1.2	mA	Output Off, V _{CC} =3V
Supply Current, Single Output	I _{CC}	1.7	2.2	mA	Output Off, V _{CC} =6V
Current Sinking Output ²	I _O	0	20	mA ³	Operating
Output Leakage Current	I _{LEAK}		10	μA	Output Off, V _{CC} =5V
Sinking Output Saturation Voltage	V _{OL}		0.4	V	Output On, I _{OL} =20mA

Absolute Maximum Ratings (NVE AD0xx-xx to NVE AD7xx-xx, except NVE AD08x-xx):

Parameter	Symbol	Min	Max	Units
Supply Voltage	V _{CC}		33	V
Reverse Battery Voltage	V _{RBP}		-33	V
Current Sinking Output Off Voltage			33	V
Current Sourcing Output Off Voltage			0	V
Current Sinking Reverse Output Voltage			-0.5	V
Current Sourcing Reverse Output Voltage			-0.5	V
Continuous Output Current	I _O		24	mA
Operating Temperature Range ⁴	T _A	-40	125	°C
Storage Temperature Range	T _S	-65	150	°C
Magnetic Field ⁵	H		None	Oe

Absolute Maximum Ratings (NVE AD08x-xx):

Parameter	Symbol	Min	Max	Units
Supply Voltage	V_{CC}		7	V
Reverse Battery Voltage	V_{RBP}		-0.5	V
Current Sinking Output Off Voltage			33	V
Current Sinking Reverse Output Voltage			-0.5	V
Continuous Output Current	I_o		24	mA
Operating Temperature Range ⁴	T_A	-40	125	°C
Storage Temperature Range	T_S	-65	150	°C
Magnetic Field ⁵	H		None	Oe

Notes:

- Differential = Operate Point – Release Point
- Minimum Release Point for AD0xx-xx to AD7xx-xx, except AD08x-xx, = 5 Oe. Minimum Release Point for AD08x-xx = 3.5 Oe.
- Output current must be limited by a series resistor. Exceeding absolute maximum continuous output current ratings will result in damage to the part. See the figure in the GMR Switch Product Selection Guide for an output current derating curve.
- Thermal power dissipation for the packages used by NVE is 240°C/Watt for the SOIC8 package, and 320°C/Watt for the MSOP8 and TDFN6 packages. See the Figure on Ambient Temperature vs. Supply Voltage for derating information. Heat sinking the parts by attaching them to a PCB improves temperature performance.
- There is no maximum magnetic field that will cause damage to the device.
- If $V_{CC} > 6.6V$, $V_{REG} = 5.8V$. If $V_{CC} < 6.6V$, $V_{REG} = V_{CC} - 0.9V$.

AD8xx-xx to AD9xx-xx

Features:

- ⇒ Short Circuit Detection and Shutoff of External Power Transistor
- ⇒ Precision Magnetic Operate Point
- ⇒ Excellent Temperature and Voltage Performance
- ⇒ Digital Outputs
- ⇒ Frequency Response 0 to 250KHz
- ⇒ Small, Low Profile Surface Mount Packages

Applications:

- ⇒ General Digital Position Sensing
- ⇒ Pneumatic Cylinder Position Sensing
- ⇒ Speed Sensing

Description:

NVE AD8xx and AD9xx GMR Switches are designed specifically for use with an external high current output transistor in industrial control environments. These parts provide the same precise magnetic performance NVE’s GMR Switch is known for, with the additional functionality of short circuit protection (SCP) for the output stage of the circuit. The protection circuit is designed to shut off the output stage when a short circuit condition exists; after a time interval specified by the user, the circuit turns back on. If the short circuit condition still exists, the output stage is again shut off and the cycle repeats. The use of this sensor, along with external reverse battery protection and overvoltage protection, results in a “bulletproof” sensor assembly. A functional block diagram of this sensor is shown below:

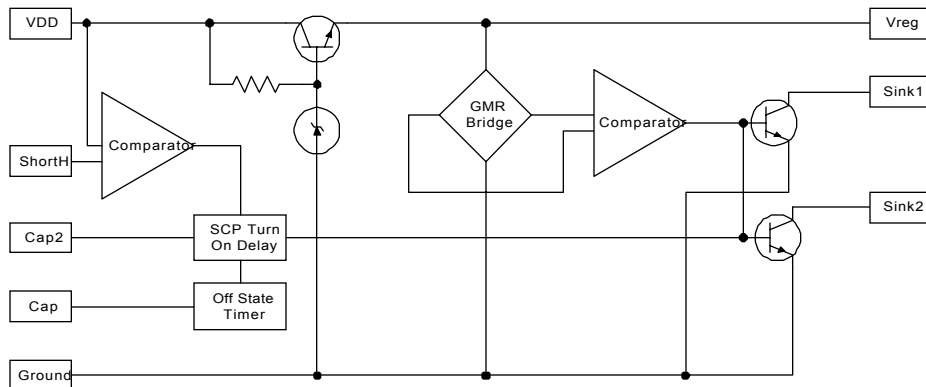

These digital sensors with SCP are available for use with current sinking or current sourcing outputs, in a range of magnetic field operate points. They are provided in an MSOP8 package, with the cross-axis direction of sensitivity. An LED driver to indicate the presence of the magnetic field is also standard on these products. An SOIC8 package and standard axis sensitivity are available on a special order basis.

Typical Circuit Configuration:

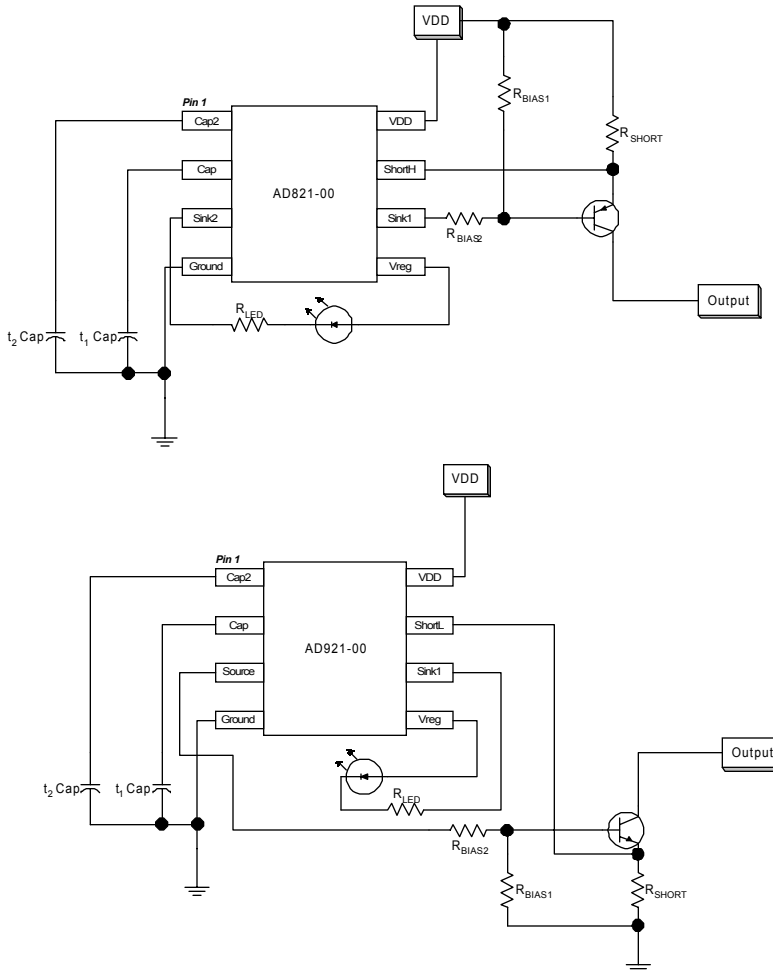

Output Transistor Current in Short Circuit mode:

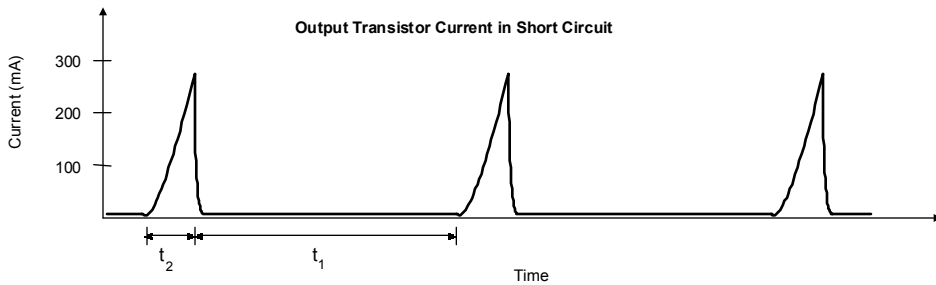

Notes:

1. The t_2 Cap is used to delay the startup of the SCP circuitry, in order to avoid triggering the SCP circuitry on normal startup transients: see t_2 on the graph above. Typical value is 16V, 0.001 μ F, for a 35 μ s delay.
2. The t_1 Cap is used to set the “Off” time of the SCP circuitry; see t_1 on the graph above. Typical value is 16V, 0.01 μ F, for a 15ms Off time.
3. The voltage across R_{SHORT} is monitored by the IC; if this voltage exceeds 145mV (typical), the SCP circuitry is activated. Typical value of R_{SHORT} is 0.47 Ohms, 1/16 watt. This will result in SCP circuitry turning on at about 300mA of output current.
4. R_{BIAS1} and R_{BIAS2} are used to bias the output transistor. Typical values for R_{BIAS1} and R_{BIAS2} are 16K and 3K, respectively, to supply 1mA drive to the output transistor.
5. R_{LED} is sized for whatever LED current is required by the user; maximum of 3 mA.

Magnetic Characteristics:

Typical Operate Point	Minimum Operate Point	Maximum Operate Point	Minimum Differential ^{1,2}	Maximum Differential ^{1,2}
20	15	25	5	14
28	21	34	5	20
40	30	50	5	25
80	60	100	5	35

Note: All Values in Oersteds (Oe); 1 Oe = 1 Gauss in Air

Electrical Specifications:

Parameter	Symbol	Min	Max	Units	Test Condition
Supply Voltage ⁴	V _{CC}	4.5	30	V	Operating
Supply Current	I _{CC}	1.75	3.5	mA	Output Off, V _{CC} =12V
Current Sinking Output ²	I _O	0	2.0	mA ³	Operating
Current Sourcing Output ²	I _O	0	2.0	mA ³	Operating
Output Leakage Current	I _{LEAK}		10	μA	Output Off, V _{CC} =12V
Sinking Output Saturation Voltage	V _{OL}		0.4	V	Output On, I _{OL} =2mA
Sourcing Output Saturation Voltage	V _{OH}		V _{CC} -2.0	V	Output On, I _{OL} =2mA
Regulated Output Voltage ⁶	V _{REG}	3.5	6.0	V	Operating
Regulated Output Current	I _{REG}		3.0	mA	Operating
Short High Voltage	ShortH	0.12	0.17	V	Output On
Short Low Voltage	ShortL	0.12	0.17	V	Output On

Absolute Maximum Ratings:

Parameter	Symbol	Min	Max	Units
Supply Voltage	V _{CC}		33	V
Reverse Battery Voltage	V _{RBP}		-0.5	V
Current Sinking Output Off Voltage			33	V
Current Sourcing Output Off Voltage			0	V
Current Sinking Reverse Output Voltage			-0.5	V
Current Sourcing Reverse Output Voltage			-0.5	V
Continuous Output Current	I _O		5	mA
Operating Temperature Range ⁴	T _A	-40	125	°C
Storage Temperature Range	T _S	-65	135	°C
Magnetic Field ⁵	H		None	Oe

Notes:

- Differential = Operate Point – Release Point
- Minimum Release Point for AD8xx-xx to AD9xx-xx = 5 Oe.
- Output current must be limited by a series resistor. Exceeding absolute maximum continuous output current ratings will result in damage to the part.
- Thermal power dissipation for the packages used by NVE is 240°C/Watt for the SOIC8 package, and 320°C/Watt for the MSOP8 and packages. See the Figure on Ambient Temperature vs. Supply Voltage for derating information. Heat sinking the parts by attaching them to a PCB improves temperature performance.
- There is no maximum magnetic field that will cause damage to the device.
- If V_{CC}>6.6V, V_{REG}=5.8V. If V_{CC}<6.6V, V_{REG}= V_{CC} -0.9V.

ADH0xx-xx

Features:

- ⇒ Precision Low Field Magnetic Operate Point
- ⇒ Excellent Temperature and Voltage Performance
- ⇒ Digital Output
- ⇒ Frequency Response 0 to 250KHz
- ⇒ Small, Low Profile Surface Mount Packages

Applications:

- ⇒ Low Field Digital Position Sensing
- ⇒ Pneumatic Cylinder Position Sensing
- ⇒ Speed Sensing

Description:

The NVE ADH0xx Series GMR Switch uses NVE’s high sensitivity, high temperature GMR material to provide a very low magnetic field operate point. It offers the same precision operate points over all temperature and input voltage conditions as our other GMR Switch products. It is available in standard form as the NVE ADH025-00 with a magnetic trigger field of 10 Gauss, a current sinking output, and a cross axis configuration. Custom versions with trigger fields from 6 to 40 Gauss, and different output options and sensitivity directions could be manufactured for specific customer requirements; please contact NVE for details.

Note: Functional Block Diagram for the NVE ADH0xx-xx Series sensors is the same as for the NVE AD0xx-xx sensors.

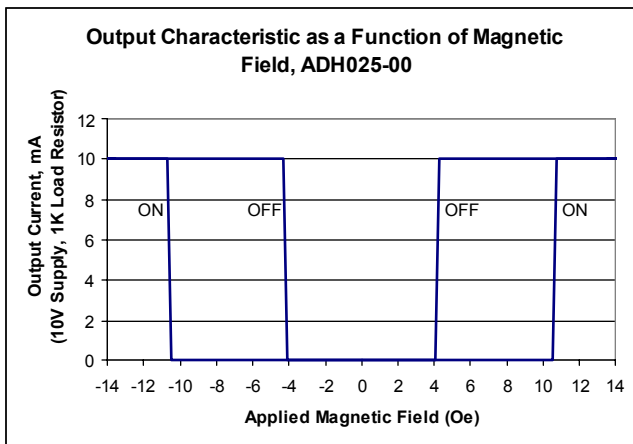

Magnetic Characteristics, NVE ADH025-00:

Typical Operate Point	Minimum Operate Point	Maximum Operate Point	Minimum Differential ¹	Maximum Differential ¹
10	8	12	3.5	10

Note: All Values in Oersteds (Oe); 1 Oe = 1 Gauss in Air

Electrical Specifications, NVE ADH0xx-xx:

Parameter	Symbol	Min	Max	Units	Test Condition
Supply Voltage ⁴	V _{CC}	4.5	30	V	Operating
Supply Current, Single Output	I _{CC}	3.0	6.0	mA	Output Off, V _{CC} =12V
Current Sinking Output ³	I _o	0	20	mA ³	Operating
Output Leakage Current	I _{LEAK}		10	μA	Output Off, V _{CC} =12V
Sinking Output Saturation Voltage	V _{OL}		0.4	V	Output On, I _{oL} =20mA

Absolute Maximum Ratings:

Parameter	Symbol	Min	Max	Units
Supply Voltage	V _{CC}		33	V
Reverse Battery Voltage	V _{RBP}		-33	V
Current Sinking Output Off Voltage			33	V
Current Sourcing Output Off Voltage			0	V
Current Sinking Reverse Output Voltage			-0.5	V
Current Sourcing Reverse Output Voltage			-0.5	V
Continuous Output Current	I _o		24	mA
Operating Temperature Range ⁴	T _A	-40	125	°C
Storage Temperature Range	T _S	-65	150	°C
Magnetic Field ⁵	H		None	Oe

Notes:

- Differential = Operate Point – Release Point
- Minimum Release Point for ADH0xx-xx = 2.0 Oe.
- Output current must be limited by a series resistor. Exceeding absolute maximum continuous output current ratings will result in damage to the part. See the figure in the GMR Switch Product Selection Guide for an output current derating curve.
- Thermal power dissipation for the packages used by NVE is 240°C/Watt for the SOIC8 package, and 320°C/Watt for the MSOP8 and TDFN6 packages. See the Figure on Ambient Temperature vs. Supply Voltage for derating information. Heat sinking the parts by attaching them to a PCB improves temperature performance.
- There is no maximum magnetic field that will cause damage to the device.



GT Sensors™

Precision Gear Tooth and Encoder Sensors

NVE's GT Sensor™ products are based on a Low Hysteresis GMR sensor material, and are designed for use in industrial speed applications where magnetic detection of gear teeth and magnetic encoder wheels is required.

GT Sensors with both analog and digital outputs are available. The analog parts feature the large signal and robust characteristics which NVE's GMR materials are known for (NVE's GMR sensors are not damaged by extremely large magnetic fields). The sensor elements themselves are designed to provide usable output with even the smallest gear teeth. Single and double output versions are available; the second output is phase shifted with respect to the first, to provide quadrature for determining direction.

The digital sensors take advantage of the high performance characteristics of GMR sensors to provide a 50% duty cycle output with a wide tolerance in airgap and temperature variations.

GT Sensors are available in low profile MSOP8, TDFN SO8, and TDFN6 packages, in order to fit into the tightest possible spaces. An evaluation kit is available, containing a selection of sensors, magnets, and PCBs, so that the user can test the parts in their application.

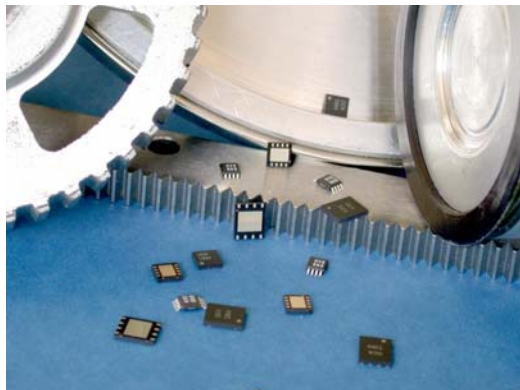

ABL Sensors

Single/Double Bridge Gear Tooth And Encoder Sensors

Features:

- ⇒ Large Airgap
- ⇒ Direct Analog Output
- ⇒ DC (Zero Speed) Operation
- ⇒ Sine / Cosine Outputs
- ⇒ Precise Spacing and Phase Shifting Between Sensor Elements
- ⇒ Excellent Temperature and Voltage Performance
- ⇒ Small, Low Profile Surface Mount Packages

Applications:

- ⇒ Linear and Angular Speed Sensing
- ⇒ Linear and Angular Position Sensing
- ⇒ Direction Detection

Description:

The ABL Series GT Sensors are differential sensor elements that provide an analog sinusoidal output signal when used with a bias magnet and gear tooth or a magnetic encoder. These chips use NVE's proprietary GMR sensor elements, featuring an extremely large output signal from the raw sensor element, which is stable over the rated temperature and voltage range. As a result, ABL Series GT Sensors feature excellent airgap performance and an extremely stable operating envelope, as well as the robust reliability characteristics that NVE sensors are known for.

Three different standard spacings are available, for use with fine and coarse pitch encoders and gear teeth. Both single bridge and double bridge configurations are also available; double bridges are used to generate sine/cosine outputs. In addition to the standard spacings, NVE can provide custom spacings and multiple sensor elements tailored to the individual customer's application for a nominal design and tooling charge. Contact NVE for further details.

For digital output applications, these sensors can be used with NVE's DD001-12 signal processing IC, which converts their output into a 50% duty cycle modulated current signal. This IC allows placement of the ABL sensor in a very small housing, with wires running from the sensor to the signal processing IC in a remote location. In this fashion ABL series sensors can be used in M8 and smaller housings.

Specifications:

Property	Min	Typ	Max	Unit
Single Bridge Resistance	4K	5K	7K	Ohms
Input Voltage	<1 ¹		30 ¹	Volts
Operating Temperature Range	-50		+170	°C
Offset Voltage	-4		+4	mV/V
Linear Range	+/-5		+/-100	Oe
Linearity of Output	98			% ²
Hysteresis			2	% ²
Saturation of GMR Sensor Elements	-180		+180	Oe ³
Single Resistor Sensitivity		.04		%ΔR/Oe ⁴
Max Output		80		mV/V
Temperature Coefficient of Resistance		+0.3		%/°C
ESD		400		V ⁵

Notes:

1. ABL Series sensors have a purely ratiometric output. They will operate with input voltages of 0.1V or lower. The output signal will scale proportionally with the input voltage. Maximum voltage will be limited by the power dissipation allowable in the package and user installation. See the package section for more details.
2. Linearity and Hysteresis measured across linear operating range, unipolar operation.
3. Application of a magnetic field in excess of this value will saturate the GMR sensor elements, and no further output will be obtained. No damage occurs to the sensor elements when saturated; *NVE GMR sensors will not be damaged by any large magnetic field.*
4. Percent change in resistance with application of 1 Oersted of magnetic field; corresponds to an 8% change in resistance with 200 Oersteds of applied magnetic field (1 Oersted = 1 Gauss in air, or 0.1 milli-Tesla).
5. Pin to pin voltage, Human Body Model for ESD

IC Drawings:

ABL004 Sensor Element Size and Spacing

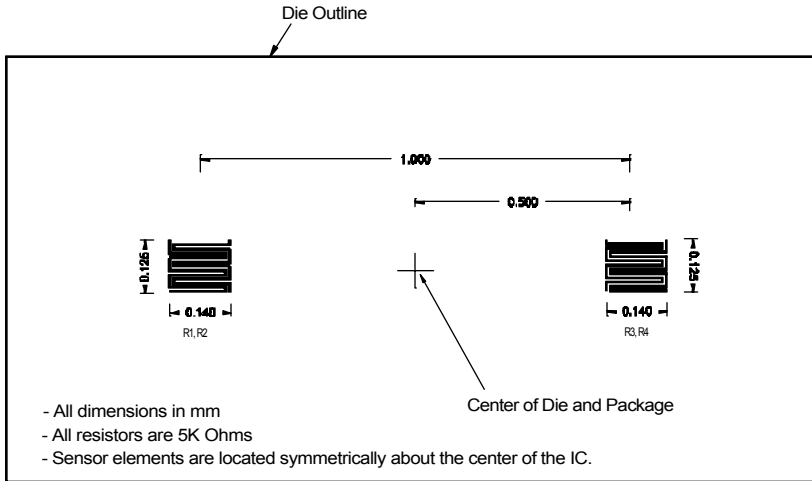

ABL005 Sensor Element Size and Spacing

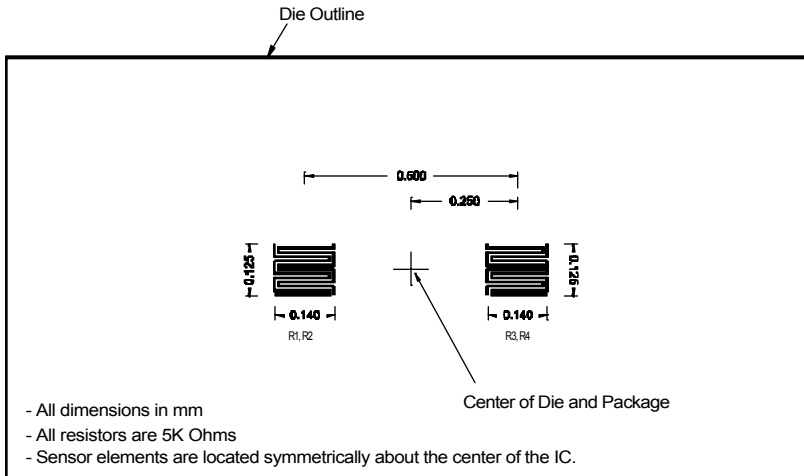

Note: ABL006 Sensor Element Size and Spacing Not Shown

ABL014 Sensor Element Size and Spacing

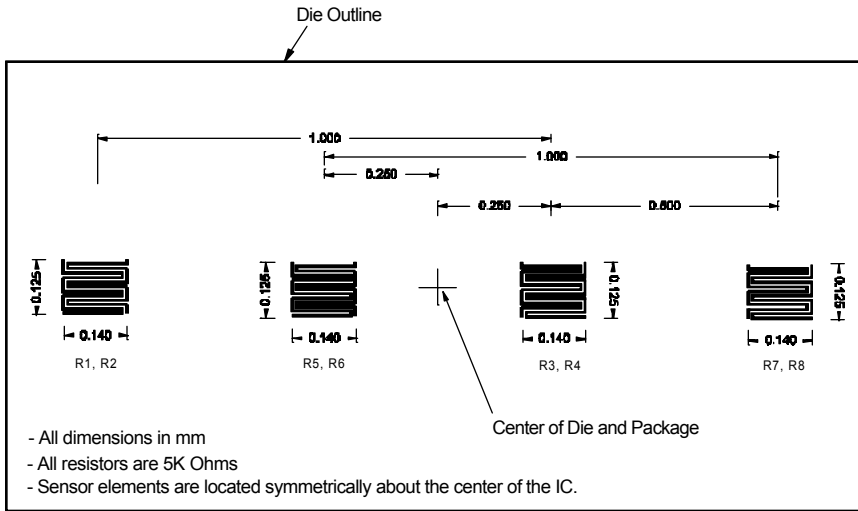

ABL015 Sensor Element Size and Spacing

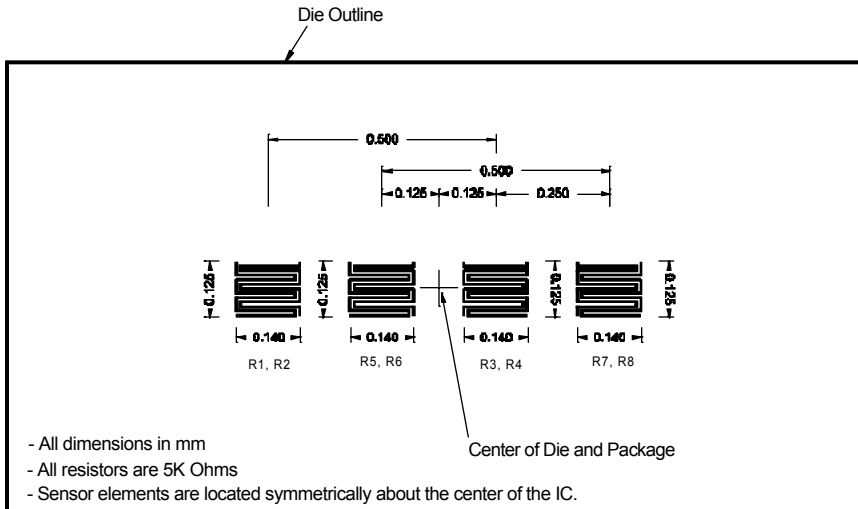

Note: ABL016 Sensor Element Size and Spacing Not Shown

Schematics:

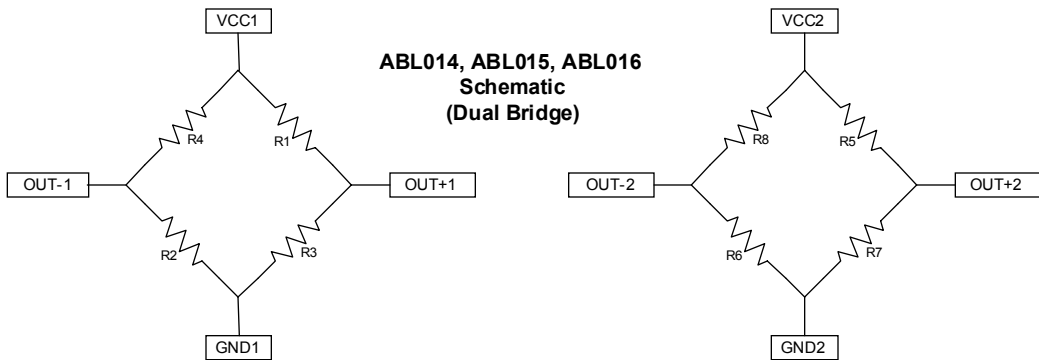
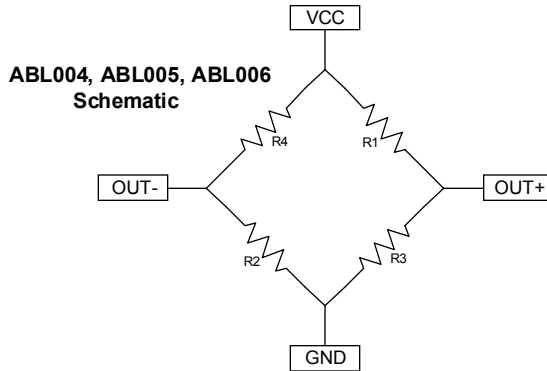

Part Numbers and Configurations:

Part Number	Single or Dual Bridge	Element Spacing (Microns)	Phase Shift Between Bridges (Microns)	Package Marking
ABL004-00	Single	1000	NA	FDB
ABL005-00	Single	500	NA	FDC
ABL006-00	Single	300	NA	FDL
ABL014-00	Dual	1000	500	FDD
ABL015-00	Dual	500	250	FDH
ABL016-00	Dual	300	150	FDM
ABL004-10	Single	1000	NA	FDG
ABL005-10	Single	500	NA	FDH
ABL006-10	Single	300	NA	FDN
ABL014-10	Dual	1000	500	FDJ
ABL015-10	Dual	500	250	FDK
ABL016-10	Dual	300	150	FDP

Packages:

The ABL series parts are available in MSOP8 and TDFN6 packages. Please see the package drawing section in the Appendix for dimensions. Please note that for dual differential sensors in the TDFN package, the power and ground connections for both bridges are common.

Pin Configuration:

MSOP8 Package

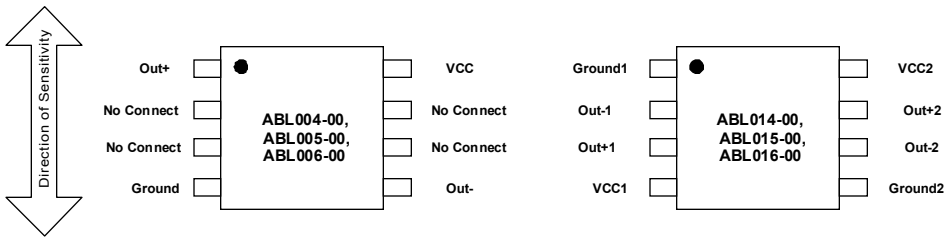

TDFN6 Package

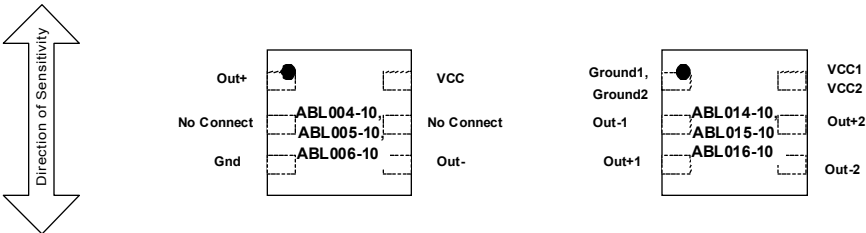

AKL Sensors

Digital Output Gear Tooth And Encoder Sensors

Features:

- ⇒ Large Airgap
- ⇒ 50% Duty Cycle
- ⇒ DC (Zero Speed) Operation
- ⇒ Precise Spacing Between Sensor Elements
- ⇒ Excellent Temperature and Voltage Performance
- ⇒ Small, Low Profile Surface Mount Package

Applications:

- ⇒ Anti-lock Brake System Sensors
- ⇒ Transmission Speed Sensors
- ⇒ Industrial Linear and Angular Speed Sensing
- ⇒ Linear and Angular Position Sensing

Description:

NVE offers these products specifically for use as sensors for gear tooth wheels or magnetic encoders with a digital output signal. The pulse output from the sensor corresponds with the gear teeth passing in front of it. When a gear tooth or magnetic pole is in front of the sensor, the sensor's output goes high; when the gear tooth or magnetic pole moves away, the output returns to low. This repeats at every tooth/pole, resulting in a pulse train output that provides speed information from the gear or encoder. Three part numbers are currently available: the AKL001-12 is designed for gear teeth or encoders with a pitch of 2.5 to 6mm, the AKL002-12 for a pitch of 1 to 2.5mm, and the AKL003-12 for a pitch of 0.6 to 1.5mm.

In order to minimize the number of wires leading to the sensor, the part is configured as a two wire device. The two output states are indicated with a change of current through the part. Therefore, when the part is in the digital low state, current is about 3mA. When the part is in the digital high state, the current increases to about 10mA. If necessary, the 2-wire output of the AKL series parts can be easily converted to a 3-wire current sinking output with the circuit shown in the GT Sensor applications section.

The parts are rated for the full automotive and industrial temperature range, -40°C to +150°C. They feature reverse battery protection, and have an operational voltage range of 4.5V to 48V. They operate from DC to 10 KHz. The parts are available in low profile, surface mount TDFN SO8 packages.

Specifications:

Property	Min	Typ	Max	Unit
Input Voltage	4.5		48	Volts ¹
Supply Current in Off State (Input Voltage=12V)	3.2	4.0	4.8	mA ²
Supply Current in On State (Input Voltage=12V)	7.0	8.0	9.0	mA ²
Output Duty Cycle	40	50	60	%
Operating Temperature Range	-40		+150	°C
AKL001-12 Airgap, Over Full Temperature and Voltage Range ³	1.0		3.5	mm
AKL002-12 Airgap, Over Full Temperature and Voltage Range ³	1.0		2.5	mm
Frequency of Operation	0		10K	Hz
ESD		2000		V ³

Absolute Maximum Ratings	
Parameter	Limit
Supply Voltage	60V
Reverse Battery Voltage	-60V
Continuous Output Current	16mA
Junction Temperature Range	-40°C to +175°C
Storage Temperature Range	-65°C to +200°C

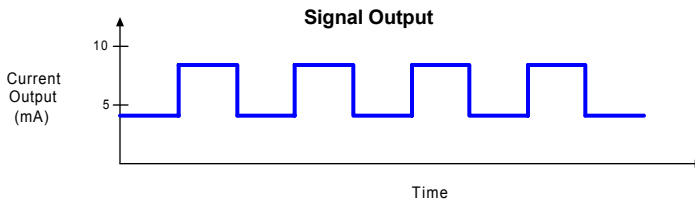

Notes:

1. The supply voltage must appear across the power and ground terminals of the part. Any additional voltage drop due to the presence of a series resistor is not included in this specification.
2. Supply currents can be factory programmed to different levels, for example 3mA and 6mA, or 7mA and 14mA; contact NVE for details.
3. Pin to pin voltage, Human Body Model for ESD
4. Airgap measured with standard ferrous gear tooth, contact NVE for details.

IC Drawings:

The AKL Series products use the ABL sensor elements described earlier in this section. The AKL001-12 part uses the ABL004 sensor element, the AKL002-12 uses the ABL005 sensor element, and the AKL003-12 uses the ABL006 sensor element. Please see the IC drawings in the ABL series section for more information.

Part Numbers and Configurations:

Part Number	Single or Dual Bridge	Element Spacing (Microns)	Marking
AKL001-12	Single	1000	Part Number
AKL002-12	Single	500	Part Number
AKL003-12	Single	300	Part Number

Schematic:

A block diagram of the AKL series parts is shown below:

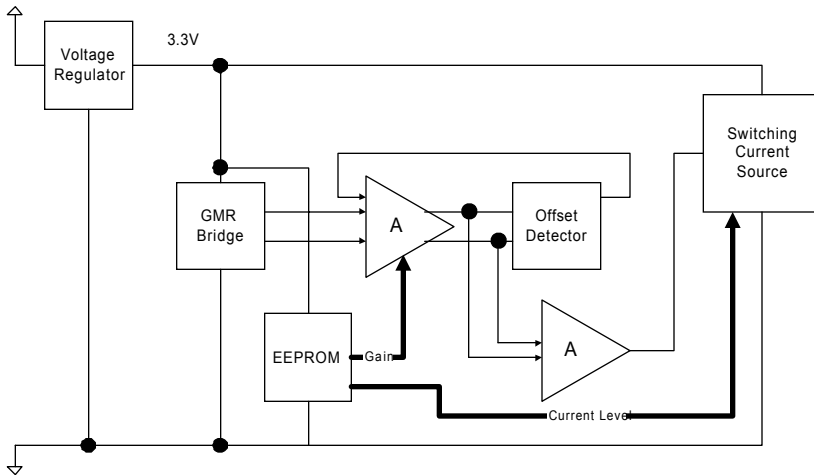

Packages:

The AKL series parts are available in the TDFN8 SO8 package. Please see the package drawing section in the Appendix for dimensions.

Pin Configuration:

TDFN8-SO8 Package

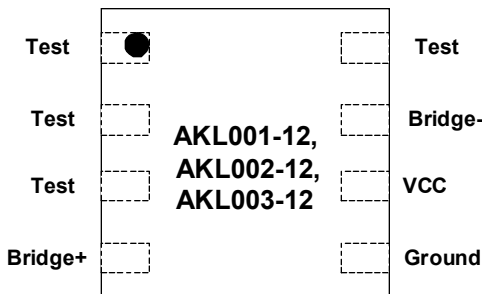

Note: Bridge + and Bridge - are provided for analysis purposes only. NVE does not recommend connecting these pins in a production product, for ESD and loading reasons. Also, all pins labeled 'Test' must be floating, *i.e.* not connected to each other, or any other circuit node.

Application Notes for GT Sensors

General Theory of Operation of Differential Sensors (Gradiometers)

Differential sensors, or gradiometers, provide an output signal by sensing the gradient of the magnetic field across the sensor IC. For example, a typical GMR sensor of this type will have four resistive sensor elements on the IC, two on the left side of the IC, and two on the right. These resistive sensor elements will be wired together in a Wheatstone bridge configuration. When a magnetic field approaches the sensor IC from the right, the right two resistive sensor elements will decrease in resistance before the elements on the left. This leads to an imbalance condition in the bridge, providing a signal output from the bridge terminals.

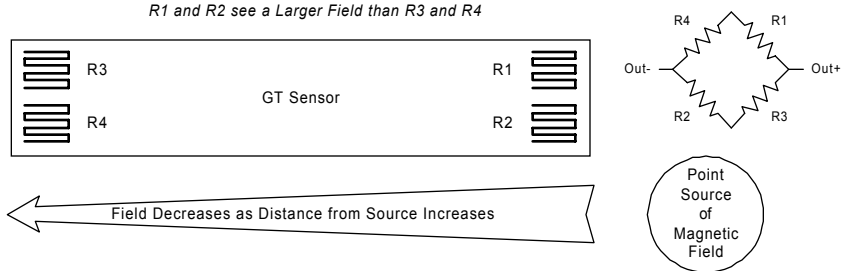

Note that if a uniform magnetic field is applied to the sensor IC, all the resistive sensor elements will change at the same time and the same amount, thus leading to no signal output from the bridge terminals. Therefore, a differential sensor cannot be used as a magnetometer, or an absolute field detector; it must be used to detect the presence of a magnetic gradient field.

Gradient fields are present at the edge of magnetic encoders and magnetically biased gear teeth. As a result, differential sensor elements are ideally suited for speed and position detection in these applications.

GT Sensor Operation with Permanent Magnet Bias

Magnetic encoders generate their own magnetic field, but a gear tooth wheel does not, so if a differential sensor is to be used to detect gear teeth, a permanent magnet of some sort must be used to generate a magnetic bias field. The differential magnetic sensor will then be used to detect variations in the field of the permanent magnet as the gear tooth passes by in close proximity.

Application Notes for GT Sensors

The following series of drawings shows a biased GT Sensor. The drawings show how the magnetic field generated by the bias magnet is influenced by the moving gear tooth, and what the output signal from the sensor looks like at four equally spaced positions, from one gear tooth to the next:

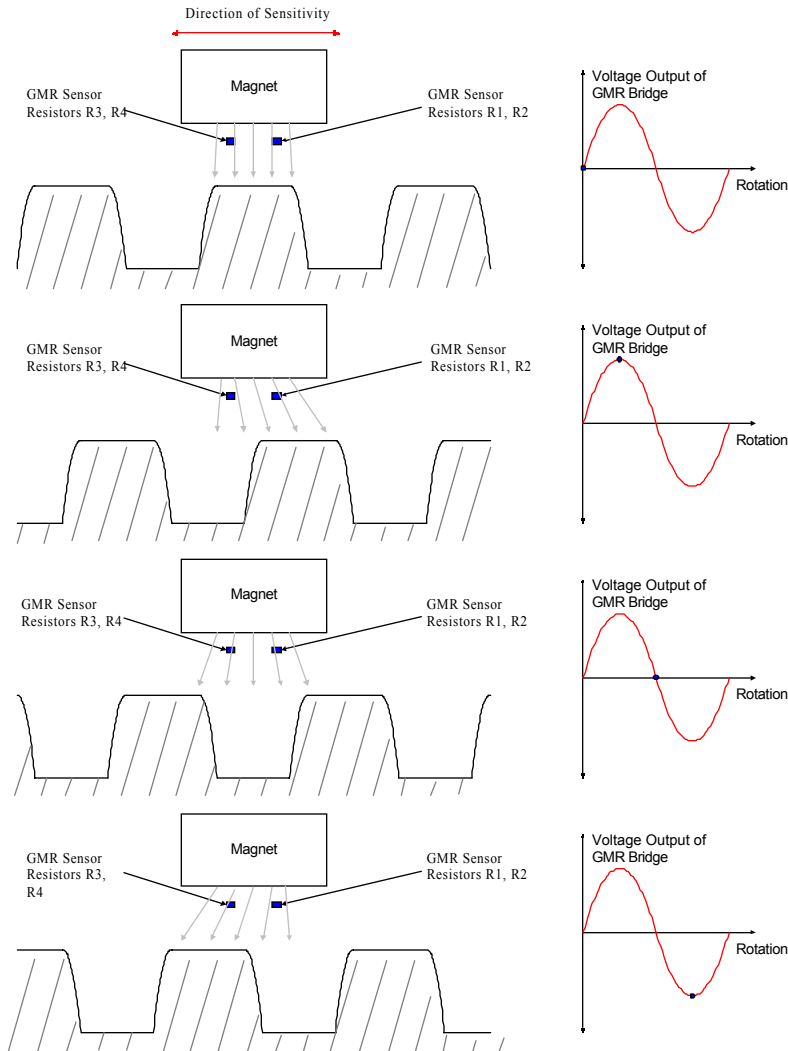

Application Notes for GT Sensors

Despite the simple nature of the preceding drawings, magnetically biasing a gear tooth for a production product can be a complex and difficult task. Typically, the position of the sensor relative to the magnet is fixed, but there is a variation in the airgap between the sensor and the target (gear tooth). This arrangement leads to various magnetic conditions that can cause instability in the sensor output. For example, tolerances on the placement of the magnet relative to the sensor are not perfect, and any slight variation in the placement of the magnet can lead to offset problems; see the drawing below:

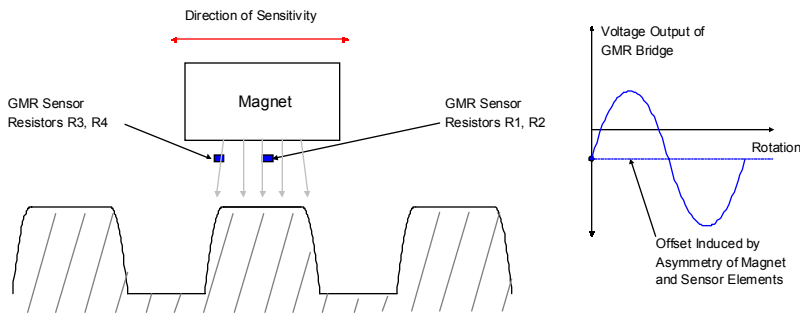

Generally the magnet is glued in place; this can lead to tilting of the magnet with respect to the sensor, introducing more variations in the field at the sensor, and more offset problems, not to mention potential glue joint problems. Further, the composition of most inexpensive magnets is not particularly uniform, and many have cracks or other mechanical imperfections on the surface, or internally, that will lead to a non-uniform magnetic field. Most permanent magnets have a temperature coefficient, and some can lose up to 50% of their strength from room temperature to 125°C. The following drawing shows the effects of temperature, added onto an imperfect bias. As can be seen, the offset of the sensor varies with temperature.

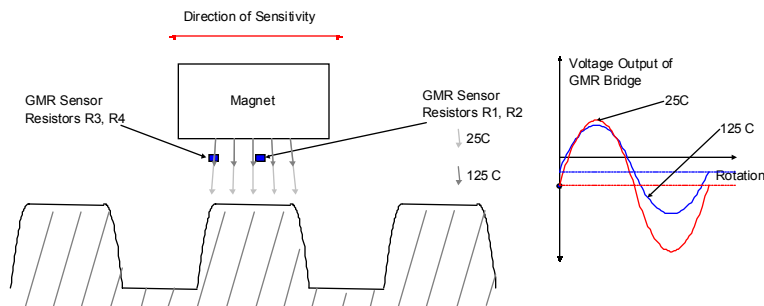

Finally, as the airgap changes, the magnetic field at the sensor also changes. So, the magnetic field at the sensor will vary from one installation to the next, and if the gear has

runout, wobble, or expands with temperature, the output signal and offset of the sensor element will vary.

As a solution to these potential problems, NVE's AKL series GT Sensors offer internal signal processing which compensates for temperature variation, sensor output variation, and magnet/target variation. This results in a stable digital output signal with wide tolerance for magnet placement and quality. For analog applications, NVE offers the following guidelines for biasing GT Sensors with permanent magnets:

1. NVE recommends about 1.5mm distance from the back of the sensor to the face of the magnet, in order to keep the flux lines at the sensor element "flexible", and able to follow the gear teeth with relative freedom. This distance can be achieved by putting the sensor on one side of a circuit board, and the magnet on the other.
2. To fix the position of the magnet on the circuit board more precisely, the board can be made thicker, and a pocket can be machined into it to hold the magnet. This service is readily available from most circuit board manufacturers.
3. Various high temperature epoxies can be used to glue the magnet in position; NVE recommends 3M products for this purpose.
4. If zero speed operation is not required, AC coupling the sensor to any amplifier circuitry will remove the offset induced in the sensor by the magnet.
5. If zero speed operation is required, some method of zeroing the magnet-induced offset voltage from the sensor will be required for maximum airgap performance. NVE's AKL series sensors have this feature built in, and NVE's DD001-12 signal conditioning IC also includes this feature.
6. GT Sensor ICs are centered in the plastic package, so placement of the permanent magnet should be symmetrical with the package.
7. Ceramic 8 magnets are a popular choice in this application, and provide good field characteristics, and low cost. However, C8 magnets lose substantial magnetic strength at higher temperatures. For analog output applications where a consistent signal size over temperature is desirable, use of an Alnico 8 magnet (the most temperature stable magnet) is recommended. Samarium cobalt magnets and Neodymium-Iron-Boron magnets are not recommended, because they are so strong that they tend to saturate the GMR sensor element.

GT Sensor Operation with Magnetic Encoders

Magnetic encoders generate their own magnetic field; as a result, they are much easier to work with than gear tooth wheels. One reason is because no bias magnet is required for the sensor. Also, a magnetic encoder has alternating north and south magnetic poles on its face. Therefore the magnetic field is generated by the moving body, and sensor offset problems are greatly reduced. The following drawing shows a GT Sensor response to a magnetic encoder:

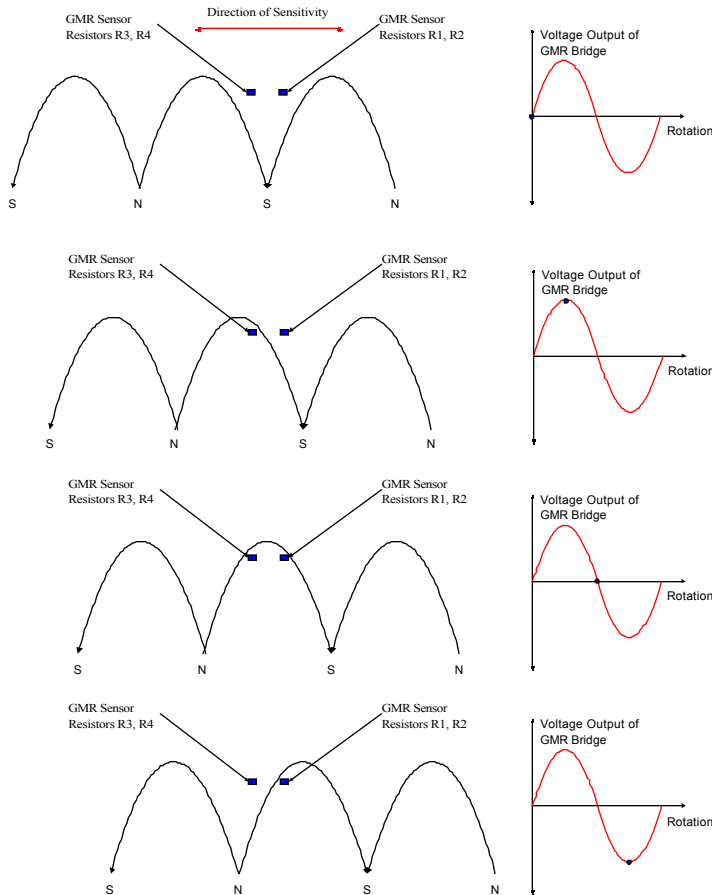

Note that in this case, as long as the sensor is positioned symmetrically with the encoder, offset is minimized. Also note that the GT Sensor provides one full sine wave output for each magnetic pole. This is double the frequency of a Hall effect sensor, which will

provide one full sine wave output for each north-south pole pair. As a result, replacing a Hall sensor with a GT sensor will double the resolution of the output signal.

NVE offers the following guidelines for using GT Sensors in magnetic encoder applications:

1. Position the sensor as symmetrically as possible with the encoder to minimize offset problems.
2. AC couple the sensor to an amplifier to eliminate any offset issues if zero speed operation is not required.
3. If zero speed operation is required, NVE's AKL series and DD series parts automatically compensate for offset variations, and provide a digital output signal.

Application Circuits

Signal processing circuitry for analog output sensors, such as NVE's ABL series products, varies widely in cost, complexity, and capability. Depending on user requirements, a single op amp design may be sufficient. For low signal level detection, a low noise instrumentation amp may be desirable. For complete control of all parameters, use of a complete signal processing IC which can tailor gain, offset calibration, and temperature compensation may be required. Please see NVE's Engineering and Application Notes bulletin for further details on the various approaches that are available.

For digital output applications, NVE's AKL series and DD series products provide the most cost effective approach. Both of these products provide 2 wire, or current modulated, output signals. For many applications, an open collector or digital voltage

Application Notes for GT Sensors

output signal is desirable. The following two circuits show how to convert a 2-wire current modulated signal into an open collector or digital voltage output signal:

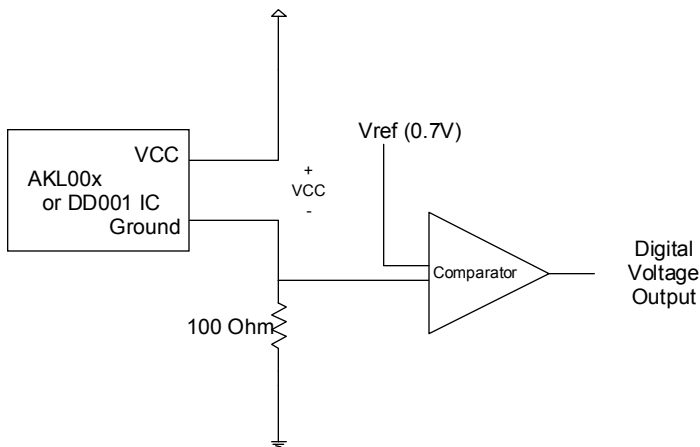
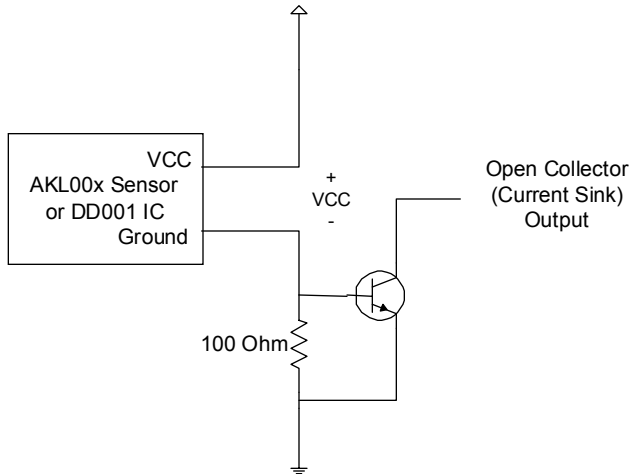

Circuit Board Sensor Products

AG20x-07 Cylinder Position Sensors PCB Assemblies for Pneumatic Cylinder Applications

Features:

- ⇒ Precision Magnetic Operate Point
- ⇒ 3 Wire Current Source or Current Sink Output
- ⇒ Wide Operating Temperature Range
- ⇒ Short Circuit, Transient, and ESD Protected
- ⇒ Conforms to EN 60947-5-2 Standards for Switchgear

Applications:

- ⇒ Pneumatic Cylinder Position Sensing
- ⇒ General Magnet Position Sensing

Description:

The AG202-07 and AG203-07 PCB assemblies are small, sensitive magnetic sensors for use in pneumatic cylinder position sensing and other position sensing applications. They are designed to be potted or injection molded by the customer to make a complete magnetic sensor assembly, with a cable attached and enclosed in a plastic housing. The PCB assemblies include an NVE AD8xx or AD9xx magnetic sensor, plus surrounding signal processing and filtering components. These parts provide a precise, temperature stable magnetic operate point, and will source or sink up to 200mA of output current. They also feature reverse battery protection and short circuit protection, as well as immunity to transients as specified in US and European standards, such as EN60947-5-2.

The assemblies have a yellow LED to indicate the presence of the magnetic field, and are sized to fit into small package housings. Output from the parts are open collector PNP (AG203-07) or NPN (AG202-07) transistors, in current sourcing or current sinking configurations. The end customer is required to limit the output current to the desirable level, from 5mA to 200mA, with an external load resistor.

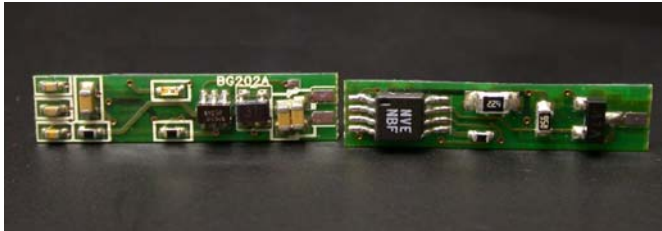

General Electrical Characteristics				
Property	Min	Typical	Max	Unit
Input Voltage Range	4.5		30	V
Temperature Range ²	-20		85	°C
Magnetic Operate Point ¹	21	28	34	Oe
Magnetic Release Point ¹	5		14	Oe
Reverse Battery Protection			-30	V
LED		Yellow		
$V_{CC} - V_{OH}$ (Maximum Output Voltage Drop Across Part)			2	V
Output Current	5		200	mA
Supply Current	2.5		4.5	mA
Dimensions:		19.5mm		Length
		4.2 mm		Width
		2.9 mm		Height

Notes:

1. See AD824-00 and AD924-00 data in GMR Switch section of this catalog.
2. These parts are assembled with high temperature solder; overmolding at temperatures up to 210C for 10 seconds is approved.

Functional Block Diagram

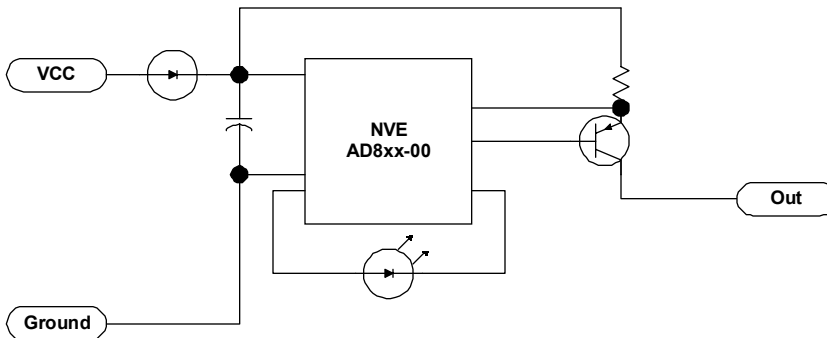

Wiring Diagram

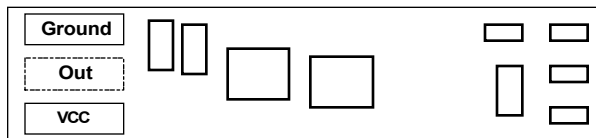

AG Series Currency Detection Sensors

Sensor Arrays for Currency / Magnetic Media Detection

Features:

- ⇒ Arrays of Sensor Elements for Broad Area Coverage
- ⇒ No Contact with Media Required
- ⇒ Capable of Detecting Very Low Magnetic Fields

Applications:

- ⇒ Currency Detection and Validation
- ⇒ Other Magnetic Media Applications (Checks, Credit Cards, etc.)
- ⇒ General Area Sensing for Low Magnetic Fields

Description:

These products are custom built PCB assemblies for customer specific applications. They typically contain 20 to 60 analog GMR sensor elements, most often the AA002, AAH002, or AAL002 sensors. These sensors are mounted on a PCB, most often using Chip-On-Board (COB) assembly techniques, so that the sensor elements can be placed very close together. In addition, a coil on the PCB is provided on many of these designs, so that a current can be fed through the coil to provide a magnetic bias field at the sensors.

In a typical currency detection application, this PCB assembly is positioned so that the currency rides by at a distance of about 1 mm on some kind of feed mechanism. The bank note is typically magnetized before it reaches the sensor array, with a permanent magnet. The residual magnetization in the magnetic ink or stripe of the currency is detected by the sensor array. This information is then analyzed to determine if the currency is genuine. See the figure below:

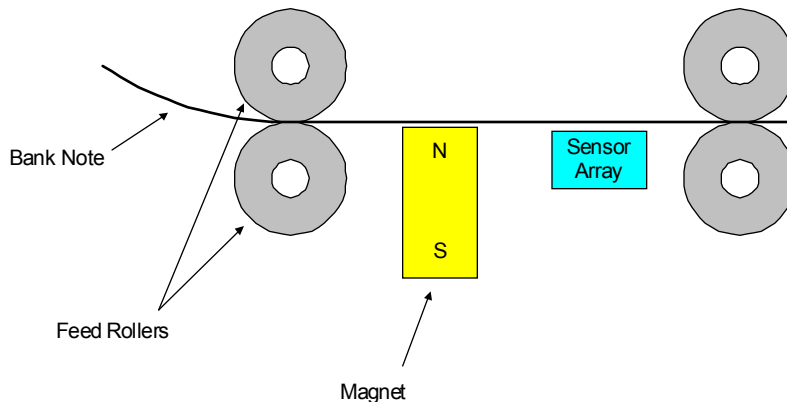

Since every application is different in terms of circuit board and sensor configuration, NVE does not offer a standard product for this application. However, NVE is prepared to rapidly prototype these assemblies for customer evaluation at a nominal cost. Please contact NVE for details.



Peripheral Integrated Circuits

Complimentary Products for NVE's GMR Sensors

In addition to GMR Sensor products, NVE has begun designing and manufacturing accessory products for our sensors. These products are designed to be used with NVE's sensors, or in some cases as stand-alone parts, to provide higher level signal processing capabilities coupled with the robust performance characteristics that NVE products are known for.

DB Series Power Switch ICs – In many industrial control applications, a digital current output of up to 200mA is required. NVE's DB Series parts are designed to meet these requirements. They feature transient protection to meet rigid EMC and ESD standards, thermal shutdown for temperature protection, reverse battery protection, a regulated voltage output, an on-chip LED driver, and short circuit protection of the current drive output transistor. The DB001-00 is designed specifically to work together with NVE's AD9xx-00 short circuit protected GMR switch, to create a very small IC combination suitable for use in miniature sensor assemblies. The DB002-02 is designed to take a generic digital input from any source, including inductive and photo sensors, and provide the digital current output.

DC Series Voltage Regulator ICs – These ICs are designed for use in high voltage, low current applications. They provide a wide input voltage range, up to 60V, and are available in 3.3V and 5.0V outputs. They feature reverse battery protection and excellent immunity to transients and noise, allowing for the reduction or elimination of filtering devices at the PCB level. They are available in the TDFN6 package, which features a small PCB footprint (2.5mm X 2.5mm), and an exposed lead frame on the back, for heat sinking to the PCB. DC series voltage regulators meet 42V automotive standards.

DD Series Signal Processing IC for Analog GT Sensors – The DD001-12 is designed to be interfaced with an NVE ABL series GT Sensor, to provide a digital output signal with excellent stability characteristics. It can be located away from the sensor, so that the ABL package (MSOP8 or TDFN6) can be placed in a small remote housing, resulting in the absolute minimum size sensor package. The DD001-12 can also be used with other sensing devices which feature a sinusoidal output, to provide the same stable current modulated signal that it provides for NVE's ABL series GT Sensors.

DB Series Power Switch ICs

Features:

- ⇒ Designed to Work Independently, or with AD9xx
- ⇒ High Current Output
- ⇒ Short Circuit, Reverse Battery, and Transient Protection
- ⇒ LED Driver
- ⇒ Excellent Temperature and Voltage Performance
- ⇒ Small, Low Profile Surface Mount Package

Applications:

- ⇒ Output Driver for Sensor Assemblies
- ⇒ Usable with Magnetic, Inductive, and Photo Sensors

Description:

The DB series signal processing ICs are designed to take a digital input from a sensor element, and provide a high current switched output corresponding with the sensor input. These parts function as the “front end” of a complete sensor assembly, and include protection against short circuits and high voltage transients from capacitive and inductive loads. The parts also feature thermal shutdown circuitry and reverse battery protection. They provide a regulated output voltage for the sensor and other components in the assembly, and an LED driver to indicate an “ON” condition.

Two different part numbers are offered, the DB001-00 and the DB002-02. The DB001-00 is designed to work with NVE’s AD9xx short circuit protected GMR switch products. Together, these two ICs form the bulk of the signal processing required for pneumatic cylinder position sensing electronics. Using these two ICs, the end user only requires a few capacitors and an LED in order to implement the complete sensor assembly circuit. In addition, both the AD9xx part and the DB001-00 part come in MSOP8 packages, so that the customer can implement the complete design on an extremely small PCB.

The DB002-02 uses the larger SOIC8 package, and is designed to work with NVE’s AD1xx GMR Switch products, as well as any other current sourcing or CMOS/TTL digital output sensor element, such as an inductive sensor or a photo sensor. For size critical applications, both the DB001-00 and DB002-02 are available in die form.

Part Numbers and Configurations:

Part Number	Input	Die Size (mm)	Package	Marking
DB001-00	Current Sinking from AD9xx-00	1.48 X 2.25	MSOP8	FFD
DB002-02	Any Current Sourcing or CMOS/TTL Compatible Digital Output Device	1.48 X 3.00	SOIC8	Part Number

Schematic:

A block representation of the DB001-00 series parts is shown below:

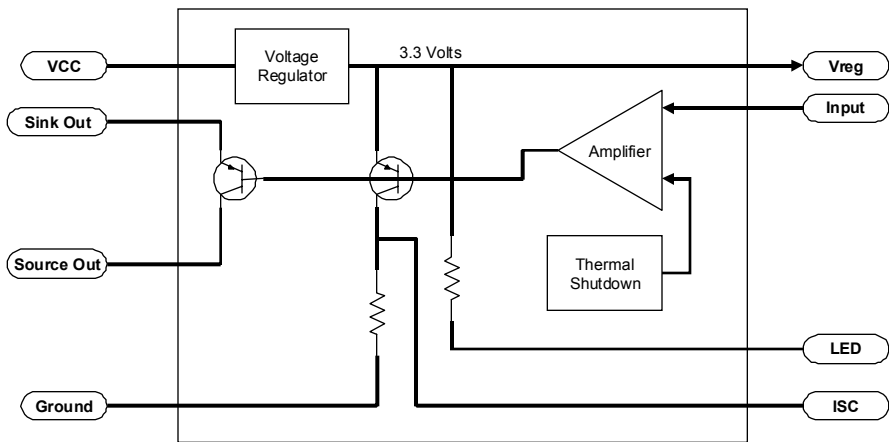

A block representation of the DB002-02 series parts is shown below:

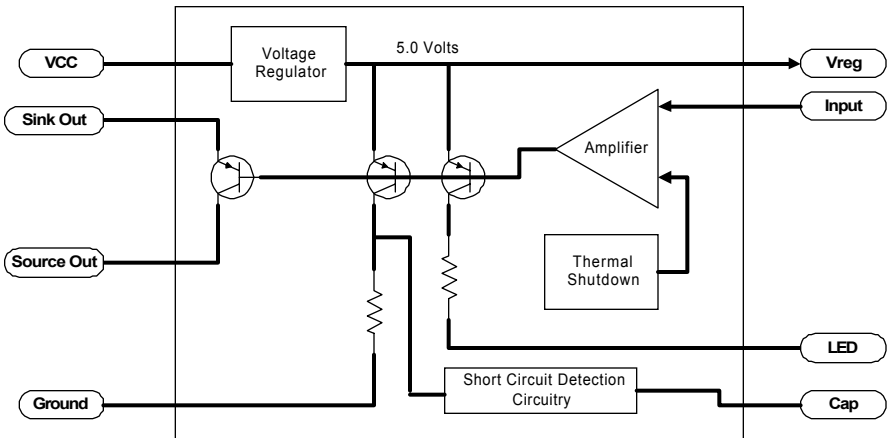

Packages:

Please see the package drawing section in the Appendix for dimensions of the MSOP8 and SOIC8 packages.

Pin Configuration:

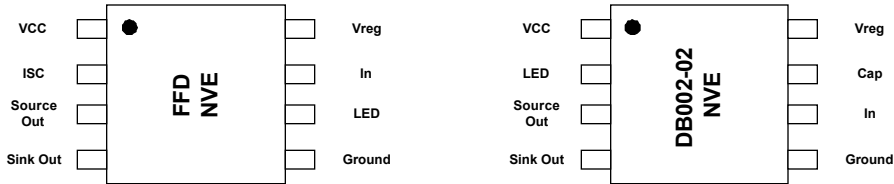

Application Circuits:

DB001-00 in Current Sourcing Output Configuration:

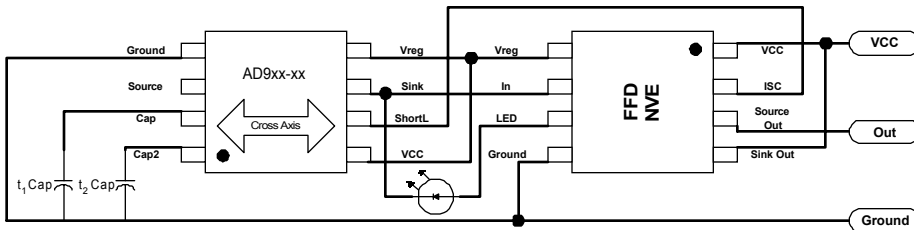

Note: For current sinking applications, connect Source Out pin to Ground, and use Sink Out pin as the output.

DB002-02 in Current Sourcing Output Configuration:

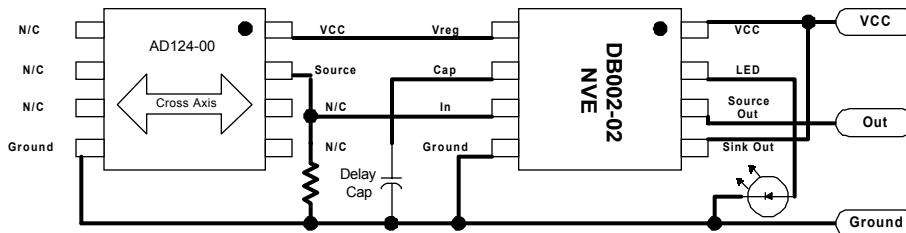

Note: For current sinking applications, connect Source Out pin to Ground, and use Sink Out pin as the output.

Electrical characteristics @-40°C to +125°C, unless otherwise noted

Parameter	Min	Typ	Max	Units
Input Voltage (DB001-00)	4.5		30	Volts
Vreg Voltage (DB001-00)	3.0	3.3	3.6	Volts
Input Voltage (DB002-02)	6.2		30	
Vreg Voltage (DB002-02)	4.5	5.0	5.5	Volts
Vreg Output Current			10	Milliamps
Switched Output Current			200	Milliamps
Bias Current (DB001-00)		1.0		Milliamps
Bias Current (DB002-02)		1.4		Milliamps
Bias Current Change when part is On (DB002-02)			+700	Microamps
LED Drive Current		3		Milliamps
Thermal Shutdown Temperature		175		°C
Sinking Input Current Required (DB001-00)		100		Microamps
Sourcing Input Current or CMOS/TTL Drive Current Required (DB002-02)		5		Microamps
Output Transistor Saturation Voltage	1.0	1.2	1.4	Volts

Absolute maximum ratings *	
Parameter	Limit
Input Voltage	36V
Reverse Battery Protection	-36V
Output Current	300mA
Junction Temperature Range, T _J	-40°C to +175°C
Storage Temperature Range	-65 °C to +200°C

*Stresses beyond those listed under “Absolute maximum ratings” may cause permanent damage to the device. These are stress ratings only, and functional operation of the device at these or any other conditions beyond those indicated under “Electrical characteristics” is not implied.

Notes:

1. This part has reverse battery protection to -36V
2. Due to package size, MSOP8 package contains 3-letter code to designate part type.

DC Series Voltage Regulators High Voltage, Low Power Voltage Regulators

Features:

- ⇒ Input Voltage to 48VDC (Max Rating 60VDC)
- ⇒ 5.0V and 3.3V Regulated Output
- ⇒ Reverse Battery Protection
- ⇒ Excellent Immunity to Transients and ESD
- ⇒ High Temperature Operation
- ⇒ Small, Low Profile Surface Mount Package

Applications:

- ⇒ Industrial Sensors and Controls
- ⇒ Automotive Sensors and Controls

Description:

The DC series voltage regulator ICs are designed to be used in harsh, noisy environments where immunity to large voltage transients and acceptance of high input voltages are required. These regulators protect the sensitive electronic components downstream, while providing a stable regulated supply voltage. They are rated for high temperature operation, up to +175C. The low profile small footprint package features an exposed die attach pad, for direct heat sinking to the circuit board.

Electrical characteristics @-40°C to +175°C, unless otherwise noted

Parameter	Min	Typ	Max	Units
Input Voltage (DC001-10)	4.5		48	Volts
Output Voltage (DC001-10)	3.0	3.3	3.6	Volts
Input Voltage (DC002-10)	6.2		48	Volts
Output Voltage (DC002-10)	4.5	5.0	5.5	Volts
Output Current			20	Milliamps
Bias Current at Zero Output Current			500	Microamps

Absolute maximum ratings *	
Parameter	Limit
Input Voltage	60V
Reverse Battery Voltage	-60V
Output Current	25mA
Junction Temperature Range, T _J	-40°C to +175°C
Storage Temperature Range	-65 °C to +200 °C

*Stresses beyond those listed under “Absolute maximum ratings” may cause permanent damage to the device. These are stress ratings only, and functional operation of the device at these or any other conditions beyond those indicated under “Electrical characteristics” is not implied.

Notes:

1. Power dissipation rating for TDFN6 package in free air is 320°C/Watt. Soldering the package to a PCB, including the die attach paddle, improves temperature performance substantially. The input voltage and output current are limited by thermal power dissipation at the package.
2. Due to package size, TDFN6 package contains 3-letter code to designate part type.

Part Numbers and Configurations:

Part Number	Regulated Output Voltage	Package	Marking
DC001-10	3.3V	TDFN6	FFB
DC002-10	5.0 V	TDFN6	FFC

Package:

Please see the package drawing section in the Appendix for dimensions of the TDFN6 package.

Pin Configuration:

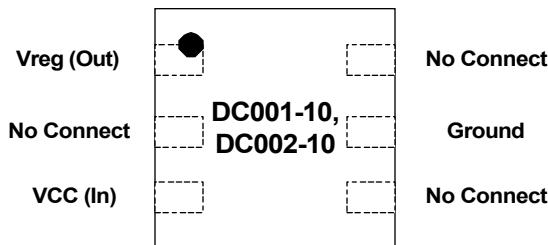

Note: The die attach pad is exposed on the back of this package. NVE recommends that it is connected to the ground pin and the PCB to improve temperature performance of the part.

DD Series Signal Processing ICs

For use with ABL Series Sensors

Features:

- ⇒ Converts Analog Sensor to Digital Operation
- ⇒ 2 Wire Output
- ⇒ 50% Duty Cycle
- ⇒ DC (Zero Speed) Operation
- ⇒ Excellent Temperature and Voltage Performance
- ⇒ Small, Low Profile Surface Mount Package

Applications:

- ⇒ Linear and Angular Speed Sensing
- ⇒ Linear and Angular Position Sensing
- ⇒ Direction Detection

Description:

The DD series signal processing IC is designed to take an analog, sinusoidal input signal such as that provided by NVE's ABL series sensors, and convert it to a two wire, current modulated digital output. Inputs as small as 2mV peak to peak can be provided to the IC, along with large signal offsets; the DD001-12 part will provide a 50% duty cycle digital output signal.

The DD001-12 part contains a voltage regulator circuit, programmable amplifier, offset detection and correction circuitry, and an EEPROM for setting gain and current levels. The voltage regulator output (3.3V) is used to power the external sensor element; it should be connected between Vreg and V-. Nominal current levels for the current modulated output are 3mA and 10mA. These can be factory programmed to different levels for specific customer requirements.

Using the DD series signal processing IC allows the user to put the sensor element, which can very small, in a remote location, and pipe the signals from the sensor to the DD001-12 for digitizing purposes. In addition, if two phase shifted sensor outputs are available (such as with the ABL014-00 and ABL015-00 sensors), two DD001-12 parts can be used to provide two phase shifted digital signals, for the purpose of detecting the direction of the gear tooth or encoder wheel.

The 2-wire output of the DD001-12 can be easily converted to a 3-wire current sinking output with the circuit shown in the GT Sensor applications section.

Specifications:

Property	Min	Typ	Max	Unit
Input Voltage	4.5		48	Volts ¹
Input Voltage Signal	2		200	mV ²
Input Current			10	μA
Supply Current – Off (Input Voltage=12V)	2.2	3.0	3.8	mA ³
Supply Current – On (Input Voltage=12V)	7.0	8.0	9.0	mA ³
Output Duty Cycle	40	50	60	%
Regulated Voltage Output	3.0	3.3	3.6	Volts
Current Supplied by Regulated Voltage Output			10	mA
Operating Temperature Range	-40		+125	°C
Frequency of Operation	0		10K	Hz
ESD		2000		V ⁴

Absolute Maximum Ratings	
Parameter	Limit
Supply Voltage	60V
Reverse Battery Voltage	-60V
Continuous Output Current	16mA
Junction Temperature Range	-40°C to +175°C
Storage Temperature Range	-65°C to +200°C

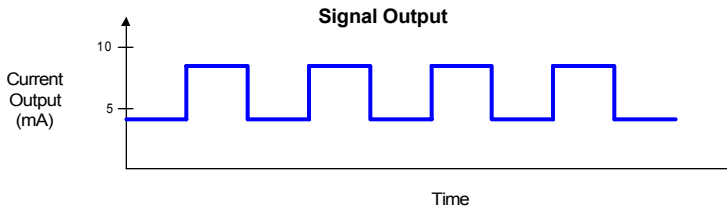

Notes:

1. The supply voltage must appear across the power and ground terminals of the part. Any additional voltage drop due to the presence of a series resistor is not included in this specification.
2. Input signal range can be adjusted by programming the amplifier gain to a specific value; contact NVE for details.
3. Supply currents can be factory programmed to different levels, for example 3 mA and 6 mA, or 7 mA and 14 mA; contact NVE for details.
4. Pin to pin voltage, Human Body Model for ESD.

Schematic:

A block representation of the DD series parts is shown below:

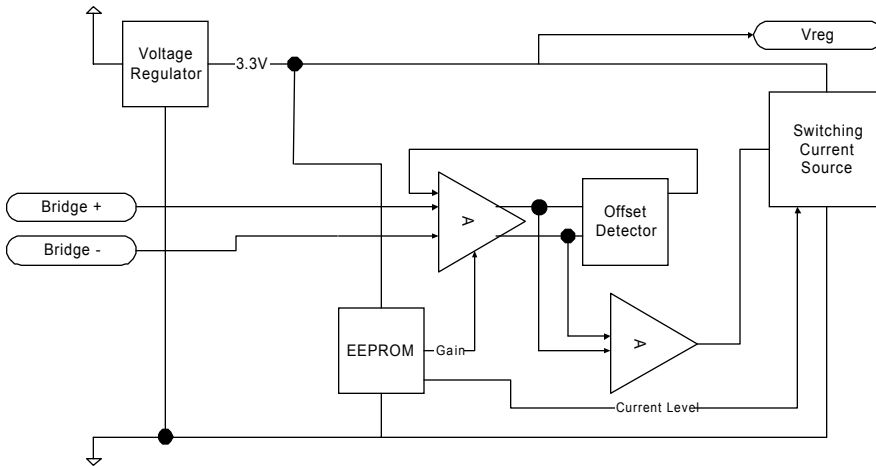

Packages:

The DD series parts are available in the TDFN SO8 package. Please see the package drawing section in this catalog for dimensions.

Pin Configuration:

TDFN-SO8 Package

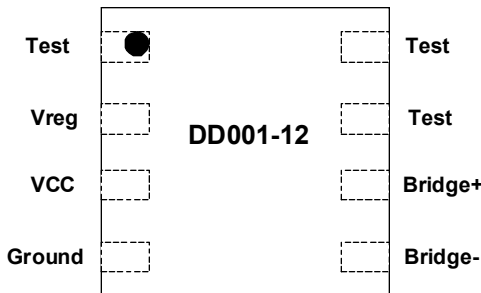

Note: Bridge + and Bridge – should be connected only to the sensor element outputs, for ESD and loading reasons. Vreg can supply up to 10mA at 3.3V (330 Ohm Load). Also, all pins labeled ‘Test’ must be floating, *i.e.* not connected to each other, or any other circuit node.

Evaluation Kits

In order for our customers to evaluate GMR sensors in their application, NVE makes available several evaluation kits, at nominal cost, so that customers can try the actual parts in their application. These kits are described below:

AG001-01 - Analog Sensor Evaluation Kit

This kit features several types of NVE's AA and AB series parts, a selection of permanent magnets for activation or bias purposes, and circuit boards to mount the parts for testing purposes. Also included is a copy of NVE's catalog and application notes on CD ROM.

AG003-01 - Current Sensor Evaluation Kit

This kit features a specially designed circuit board with traces running under the sensor elements. The customer can try different current levels to see the output from the sensor. Also included is a copy of NVE's catalog and application notes on CD ROM, and a copy of NVE's Current Calculator spreadsheet.

AG910-07, AG911-07 - GMR Switch Evaluation Kits

These kit includes several GMR Switch parts, with different magnetic operate points and different output options such as current sink and current source. In addition, magnets and circuit boards for mounting the parts in the application are included, along with a copy of NVE's catalog and application notes on CD ROM. In the AG910-07 kit, a socket for easy testing of the MSOP-8L package is also included.

AG920-07 - GT Sensor Evaluation Kit

NVE's newest evaluation kit includes analog and digital version of the GT sensor product line, plus our DD001-12 stand alone signal processing IC. A variety of PCB configurations are provided so that the parts can be tested in different housing and barrel sizes, including the M8 housing. Magnets for biasing are also included, along with NVE's catalog and application notes on CD ROM.

Evaluation kits may be ordered direct from NVE's web site, or from our authorized distributors. See NVE's web site for the list of authorized distributors.

Analog Sensor and Current Sensor Evaluation Kits

AG001-01 Analog Sensor Evaluation Kit

The NVE GMR Engineering Evaluation Kit (PN AG001-01) was created as an aid to the technical user of GMR sensors to facilitate laboratory experimentation and development. The kit consists of an assortment of NVE sensors, printed circuit boards and permanent magnets sufficient to demonstrate sensor functionality in the laboratory. The kit consists of the following:

Part Number	Quantity	Description
AA002-02	2	15 Oe/5 k Ω Field Sensor
AAH002-02	1	7.5 Oe/5 k Ω Field Sensor
AAL002-02	1	15 Oe/5 k Ω Field Low Hysteresis Sensor
AA003-02	2	20 Oe/5 k Ω Field Sensor
AA004-02	2	50 Oe/5 k Ω Field Sensor
AA005-02	2	100 Oe/5 k Ω Field Sensor
AA006-02	2	50 Oe/30 k Ω Field Sensor
AB001-02	2	250 Oe/5 k Ω Field Gradient Sensor
AG004-06	2	Long PCB- 3.0" x 0.3"
AG005-06	2	Square PCB- 0.5" x 0.5"
SN 12031	2	Ceramic 5- Disc Magnets
SN 12030	2	Sintered 8 Alnico- Rectangular magnets
	1	Catalog and Application Notes on CD ROM



AG003-01 Current Sensor Evaluation Kit

The NVE GMR Current Sensor Evaluation Assembly (P/N AG003-01) was created to facilitate laboratory experimentation and development using GMR current sensors. The kit consists of (4) four NVE current sensors (P/N AA003-02) assembled to a printed circuit board (P/N AG002-01). Please note that the AA003-02 was selected for inclusion in this kit because it is a good medium sensitivity current sensor. In fact, any of NVE’s AA sensor products can be used in this application, for more or less sensitivity to the magnetic field generated by the current. The PCB included in the kit has (4) four trace geometries to simulate various PCB current ranges. The details are as follows:

Trace no.	Trace Width (inches)	Maximum ¹ Trace Input Current (A)	Nominal Sensitivity ([mV/V] _{out} /A _{in})
1	0.090	±9.0	3.5
2	0.060	±6.0	3.7
3	0.010	±0.25	4.0
4	7X 0.010	±0.25	20.0

Notes:

1. The maximum current is based on the rated current carrying capability of each trace geometry.
2. The minimum current the assembly can sense is arbitrary. The absolute value is dependent on many system design parameters and must be determined by the user.
3. For functional characteristics of the AA003-02 current sensor, refer to the AA Sensors section of this catalog.
4. Refer to NVE’s Engineering & Application Notes, Appendix APP 003, “GMR Current Sensing” for additional technical details.
5. The AG003-01 assembly can be subdivided into (4) four separate sub-assemblies. All connections to each input trace and current sensor are isolated on each sub-section.

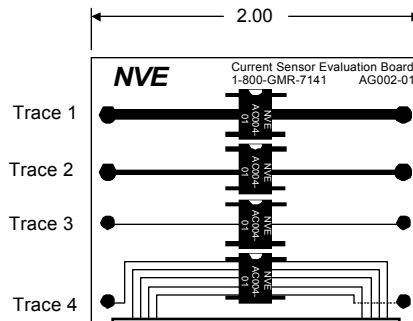

GMR Switch and GT Sensor Evaluation Kits

AG910-07, AG911-07 GMR Switch Evaluation Kit

These kits were created to facilitate laboratory experimentation and development using NVE’s GMR Switch Digital Output Sensors. The kits consist of sixteen distinct NVE GMR Switches that span the magnetic field range and output types available in the AD series sensors. All sensors in this kit are packaged in the MSOP8 miniature surface mount package. The kits also include a ceramic bar magnet, and printed circuit boards (PCBs) for testing in the actual application, In addition, the AG910-07 kit includes a high temperature (175°C) MSOP8 ZIF socket with Kelvin contacts.



GMR Switch Digital Evaluation Kits Parts List

Part Designator	Part Marking	Output type	Description
AD004-00	BBH	Single Current Sink	See GMR Switch Section of This Catalog
AD005-00	BBG		
AD006-00	BBJ		
AD020-00	BBK		
AD021-00	BBB		
AD022-00	BBC		
AD023-00	BBD		
AD024-00	BBF		
ADH025-00	MBL		
AD105-00	DBG		
AD122-00	DBC	“	
AD824-00	MBF	Dual Output with SCP	
AD924-00	NBF	“	
AD320-00	GBK	Sink/Sink	
AD324-00	GBF	“	
AD624-00	KBF	Sink/Source/Vreg	
AD724-00	LBF	Sink/Sink/Vreg	
AG910-06	N/A	N/A	1”x2” PCB Board (AG910-07 Kit Only)
AG918-06	N/A	N/A	.25” X 2” PCB Board
AG919-06	N/A	N/A	.25” X 2” PCB Board
	N/A	N/A	CD ROM Catalog/App Notes
SN 12100	N/A	N/A	MSOP8 ZIF Socket (AG910-07 Kit Only)
SN 12032	N/A	N/A	Ceramic Magnet,1”x0.25”x0.39”

AG920-07 GT Sensor Evaluation Kit

This kit was created to facilitate laboratory experimentation and development using NVE’s GT Sensor products. Because of the wide variety of mechanical orientations where these sensors can be used, this kit contains a large variety of circuit boards, to simplify the customer’s fixturing and testing of the parts. Included in the kit are one of each type of NVE’s GT Sensor products, both analog and digital, plus two of the DD001-12 signal processing ICs, to convert the analog output of the ABL sensors to a digital output. Also included is a small container of solder paste, with instructions on soldering to the TDFN-SO8 package. The contents of each kit are listed below:



Quantity	Part Number	Marking	Description
1	ABL004-00	FDB	Single Differential Sensor, 1.0mm Element Spacing
1	ABL005-00	FDC	Single Differential Sensor, 0.5mm Element Spacing
1	ABL014-00	FDD	Dual Differential Sensor, 1.0mm Element Spacing, 0.5mm Phase Shift
1	ABL015-00	FDK	Dual Differential Sensor, 0.5mm Element Spacing, 0.25mm Phase Shift
1	AKL001-12	P/N	Digital Output Differential Sensor, 1.0mm Element Spacing
1	AKL002-12	P/N	Digital Output Differential Sensor, 0.5mm Element Spacing
2	DD001-12	P/N	Digital Output Signal Processing IC for ABL Sensors
2	AG915-06	N/A	M8 Round PCB, for mounting ABL Sensor
2	AG914-06	N/A	M10 Round PCB, for mounting AKL Sensor
1	AG918-06	N/A	Long, Narrow PCB for Mounting ABL Sensor Parallel to Long axis
1	AG919-06	N/A	Long, Narrow PCB for Mounting ABL Sensor Perpendicular to Long axis
1	AG913-06	N/A	PCB for Mounting 2 DD001-02 ICs
1	AG916-06	N/A	Long, Narrow PCB for Mounting AKL Sensor Parallel to Long axis
1	AG917-06	N/A	Long, Narrow PCB for Mounting AKL Sensor Perpendicular to Long axis
1	AG911-06	N/A	Long, Narrow PCB for Mounting ABL Sensors Parallel to Long axis, and 1 or 2 DD001-12 ICs
1	AG912-06	N/A	Long, Narrow PCB for Mounting ABL Sensors Perpendicular to Long axis, and 1 or 2 DD001-12 ICs
5	N/A	N/A	6mm Diameter X 4mm Thick Round Ferrite Magnets
5	N/A	N/A	3.5mm Diameter X 4mm Thick Round Ferrite Magnets
1	N/A	N/A	Catalog and Application Notes on CD ROM
1	N/A	N/A	Small container of solder paste

Appendix Package Drawings and Specifications

Package Drawing – SOIC8

Note: SOIC8 Package has thermal power dissipation of 240°C/Watt in free air. Attaching the package to a circuit board improves thermal performance.

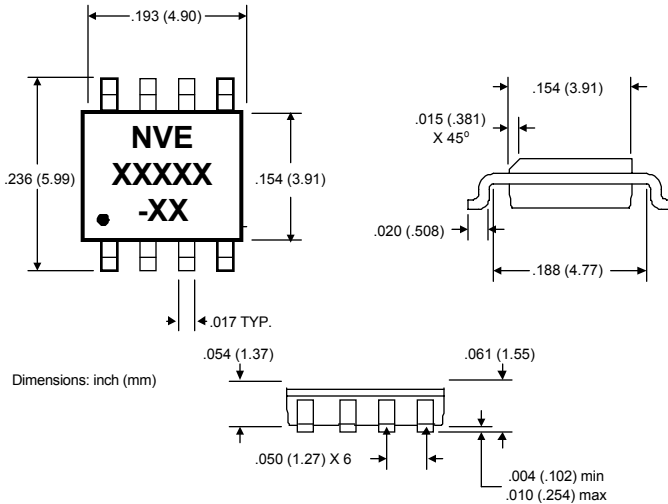

Package Drawing – MSOP8

Note: MSOP8 Package has thermal power dissipation of 320°C/Watt in free air. Attaching the package to a circuit board improves thermal performance.

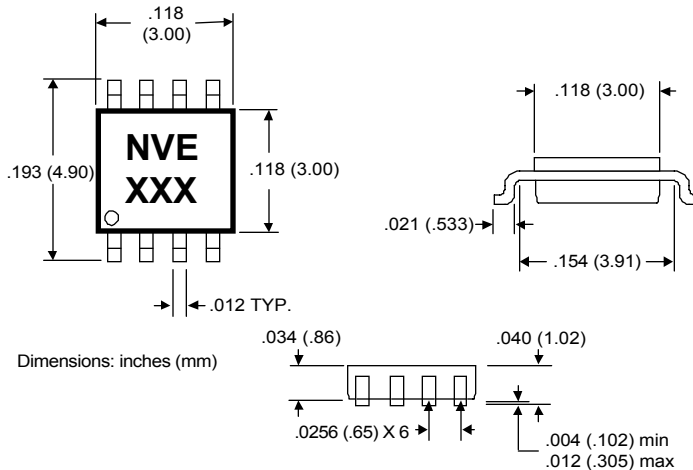

Package Drawing – TDFN6 2.5mm X 2.5mm

Note: Dimensions in mm. TDFN6 package has thermal power dissipation of 320°C/Watt in free air. Attaching the package to a circuit board improves thermal performance.

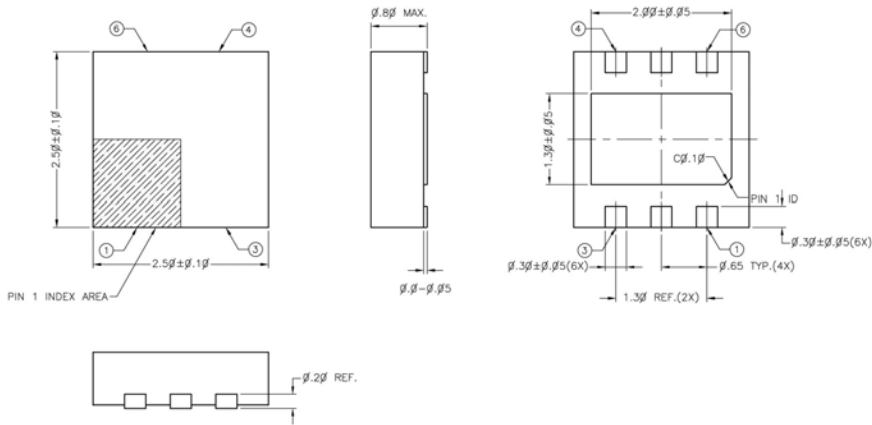

Package Drawing – TDFN SO8

Note: Dimensions in mm. TDFN SO8 Package has thermal power dissipation of 240°C/Watt in free air. Attaching the package to a circuit board improves thermal performance.

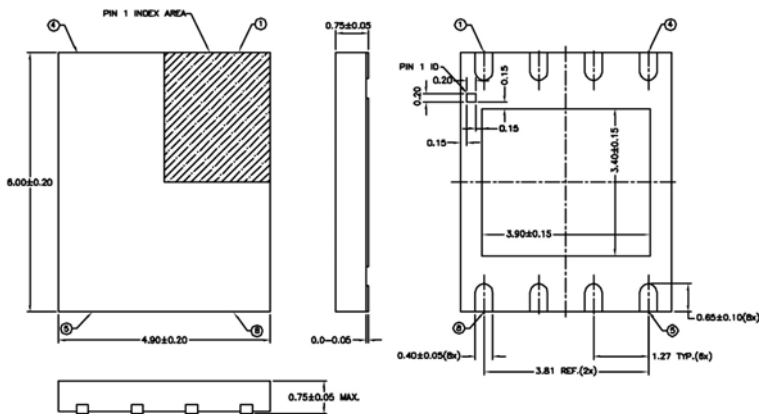

Part Numbers and Marking Codes

Some of NVE’s products are delivered in packages that are too small to be marked with the complete part number. In these cases, a 3 letter code is used to identify the part. The following table provides a cross-reference:

NVE Part Number	Code
AA004-00	CDB
AA006-00	CBC
AAH004-00	CBF
AB001-00	CBG
ABH001-00	CBH
ABL004-00	FDB
ABL005-00	FDC
ABL014-00	FDD
ABL015-00	FDG
ABL004-10	FDG
ABL005-10	FDH
ABL014-10	FDJ
ABL015-10	FDK
AD004-00	BBH
AD005-00	BBG
AD006-00	BBJ
AD020-00	BBK
AD021-00	BBB
AD022-00	BBC
AD023-00	BBD
AD024-00	BBF
AD104-00	DBH
AD105-00	DBG
AD106-00	DBJ
AD120-00	DBK
AD121-00	DBB
AD122-00	DBC
AD123-00	DBD
AD124-00	DBF
AD204-00	FBH
AD205-00	FBG
AD206-00	FBJ
AD220-00	FBK
AD221-00	FBB
AD222-00	FBC
AD223-00	FBD
AD224-00	FBF
AD304-00	GBH
AD305-00	GBG
AD306-00	GBJ
AD320-00	GBK
AD321-00	GBB
AD322-00	GBC
AD323-00	GBD
AD324-00	GBF
AD404-00	HBH
AD405-00	HBG
AD406-00	HBJ

NVE Part Number	Code
AD420-00	HBK
AD421-00	HBB
AD422-00	HBC
AD423-00	HBD
AD424-00	HBF
AD504-00	JBH
AD505-00	JBG
AD506-00	JBJ
AD520-00	JBK
AD521-00	JBB
AD522-00	JBC
AD523-00	JBD
AD524-00	JBF
AD604-00	KBH
AD605-00	KBG
AD606-00	KBJ
AD620-00	KBK
AD621-00	KBB
AD622-00	KBC
AD623-00	KBD
AD624-00	KBF
AD704-00	LBH
AD705-00	LBG
AD706-00	LBJ
AD720-00	LBK
AD721-00	LBB
AD722-00	LBC
AD723-00	LBD
AD724-00	LBF
AD081-00	BDB
AD082-00	BDC
AD083-00	BDD
AD084-00	BDF
AD821-00	MBB
AD822-00	MBC
AD823-00	MBD
AD824-00	MBF
AD921-00	NBB
AD922-00	NBC
AD923-00	NBD
AD924-00	NBF
ADH025-00	MBL
DB001-00	FFD
DC001-10	FFB
DC002-10	FFC
BD012-00	ZBF

Definitions and Conversion Factors

Definitions:

CSK or Sink: Current sinking output, also referred to as Open Collector output.

Differential: The field difference between the Operate Point and the Release Point.

Electrical Offset: The inherent imbalance of the bridge expressed in differential voltage output.

HBM: Human Body Model for ESD specifications.

Hysteresis: The maximum deviation in volts between the output with increasing field and the output with decreasing field, where the applied field is unipolar (applied in either a positive or negative direction, without crossing the zero field point), divided by Voltage Span. Expressed as a percentage.

Input Voltage Range: The voltage range that can be applied across the bridge.

IOL (Current Output Low): The output current in the low (logic 0) state (output stage switched on).

Max Output: A specification given in millivolts per applied voltage. This is the maximum output voltage possible. This output condition is achieved when one set of resistors is in magnetic saturation (have achieved the maximum resistance change possible) while the other pair are at zero applied magnetic field.

Nonlinearity: The maximum deviation from a linear fit taken over the Field Range divided by the Voltage Span. Expressed as a percentage.

Off-axis Characteristic: A specification that describes the variation in sensor output versus the angle between the applied field direction and the sensitive axis of the GMR sensor with constant electrical and magnetic inputs applied. Applicable to non-integrated bridge sensors. The output will vary as the cosine of the angle rotated.

Operate Point: The field level which produces a logical change in state from “0” to “1” in NVE’s digital magnetic field sensors ADXXX-XX.

Operating Frequency: Frequency range which will produce a responsive output.

Output Leakage Current (Current Output High): The output current in the high (logic 1) state (output stage switched off).

Output Saturation Voltage (Voltage Output Low): The output voltage in the low (logic 0) state (output stage switched on).

RBP: Reverse Battery Protection.

Release Point: The field level which produces a logical change in state from “1” to “0” in NVE’s digital magnetic field sensors ADXXX-XX.

Resistor Separation: This is the mean separation between the two pairs of resistors, in a Gradiometer or Differential sensor.

Sensitivity: A measure of the output magnitude based on electrical and magnetic input conditions. Expressed in millivolts of differential output per applied voltage per oersted.

Specified Linear Range: Typically 70% of the field it takes to saturate the part. Field dependent specifications are based upon this range.

TCOI (Temperature Coefficient of Output at Constant Input Current): The variation of the output voltage over temperature with a constant input current applied. Expressed as a percentage per unit temperature change.

TCOV (Temperature Coefficient of Output at Constant Input Voltage): The variation of the output voltage over temperature with a constant input voltage applied. Expressed as a percentage per unit temperature change.

TCR (Temperature Coefficient of Resistance): The variation of the GMR resistors over temperature. Expressed as a percentage per unit temperature change.

Voltage Span: The differential output voltage taken from zero to 70% of the saturation field level.

Conversion Factors

To Convert	Into	Multiply by
μWb	maxwell	10^2
A/cm	Oe	1.256
A/m	Oe	1.256×10^{-2}
At	Gb	1.256
G	Oe	1 (when $\mu_o=1$)
G	T	10^{-4}
G	mT	10^{-1}
G	nT	10^5
G	Wb/cm^2	10^{-8}
G	Wb/in^2	6.452×10^{-8}
G	Wb/m^2	10^{-4}
Gb	At	0.796
kA/m	Oe	1.256×10^1
maxwell	Wb	10^{-8}
maxwell	μWb	10^{-2}
mT	G	10
maxwell	volt second	10^{-8}
nT	G	10^{-5}
nT	gamma (γ)	1
Oe	A/cm	7.962×10^{-1}
Oe	A/m	7.962×10^1
Oe	kA/m	7.962×10^{-2}
T	G	10^4
T	Wb/m^2	1
volt second	maxwell	10^8
volt second	Wb	1
Wb	maxwell	10^8
Wb/cm^2	G	10^8
Wb/m^2	G	10^4

NVE Company Profile

NVE Corporation is a high technology components manufacturer having the unique capability to combine leading edge Giant Magnetoresistive (GMR) materials with integrated circuits to make novel electronic components. Starting as a research and development only company in 1989, NVE has consistently discovered, developed, and patented manufacturable GMR materials and products over the last 13 years. NVE is now recognized as the world leader in GMR technology, and investments in NVE from companies such as Motorola and Cypress Semiconductor underscore this leadership.

In 1995, NVE's sensors business unit sprung from the results of the company's early efforts, and NVE became the first company in the world to offer a production magnetic sensor product based on GMR technology. Since that first product introduction, NVE's GMR sensor line has grown to encompass a wide variety of analog and digital sensor ICs, related signal processing ICs, and printed circuit board assemblies for specific sensor applications. These products place NVE at the forefront of the magnetic sensors market in a variety of application areas, including industrial speed and position sensing, magnetic media detection, field sensing in medical applications, and current sensing.

NVE's research into basic GMR materials continues unabated, resulting in a steady stream of new, high performance GMR materials and designs that can be incorporated into commercial sensor products. This wellspring of cutting edge technology ensures that NVE's products will be the market leaders for years to come.

NVE is located in Eden Prairie, Minnesota, USA, a suburb of Minneapolis. Please visit our web site or call our toll free number for information on products, sales, or distribution.

NVE Corporation
11409 Valley View Road
Eden Prairie, MN 55344
USA
Telephone: 800-467-7141
Fax: 952-829-9189
Internet: www.nve.com
e-mail: info@nve.com

NVE reserves the right to make changes to its sensor products to improve quality, reliability, and functionality. NVE does not assume any liability arising out of the application or use of these sensors.