

15-213

“The course that gives CMU its Zip!”

Machine-Level Programming I: Introduction Sept. 04, 2008

Topics

- Assembly Programmer’s Execution Model
- Accessing Information
 - Registers
 - Memory
- Arithmetic operations

IA32 Processors

Totally Dominate Computer Market

Evolutionary Design

- Starting in 1978 with 8086
- Added more features as time goes on
- Still support old features, although obsolete

Complex Instruction Set Computer (CISC)

- Many different instructions with many different formats
 - But, only small subset encountered with Linux programs
- Hard to match performance of Reduced Instruction Set Computers (RISC)
- But, Intel has done just that!

x86 Evolution: Programmer's View (Abbreviated)

Name	Date	Transistors
8086	1978	29K
<ul style="list-style-type: none">■ 16-bit processor. Basis for IBM PC & DOS■ Limited to 1MB address space. DOS only gives you 640K		
386	1985	275K
<ul style="list-style-type: none">■ Extended to 32 bits. Added “flat addressing”■ Capable of running Unix■ Referred to as “IA32”■ 32-bit Linux/gcc uses no instructions introduced in later models		

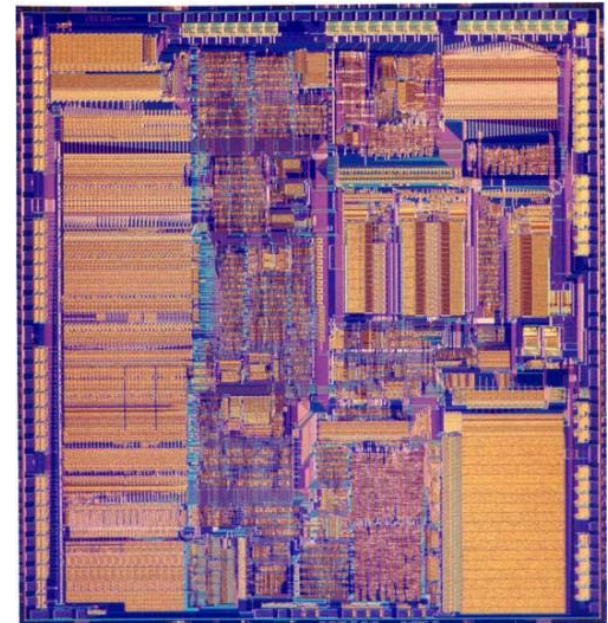
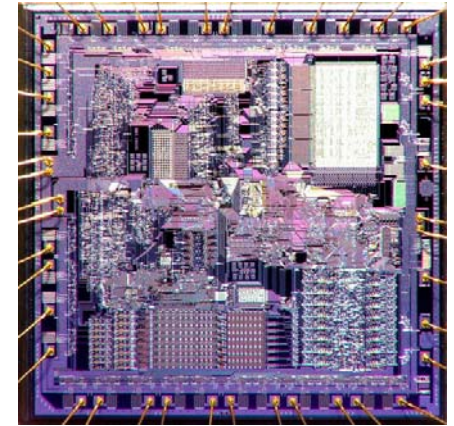

x86 Evolution: Programmer's View

Machine Evolution

■ 486	1989	1.9M
■ Pentium	1993	3.1M
■ Pentium/MMX	1997	4.5M
■ PentiumPro	1995	6.5M
■ Pentium III	1999	8.2M
■ Pentium 4	2001	42M
■ Core Duo	2006	291M

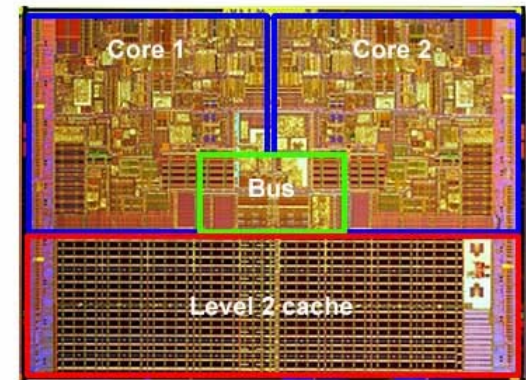

Added Features

- Instructions to support multimedia operations
 - Parallel operations on 1, 2, and 4-byte data, both integer & FP
- Instructions to enable more efficient conditional operations

Linux/GCC Evolution

- 4 - ■ None!

New Species: IA64

Name	Date	Transistors
Itanium	2001	10M
<ul style="list-style-type: none">■ Extends to IA64, a 64-bit architecture■ Radically new instruction set designed for high performance■ Can run existing IA32 programs<ul style="list-style-type: none">● On-board “x86 engine”■ Joint project with Hewlett-Packard		
Itanium 2	2002	221M
<ul style="list-style-type: none">■ Big performance boost		
Itanium 2 Dual-Core	2006	1.7B
Itanium has not taken off in marketplace		
<ul style="list-style-type: none">■ Lack of backward compatibility		

X86 Evolution: Clones

Advanced Micro Devices (AMD)

- **Historically**
 - AMD has followed just behind Intel
 - A little bit slower, a lot cheaper
- **Recently**
 - Recruited top circuit designers from Digital Equipment Corp. and other downward trending companies
 - Exploited fact that Intel distracted by IA64
 - Now are close competitors to Intel
- **Developed x86-64, its own extension to 64 bits**
 - Started eating into Intel's high-end server market

Intel's 64-Bit Dilemma

Intel Attempted Radical Shift from IA32 to IA64

- Totally different architecture
- Executes IA32 code only as legacy
- Performance disappointing

AMD Stepped in with Evolutionary Solution

- x86-64 (now called "AMD64")

Intel Felt Obligated to Focus on IA64

- Hard to admit mistake or that AMD is better

2004: Intel Announces EM64T extension to IA32

- Extended Memory 64-bit Technology
- Almost identical to x86-64!
- Our Saltwater fish machines

Our Coverage

IA32

- The traditional x86

x86-64

- The emerging standard

Presentation

- Book has IA32
- Handout has x86-64
- Lecture will cover both

Labs

- Lab #2 x86-64
- Lab #3 IA32

Assembly Programmer's View

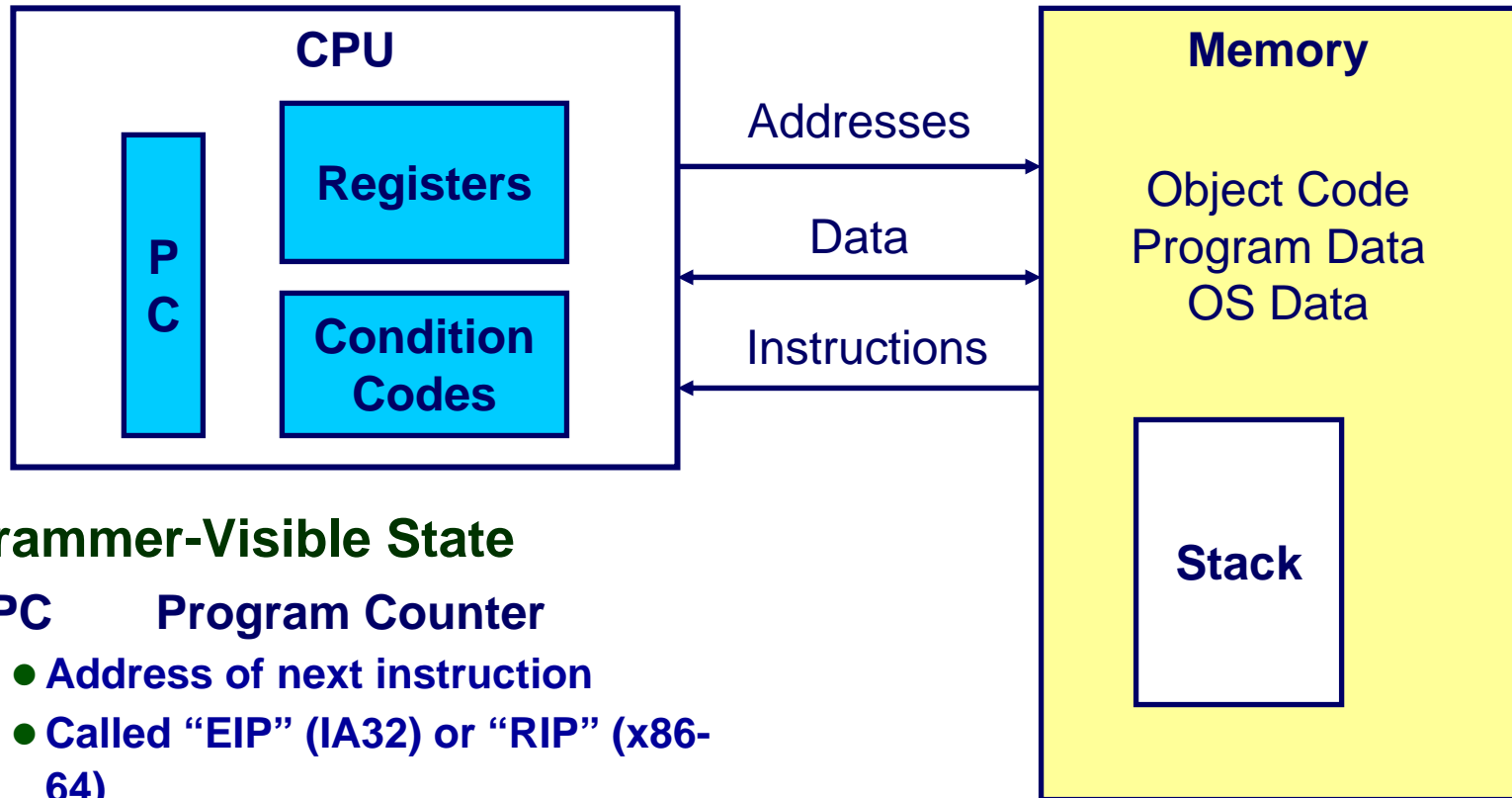

Programmer-Visible State

- **PC** Program Counter
 - Address of next instruction
 - Called “EIP” (IA32) or “RIP” (x86-64)
- **Register File**
 - Heavily used program data
- **Condition Codes**
 - Store status information about most recent arithmetic operation
 - Used for conditional branching

■ Memory

- Byte addressable array
- Code, user data, (some) OS data
- Includes stack used to support procedures

Turning C into Object Code

- Code in files `p1.c` `p2.c`
- Compile with command: `gcc -O p1.c p2.c -o p`
 - Use optimizations (`-O`)
 - Put resulting binary in file `p`

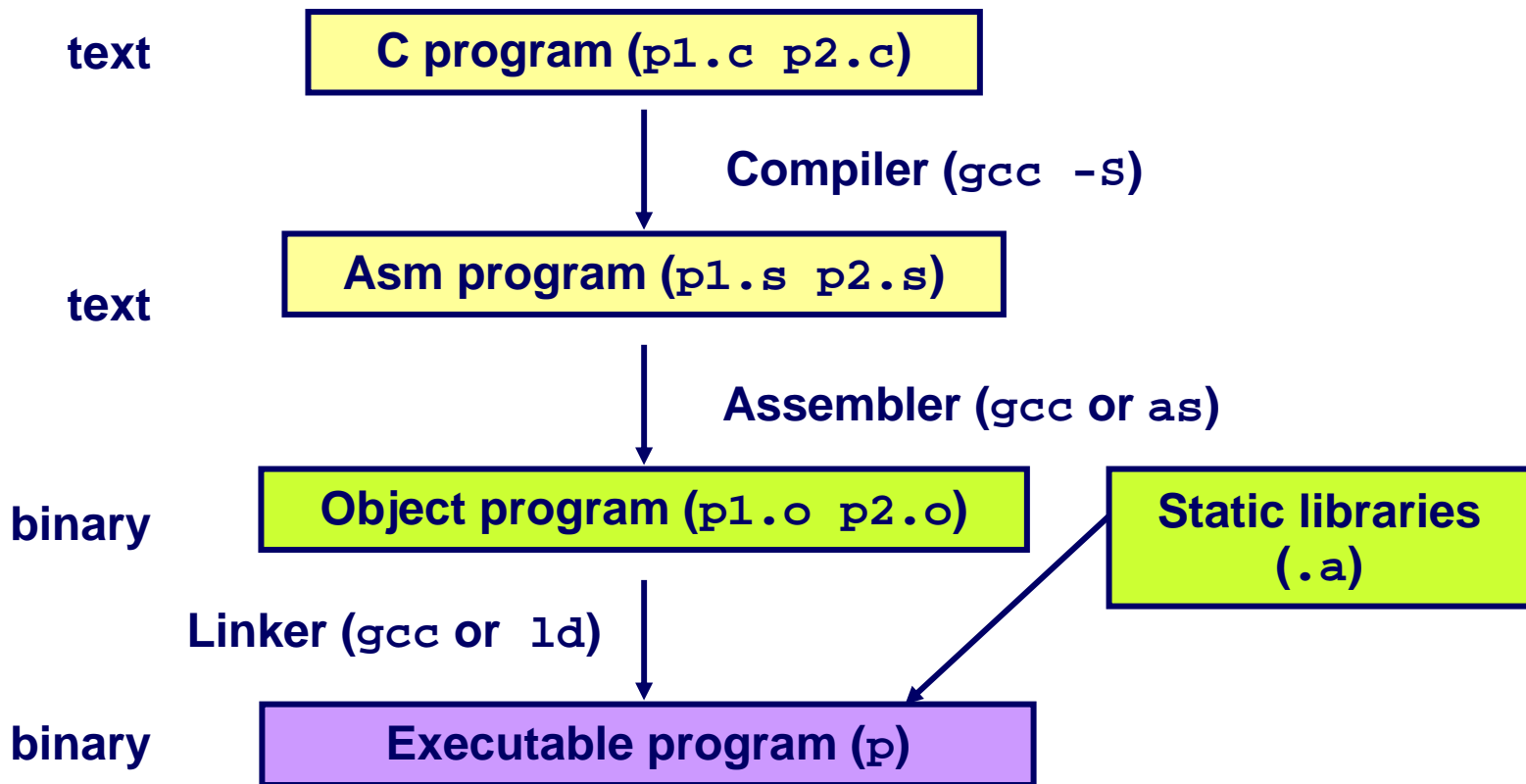

Compiling Into Assembly

C Code

```
int sum(int x, int y)
{
    int t = x+y;
    return t;
}
```

Generated IA32 Assembly

```
_sum:
    pushl %ebp
    movl %esp,%ebp
    movl 12(%ebp),%eax
    addl 8(%ebp),%eax
    movl %ebp,%esp
    popl %ebp
    ret
```

Obtain with command

```
gcc -O -S code.c
```

Produces file `code.s`

Assembly Characteristics

Minimal Data Types

- “Integer” data of 1, 2, or 4 bytes
 - Data values
 - Addresses (untyped pointers)
- Floating point data of 4, 8, or 10 bytes
- No aggregate types such as arrays or structures
 - Just contiguously allocated bytes in memory

Primitive Operations

- Perform arithmetic function on register or memory data
- Transfer data between memory and register
 - Load data from memory into register
 - Store register data into memory
- Transfer control
 - Unconditional jumps to/from procedures
 - Conditional branches

Object Code

Code for `sum`

0x401040 `<sum>`:

0x55

0x89

0xe5

0x8b

0x45

0x0c

0x03

0x45

0x08

0x89

0xec

0x5d

0xc3

- Total of 13 bytes
- Each instruction 1, 2, or 3 bytes
- Starts at address 0x401040

Assembler

- Translates `.s` into `.o`
- Binary encoding of each instruction
- Nearly-complete image of executable code
- Missing linkages between code in different files

Linker

- Resolves references between files
- Combines with static run-time libraries
 - E.g., code for `malloc`, `printf`
- Some libraries are *dynamically linked*
 - Linking occurs when program begins execution

Machine Instruction Example

```
int t = x+y;
```

```
addl 8(%ebp),%eax
```

Similar to expression:

```
x += y
```

Or

```
int eax;  
int *ebp;  
eax += ebp[2]
```

```
0x401046:    03 45 08
```

C Code

- Add two signed integers

Assembly

- Add 2 4-byte integers
 - “Long” words in GCC parlance
 - Same instruction whether signed or unsigned

- Operands:

x: Register %eax

y: Memory M[%ebp+8]

t: Register %eax

» Return function value in %eax

Object Code

- 3-byte instruction
- Stored at address 0x401046

Disassembling Object Code

Disassembled

```
00401040 <_sum>:
  0:      55          push   %ebp
  1:      89 e5       mov    %esp,%ebp
  3:      8b 45 0c    mov    0xc(%ebp),%eax
  6:      03 45 08    add   0x8(%ebp),%eax
  9:      89 ec       mov    %ebp,%esp
  b:      5d          pop    %ebp
  c:      c3          ret
  d:      8d 76 00    lea   0x0(%esi),%esi
```

Disassembler

`objdump -d p`

- Useful tool for examining object code
- Analyzes bit pattern of series of instructions
- Produces approximate rendition of assembly code
- Can be run on either `a.out` (complete executable) or `.o` file

Alternate Disassembly

Object

```
0x401040:  
  0x55  
  0x89  
  0xe5  
  0x8b  
  0x45  
  0x0c  
  0x03  
  0x45  
  0x08  
  0x89  
  0xec  
  0x5d  
  0xc3
```

Disassembled

```
0x401040 <sum>:      push    %ebp  
0x401041 <sum+1>:      mov     %esp,%ebp  
0x401043 <sum+3>:      mov     0xc(%ebp),%eax  
0x401046 <sum+6>:      add    0x8(%ebp),%eax  
0x401049 <sum+9>:      mov     %ebp,%esp  
0x40104b <sum+11>:     pop     %ebp  
0x40104c <sum+12>:     ret  
0x40104d <sum+13>:     lea    0x0(%esi),%esi
```

Within gdb Debugger

```
gdb p  
disassemble sum
```

- Disassemble procedure

```
x/13b sum
```

- Examine the 13 bytes starting at sum

What Can be Disassembled?

```
% objdump -d WINWORD.EXE
```

```
WINWORD.EXE:      file format pei-i386
```

```
No symbols in "WINWORD.EXE".
```

```
Disassembly of section .text:
```

```
30001000 <.text>:
```

```
30001000:  55                push    %ebp
30001001:  8b ec            mov     %esp,%ebp
30001003:  6a ff            push   $0xffffffff
30001005:  68 90 10 00 30    push   $0x30001090
3000100a:  68 91 dc 4c 30    push   $0x304cdc91
```

- Anything that can be interpreted as executable code
- Disassembler examines bytes and reconstructs assembly source

Moving Data: IA32

Moving Data

`movl Source, Dest:`

- Move 4-byte (“long”) word
- Lots of these in typical code

Operand Types

- Immediate: Constant integer data
 - Like C constant, but prefixed with ‘\$’
 - E.g., \$0x400, \$-533
 - Encoded with 1, 2, or 4 bytes
- Register: One of 8 integer registers
 - But `%esp` and `%ebp` reserved for special use
 - Others have special uses for particular instructions
- Memory: 4 consecutive bytes of memory
 - Various “address modes”

<code>%eax</code>
<code>%edx</code>
<code>%ecx</code>
<code>%ebx</code>
<code>%esi</code>
<code>%edi</code>
<code>%esp</code>
<code>%ebp</code>

movl Operand Combinations

	Source	Dest	Src, Dest	C Analog
movl	<i>Imm</i>	<i>Reg</i>	movl \$0x4, %eax	temp = 0x4;
		<i>Mem</i>	movl \$-147, (%eax)	*p = -147;
	<i>Reg</i>	<i>Reg</i>	movl %eax, %edx	temp2 = temp1;
		<i>Mem</i>	movl %eax, (%edx)	*p = temp;
	<i>Mem</i>	<i>Reg</i>	movl (%eax), %edx	temp = *p;

Cannot do memory-memory transfer with a single instruction

Simple Addressing Modes

Normal **(R)** **Mem[Reg[R]]**

- Register R specifies memory address

```
movl (%ecx), %eax
```

Displacement **D(R)** **Mem[Reg[R]+D]**

- Register R specifies start of memory region
- Constant displacement D specifies offset

```
movl 8(%ebp), %edx
```

Using Simple Addressing Modes

```
void swap(int *xp, int *yp)
{
    int t0 = *xp;
    int t1 = *yp;
    *xp = t1;
    *yp = t0;
}
```

swap:

```
pushl %ebp
movl  %esp,%ebp
pushl %ebx
```

Set
Up

```
movl 12(%ebp),%ecx
movl 8(%ebp),%edx
movl (%ecx),%eax
movl (%edx),%ebx
movl %eax,(%edx)
movl %ebx,(%ecx)
```

Body

```
movl -4(%ebp),%ebx
movl %ebp,%esp
popl %ebp
ret
```

Finish

Using Simple Addressing Modes

```
void swap(int *xp, int *yp)
{
    int t0 = *xp;
    int t1 = *yp;
    *xp = t1;
    *yp = t0;
}
```

swap:

```
pushl %ebp
```

```
movl %esp,%ebp
```

```
pushl %ebx
```

Set
Up

```
movl 12(%ebp),%ecx
```

```
movl 8(%ebp),%edx
```

```
movl (%ecx),%eax
```

```
movl (%edx),%ebx
```

```
movl %eax,(%edx)
```

```
movl %ebx,(%ecx)
```

Body

```
movl -4(%ebp),%ebx
```

```
movl %ebp,%esp
```

```
popl %ebp
```

```
ret
```

Finish

Understanding Swap

```
void swap(int *xp, int *yp)
{
    int t0 = *xp;
    int t1 = *yp;
    *xp = t1;
    *yp = t0;
}
```

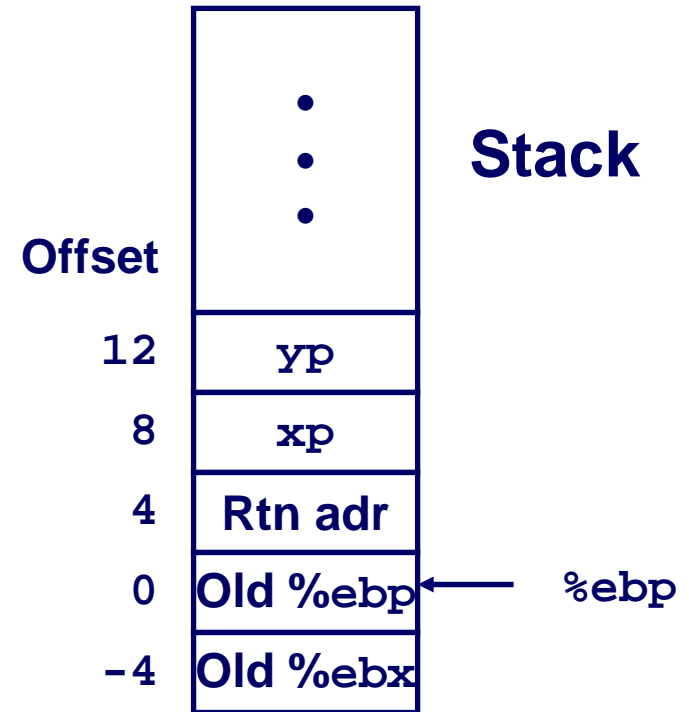

Register Variable

Register	Variable
%ecx	yp
%edx	xp
%eax	t1
%ebx	t0

```
movl 12(%ebp),%ecx # ecx = yp
movl 8(%ebp),%edx # edx = xp
movl (%ecx),%eax # eax = *yp (t1)
movl (%edx),%ebx # ebx = *xp (t0)
movl %eax,(%edx) # *xp = eax
movl %ebx,(%ecx) # *yp = ebx
```

Understanding Swap

%eax	
%edx	
%ecx	
%ebx	
%esi	
%edi	
%esp	
%ebp	0x104

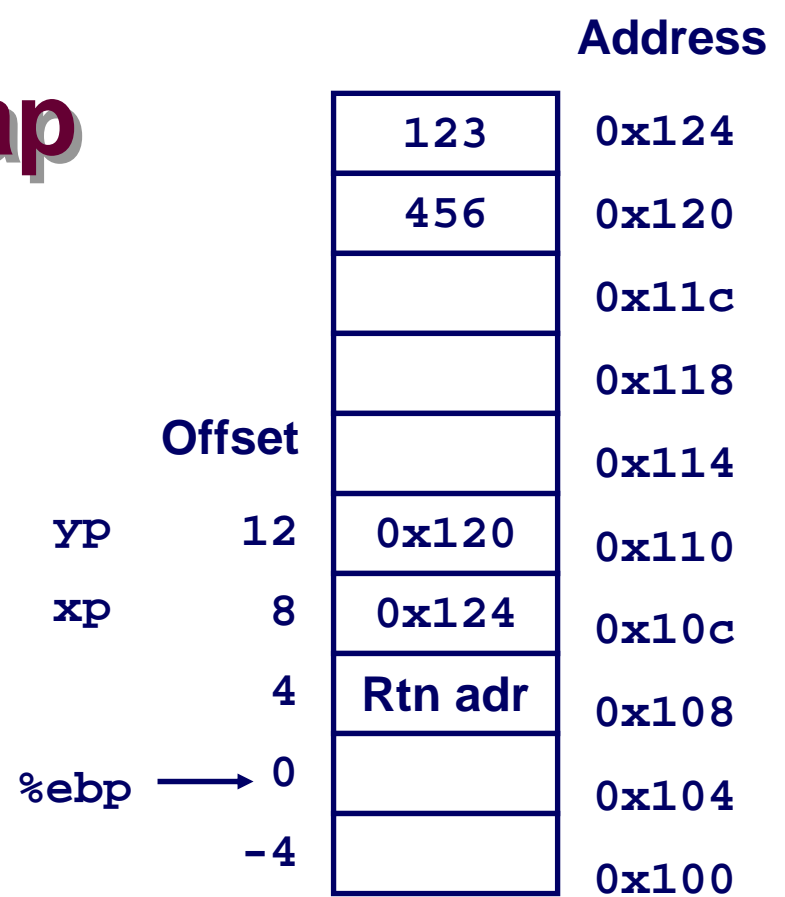

```

movl 12(%ebp),%ecx    # ecx = yp
movl 8(%ebp),%edx     # edx = xp
movl (%ecx),%eax      # eax = *yp (t1)
movl (%edx),%ebx      # ebx = *xp (t0)
movl %eax,(%edx)      # *xp = eax
movl %ebx,(%ecx)      # *yp = ebx
    
```

Understanding Swap

%eax	
%edx	
%ecx	0x120
%ebx	
%esi	
%edi	
%esp	
%ebp	0x104

		Address	
		123	0x124
		456	0x120
			0x11c
			0x118
	Offset		0x114
yp	12	0x120	0x110
xp	8	0x124	0x10c
	4	Rtn adr	0x108
%ebp	→ 0		0x104
	-4		0x100

```

movl 12(%ebp),%ecx    # ecx = yp
movl 8(%ebp),%edx     # edx = xp
movl (%ecx),%eax      # eax = *yp (t1)
movl (%edx),%ebx      # ebx = *xp (t0)
movl %eax,(%edx)      # *xp = eax
movl %ebx,(%ecx)      # *yp = ebx
    
```

Understanding Swap

%eax	
%edx	0x124
%ecx	0x120
%ebx	
%esi	
%edi	
%esp	
%ebp	0x104

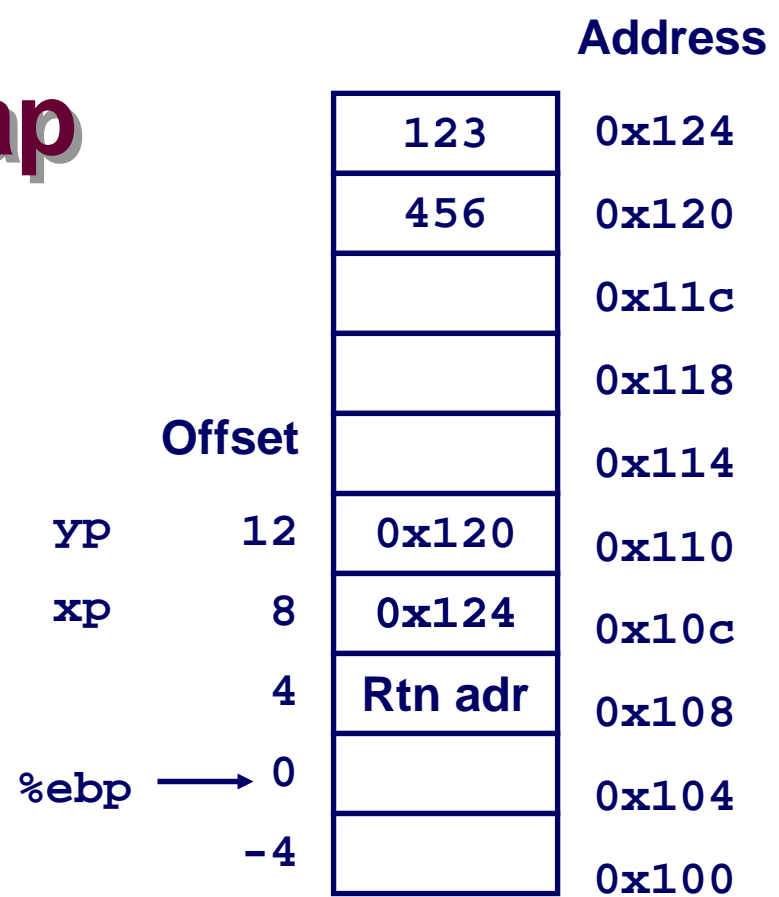

```

movl 12(%ebp),%ecx    # ecx = yp
movl 8(%ebp),%edx    # edx = xp
movl (%ecx),%eax     # eax = *yp (t1)
movl (%edx),%ebx     # ebx = *xp (t0)
movl %eax,(%edx)     # *xp = eax
movl %ebx,(%ecx)     # *yp = ebx
    
```

Understanding Swap

%eax	456
%edx	0x124
%ecx	0x120
%ebx	
%esi	
%edi	
%esp	
%ebp	0x104

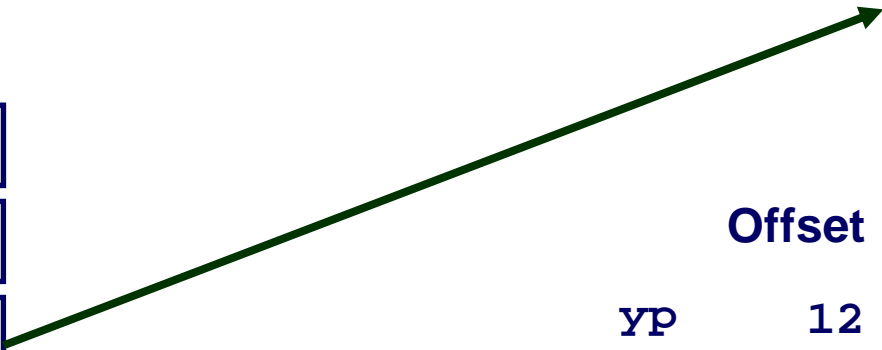

	Offset	Address
		0x124
		0x120
		0x11c
		0x118
		0x114
yp	12	0x120
xp	8	0x124
	4	Rtn adr
%ebp	0	0x104
	-4	0x100

```

movl 12(%ebp),%ecx    # ecx = yp
movl 8(%ebp),%edx     # edx = xp
movl (%ecx),%eax      # eax = *yp (t1)
movl (%edx),%ebx      # ebx = *xp (t0)
movl %eax,(%edx)      # *xp = eax
movl %ebx,(%ecx)      # *yp = ebx
  
```

Understanding Swap

%eax	456
%edx	0x124
%ecx	0x120
%ebx	123
%esi	
%edi	
%esp	
%ebp	0x104



	Offset		Address
		123	0x124
		456	0x120
			0x11c
			0x118
			0x114
yp	12	0x120	0x110
xp	8	0x124	0x10c
	4	Rtn adr	0x108
%ebp	0		0x104
	-4		0x100

```

movl 12(%ebp),%ecx    # ecx = yp
movl 8(%ebp),%edx     # edx = xp
movl (%ecx),%eax      # eax = *yp (t1)
movl (%edx),%ebx      # ebx = *xp (t0)
movl %eax,(%edx)      # *xp = eax
movl %ebx,(%ecx)      # *yp = ebx
    
```

Understanding Swap

%eax	456
%edx	0x124
%ecx	0x120
%ebx	123
%esi	
%edi	
%esp	
%ebp	0x104

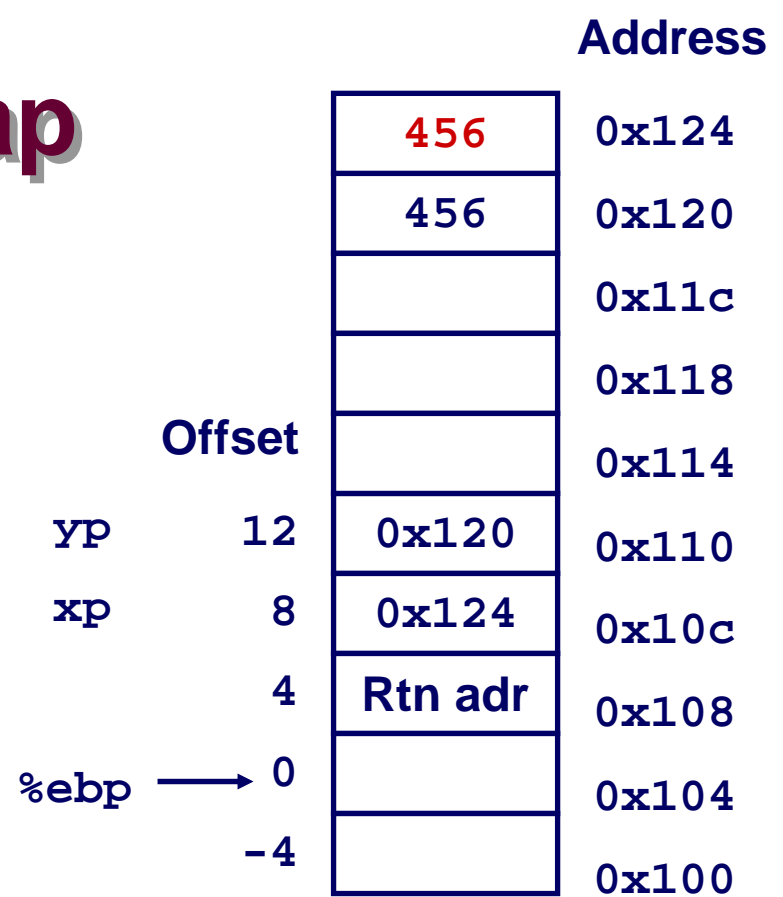

```

movl 12(%ebp),%ecx    # ecx = yp
movl 8(%ebp),%edx     # edx = xp
movl (%ecx),%eax      # eax = *yp (t1)
movl (%edx),%ebx      # ebx = *xp (t0)
movl %eax, (%edx)   # *xp = eax
movl %ebx, (%ecx)     # *yp = ebx
    
```

Understanding Swap

%eax	456
%edx	0x124
%ecx	0x120
%ebx	123
%esi	
%edi	
%esp	
%ebp	0x104

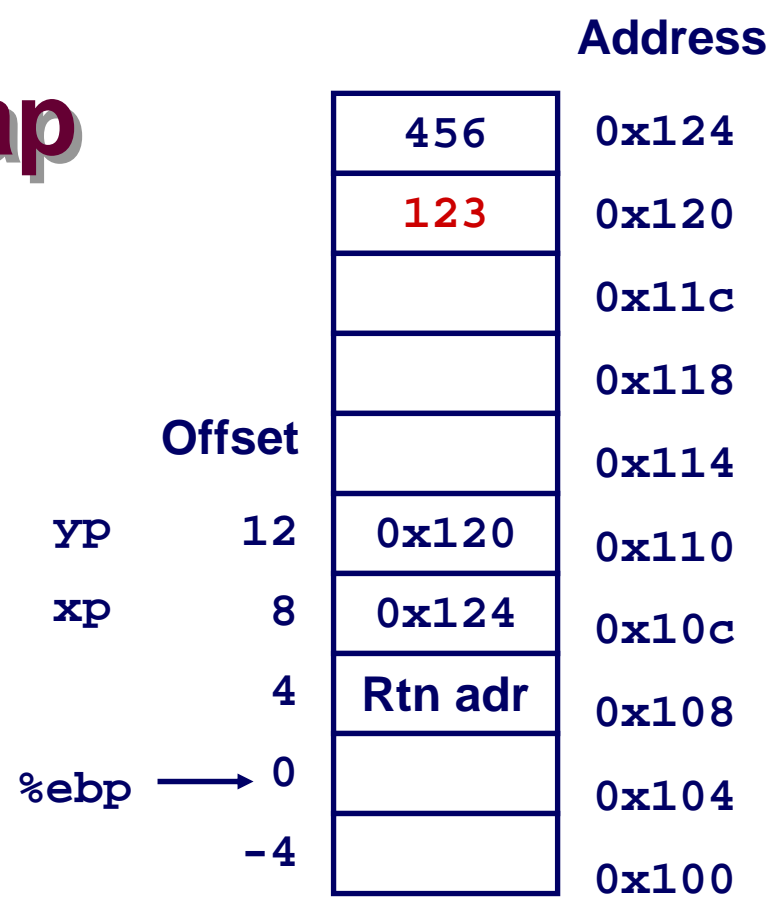

```

movl 12(%ebp),%ecx    # ecx = yp
movl 8(%ebp),%edx     # edx = xp
movl (%ecx),%eax      # eax = *yp (t1)
movl (%edx),%ebx      # ebx = *xp (t0)
movl %eax,(%edx)      # *xp = eax
movl %ebx,(%ecx)      # *yp = ebx
    
```

Indexed Addressing Modes

Most General Form

D(Rb,Ri,S) Mem[Reg[Rb]+S*Reg[Ri]+ D]

- **D:** Constant “displacement” 1, 2, or 4 bytes
- **Rb:** Base register: Any of 8 integer registers
- **Ri:** Index register: Any, except for %esp
 - Unlikely you’d use %ebp, either
- **S:** Scale: 1, 2, 4, or 8

Special Cases

(Rb,Ri) Mem[Reg[Rb]+Reg[Ri]]

D(Rb,Ri) Mem[Reg[Rb]+Reg[Ri]+D]

(Rb,Ri,S) Mem[Reg[Rb]+S*Reg[Ri]]

Address Computation Examples

<code>%edx</code>	<code>0xf000</code>
<code>%ecx</code>	<code>0x100</code>

Expression	Computation	Address
<code>0x8(%edx)</code>	<code>0xf000 + 0x8</code>	<code>0xf008</code>
<code>(%edx,%ecx)</code>	<code>0xf000 + 0x100</code>	<code>0xf100</code>
<code>(%edx,%ecx,4)</code>	<code>0xf000 + 4*0x100</code>	<code>0xf400</code>
<code>0x80(,%edx,2)</code>	<code>2*0xf000 + 0x80</code>	<code>0x1e080</code>

Address Computation Instruction

`leal Src, Dest`

- *Src* is address mode expression
- Set *Dest* to address denoted by expression

Uses

- Computing addresses without a memory reference
 - E.g., translation of `p = &x[i];`
- Computing arithmetic expressions of the form $x + k*y$
 - $k = 1, 2, 4, \text{ or } 8.$

Some Arithmetic Operations

Format

Computation

Two Operand Instructions

<code>addl</code>	<code>Src, Dest</code>	$Dest = Dest + Src$
<code>subl</code>	<code>Src, Dest</code>	$Dest = Dest - Src$
<code>imull</code>	<code>Src, Dest</code>	$Dest = Dest * Src$
<code>sall</code>	<code>Src, Dest</code>	$Dest = Dest \ll Src$ Also called <code>shll</code>
<code>sarl</code>	<code>Src, Dest</code>	$Dest = Dest \gg Src$ Arithmetic
<code>shrl</code>	<code>Src, Dest</code>	$Dest = Dest \gg Src$ Logical
<code>xorl</code>	<code>Src, Dest</code>	$Dest = Dest \wedge Src$
<code>andl</code>	<code>Src, Dest</code>	$Dest = Dest \& Src$
<code>orl</code>	<code>Src, Dest</code>	$Dest = Dest Src$

Some Arithmetic Operations

Format

Computation

One Operand Instructions

incl Dest

Dest = Dest + 1

decl Dest

Dest = Dest - 1

negl Dest

Dest = - Dest

notl Dest

Dest = ~ Dest

Using `leal` for Arithmetic Expressions

```
int arith
  (int x, int y, int z)
{
  int t1 = x+y;
  int t2 = z+t1;
  int t3 = x+4;
  int t4 = y * 48;
  int t5 = t3 + t4;
  int rval = t2 * t5;
  return rval;
}
```

arith:

```
pushl %ebp
movl %esp,%ebp
```

} Set Up

```
movl 8(%ebp),%eax
movl 12(%ebp),%edx
leal (%edx,%eax),%ecx
leal (%edx,%edx,2),%edx
sall $4,%edx
addl 16(%ebp),%ecx
leal 4(%edx,%eax),%eax
imull %ecx,%eax
```

} Body

```
movl %ebp,%esp
popl %ebp
ret
```

} Finish

Understanding arith

```
int arith
  (int x, int y, int z)
{
  int t1 = x+y;
  int t2 = z+t1;
  int t3 = x+4;
  int t4 = y * 48;
  int t5 = t3 + t4;
  int rval = t2 * t5;
  return rval;
}
```

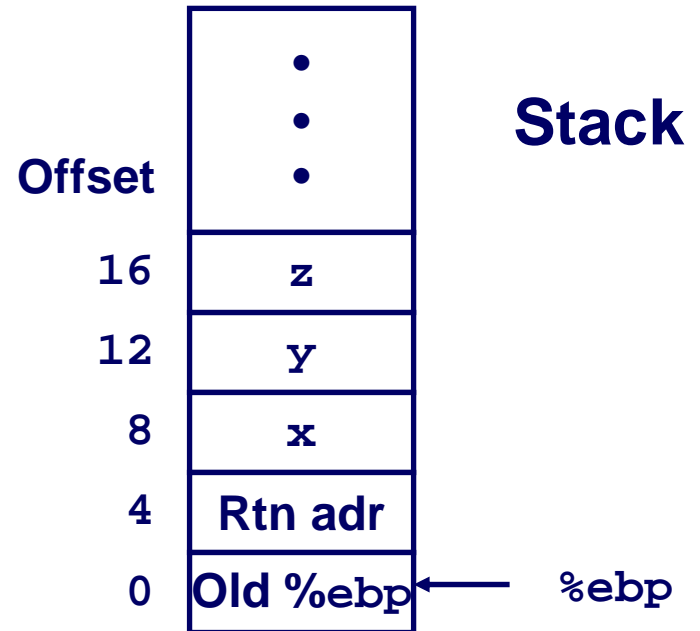

```
movl 8(%ebp),%eax      # eax = x
movl 12(%ebp),%edx     # edx = y
leal (%edx,%eax),%ecx  # ecx = x+y (t1)
leal (%edx,%edx,2),%edx # edx = 3*y
sall $4,%edx          # edx = 48*y (t4)
addl 16(%ebp),%ecx    # ecx = z+t1 (t2)
leal 4(%edx,%eax),%eax # eax = 4+t4+x (t5)
imull %ecx,%eax       # eax = t5*t2 (rval)
```

Understanding arith

```
int arith
(int x, int y, int z)
{
    int t1 = x+y;
    int t2 = z+t1;
    int t3 = x+4;
    int t4 = y * 48;
    int t5 = t3 + t4;
    int rval = t2 * t5;
    return rval;
}
```

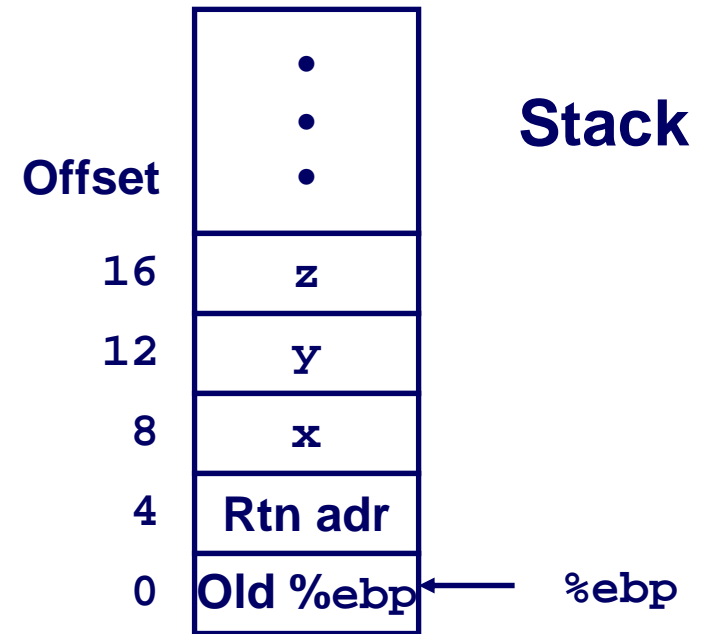

```
movl 8(%ebp),%eax      # eax = x
movl 12(%ebp),%edx     # edx = y
leal (%edx,%eax),%ecx  # ecx = x+y (t1)
leal (%edx,%edx,2),%edx # edx = 3*y
sall $4,%edx          # edx = 48*y (t4)
addl 16(%ebp),%ecx     # ecx = z+t1 (t2)
leal 4(%edx,%eax),%eax # eax = 4+t4+x (t5)
imull %ecx,%eax       # eax = t5*t2 (rval)
```

Understanding arith

```
int arith
(int x, int y, int z)
{
    int t1 = x+y;
    int t2 = z+t1;
    int t3 = x+4;
    int t4 = y * 48;
    int t5 = t3 + t4;
    int rval = t2 * t5;
    return rval;
}
```

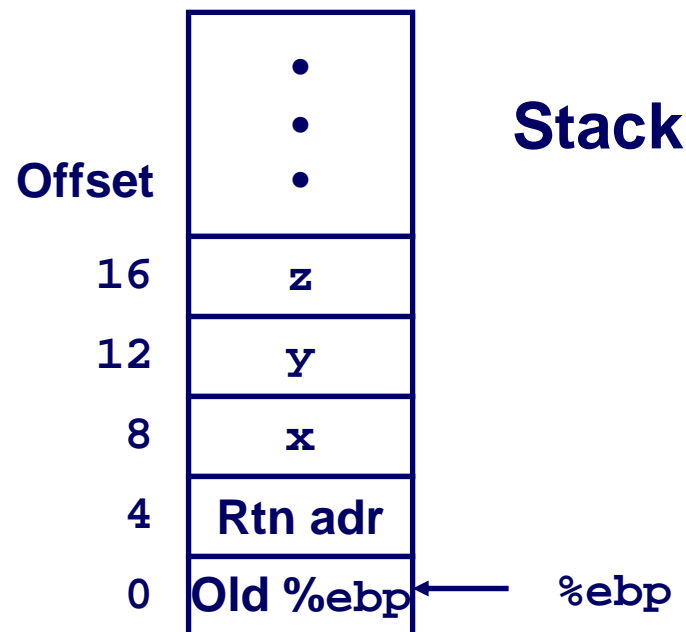

```
movl 8(%ebp),%eax      # eax = x
movl 12(%ebp),%edx     # edx = y
leal (%edx,%eax),%ecx  # ecx = x+y (t1)
leal (%edx,%edx,2),%edx # edx = 3*y
sall $4,%edx          # edx = 48*y (t4)
addl 16(%ebp),%ecx     # ecx = z+t1 (t2)
leal 4(%edx,%eax),%eax # eax = 4+t4+x (t5)
imull %ecx,%eax       # eax = t5*t2 (rval)
```

Understanding arith

```
int arith
(int x, int y, int z)
{
    int t1 = x+y;
    int t2 = z+t1;
    int t3 = x+4;
    int t4 = y * 48;
    int t5 = t3 + t4;
    int rval = t2 * t5;
    return rval;
}
```

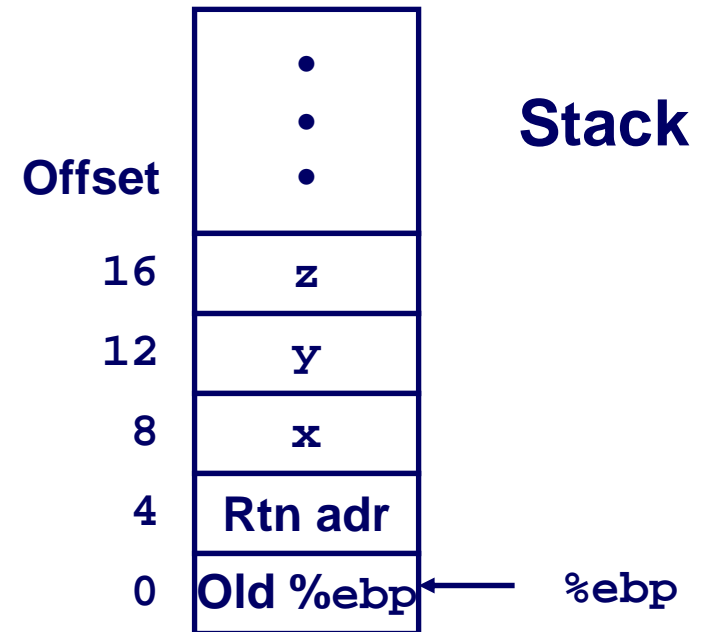

```
movl 8(%ebp),%eax      # eax = x
movl 12(%ebp),%edx     # edx = y
leal (%edx,%eax),%ecx  # ecx = x+y (t1)
leal (%edx,%edx,2),%edx # edx = 3*y
sall $4,%edx          # edx = 48*y (t4)
addl 16(%ebp),%ecx    # ecx = z+t1 (t2)
leal 4(%edx,%eax),%eax # eax = 4+t4+x (t5)
imull %ecx,%eax       # eax = t5*t2 (rval)
```

Understanding arith

```
int arith
(int x, int y, int z)
{
    int t1 = x+y;
    int t2 = z+t1;
    int t3 = x+4;
    int t4 = y * 48;
    int t5 = t3 + t4;
    int rval = t2 * t5;
    return rval;
}
```

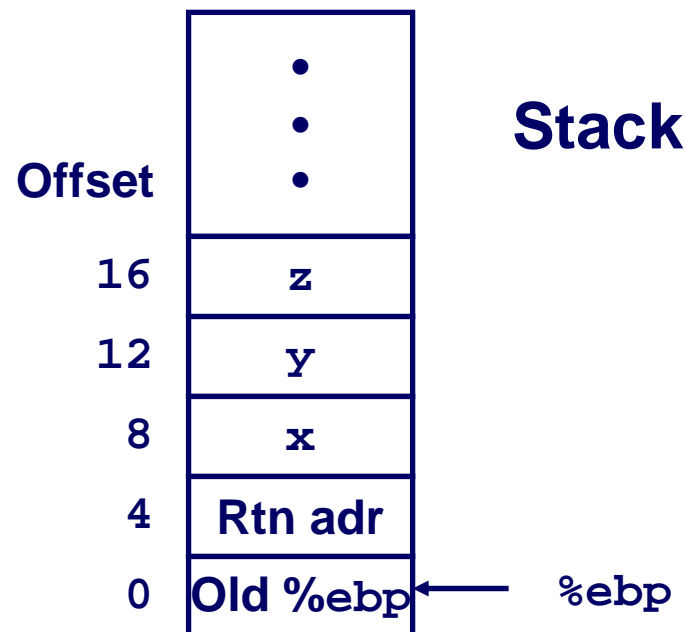

```
movl 8(%ebp),%eax      # eax = x
movl 12(%ebp),%edx     # edx = y
leal (%edx,%eax),%ecx  # ecx = x+y (t1)
leal (%edx,%edx,2),%edx # edx = 3*y
sall $4,%edx          # edx = 48*y (t4)
addl 16(%ebp),%ecx     # ecx = z+t1 (t2)
leal 4(%edx,%eax),%eax # eax = 4+t4+x (t5)
imull %ecx,%eax       # eax = t5*t2 (rval)
```

Understanding arith

```
int arith
(int x, int y, int z)
{
    int t1 = x+y;
    int t2 = z+t1;
    int t3 = x+4;
    int t4 = y * 48;
    int t5 = t3 + t4;
    int rval = t2 * t5;
    return rval;
}
```

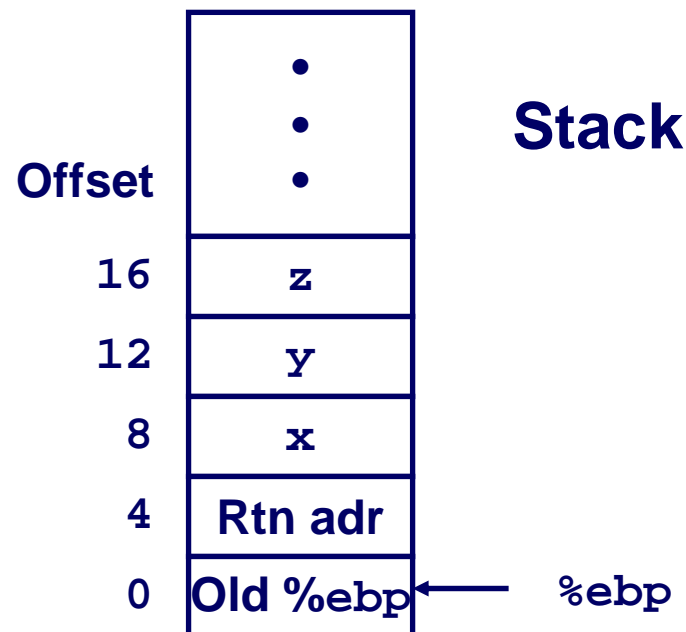

```
movl 8(%ebp),%eax      # eax = x
movl 12(%ebp),%edx     # edx = y
leal (%edx,%eax),%ecx  # ecx = x+y (t1)
leal (%edx,%edx,2),%edx # edx = 3*y
sall $4,%edx          # edx = 48*y (t4)
addl 16(%ebp),%ecx     # ecx = z+t1 (t2)
leal 4(%edx,%eax),%eax # eax = 4+t4+x (t5)
imull %ecx,%eax       # eax = t5*t2 (rval)
```

Another Example

```
int logical(int x, int y)
{
    int t1 = x^y;
    int t2 = t1 >> 17;
    int mask = (1<<13) - 7;
    int rval = t2 & mask;
    return rval;
}
```

logical:

```
    pushl %ebp
    movl  %esp,%ebp
```

} Set Up

```
    movl  8(%ebp),%eax
    xorl  12(%ebp),%eax
    sarl  $17,%eax
    andl  $8185,%eax
```

} Body

```
    movl  %ebp,%esp
    popl  %ebp
    ret
```

} Finish

```
movl  8(%ebp),%eax
xorl  12(%ebp),%eax
sarl  $17,%eax
andl  $8185,%eax
```

```
eax = x
eax = x^y
eax = t1>>17
eax = t2 & 8185
```

Another Example

```
int logical(int x, int y)
{
    int t1 = x^y;
    int t2 = t1 >> 17;
    int mask = (1<<13) - 7;
    int rval = t2 & mask;
    return rval;
}
```

logical:

```
pushl %ebp
movl %esp,%ebp
```

} Set Up

```
movl 8(%ebp),%eax
xorl 12(%ebp),%eax
sarl $17,%eax
andl $8185,%eax
```

} Body

```
movl %ebp,%esp
popl %ebp
ret
```

} Finish

```
movl 8(%ebp),%eax
xorl 12(%ebp),%eax
sarl $17,%eax
andl $8185,%eax
```

```
eax = x
eax = x^y      (t1)
eax = t1>>17  (t2)
eax = t2 & 8185
```

Another Example

```
int logical(int x, int y)
{
    int t1 = x^y;
    int t2 = t1 >> 17;
    int mask = (1<<13) - 7;
    int rval = t2 & mask;
    return rval;
}
```

logical:

```
pushl %ebp
movl %esp,%ebp
```

} Set Up

```
movl 8(%ebp),%eax
xorl 12(%ebp),%eax
sarl $17,%eax
andl $8185,%eax
```

} Body

```
movl %ebp,%esp
popl %ebp
ret
```

} Finish

```
movl 8(%ebp),%eax
xorl 12(%ebp),%eax
sarl $17,%eax
andl $8185,%eax
```

```
eax = x
eax = x^y      (t1)
eax = t1>>17  (t2)
eax = t2 & 8185
```

Another Example

```
int logical(int x, int y)
{
    int t1 = x^y;
    int t2 = t1 >> 17;
    int mask = (1<<13) - 7;
    int rval = t2 & mask;
    return rval;
}
```

$2^{13} = 8192, 2^{13} - 7 = 8185$

```
movl 8(%ebp),%eax
xorl 12(%ebp),%eax
sarl $17,%eax
andl $8185,%eax
```

logical:

```
pushl %ebp
movl %esp,%ebp
```

} Set Up

```
movl 8(%ebp),%eax
xorl 12(%ebp),%eax
sarl $17,%eax
andl $8185,%eax
```

} Body

```
movl %ebp,%esp
popl %ebp
ret
```

} Finish

```
eax = x
eax = x^y      (t1)
eax = t1>>17  (t2)
eax = t2 & 8185 (rval)
```

Data Representations: IA32 + x86-64

Sizes of C Objects (in Bytes)

■ C Data Type	Typical 32-bit	Intel IA32	x86-64
● unsigned	4	4	4
● int	4	4	4
● long int	4	4	8
● char	1	1	1
● short	2	2	2
● float	4	4	4
● double	8	8	8
● long double	8	10/12	16
● char *	4	4	8

» Or any other pointer

x86-64 General Purpose Registers

<code>%rax</code>	<code>%eax</code>
<code>%rdx</code>	<code>%edx</code>
<code>%rcx</code>	<code>%ecx</code>
<code>%rbx</code>	<code>%ebx</code>
<code>%rsi</code>	<code>%esi</code>
<code>%rdi</code>	<code>%edi</code>
<code>%rsp</code>	<code>%esp</code>
<code>%rbp</code>	<code>%ebp</code>

<code>%r8</code>	<code>%r8d</code>
<code>%r9</code>	<code>%r9d</code>
<code>%r10</code>	<code>%r10d</code>
<code>%r11</code>	<code>%r11d</code>
<code>%r12</code>	<code>%r12d</code>
<code>%r13</code>	<code>%r13d</code>
<code>%r14</code>	<code>%r14d</code>
<code>%r15</code>	<code>%r15d</code>

- Extend existing registers. Add 8 new ones.
- Make `%ebp/%rbp` general purpose

Swap in 32-bit Mode

```
void swap(int *xp, int *yp)
{
    int t0 = *xp;
    int t1 = *yp;
    *xp = t1;
    *yp = t0;
}
```

swap:

```
    pushl %ebp
    movl  %esp,%ebp
    pushl %ebx
```

Set
Up

```
    movl 12(%ebp),%ecx
    movl 8(%ebp),%edx
    movl (%ecx),%eax
    movl (%edx),%ebx
    movl %eax,(%edx)
    movl %ebx,(%ecx)
```

Body

```
    movl -4(%ebp),%ebx
    movl %ebp,%esp
    popl %ebp
    ret
```

Finish

Swap in 64-bit Mode

```
void swap(int *xp, int *yp)
{
    int t0 = *xp;
    int t1 = *yp;
    *xp = t1;
    *yp = t0;
}
```

```
swap:
    movl    (%rdi), %edx
    movl    (%rsi), %eax
    movl    %eax, (%rdi)
    movl    %edx, (%rsi)
    ret
```

- Operands passed in registers
 - First (`xp`) in `%rdi`, second (`yp`) in `%rsi`
 - 64-bit pointers
- No stack operations required
- 32-bit data
 - Data held in registers `%eax` and `%edx`
 - `movl` operation

Swap Long Ints in 64-bit Mode

```
void swap_l
(long int *xp, long int *yp)
{
    long int t0 = *xp;
    long int t1 = *yp;
    *xp = t1;
    *yp = t0;
}
```

```
swap_l:
    movq    (%rdi), %rdx
    movq    (%rsi), %rax
    movq    %rax, (%rdi)
    movq    %rdx, (%rsi)
    ret
```

■ 64-bit data

- Data held in registers `%rax` and `%rdx`
- `movq` operation
 - » “q” stands for quad-word

Summary

Machine Level Programming

- **Assembly code is textual form of binary object code**
- **Low-level representation of program**
 - **Explicit manipulation of registers**
 - **Simple and explicit instructions**
 - **Minimal concept of data types**
 - **Many C control constructs must be implemented with multiple instructions**

Formats

- **IA32: Historical x86 format**
- **x86-64: Big evolutionary step**