

Bits, Bytes, and Integers

15-213: Introduction to Computer Systems
2nd Lectures, May 23rd, 2013

Instructors:

Greg Kesden

Today: Bits, Bytes, and Integers

- **Representing information as bits**
- **Bit-level manipulations**
- **Integers**
 - Representation: unsigned and signed
 - Conversion, casting
 - Expanding, truncating
 - Addition, negation, multiplication, shifting
 - Summary
- **Representations in memory, pointers, strings**

Binary Representations

■ Base 2 Number Representation

- Represent 15213_{10} as 11101101101101_2
- Represent 1.20_{10} as $1.0011001100110011[0011]..._2$
- Represent 1.5213×10^4 as $1.1101101101101_2 \times 2^{13}$

■ Electronic Implementation

- Easy to store with bistable elements
- Reliably transmitted on noisy and inaccurate wires

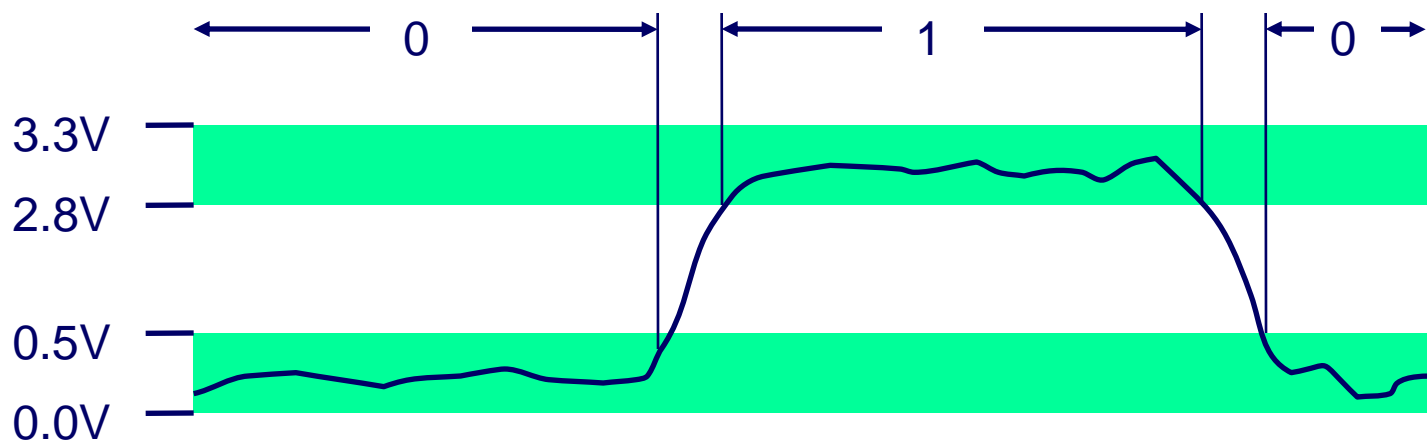

Encoding Byte Values

■ Byte = 8 bits

- Binary 00000000_2 to 11111111_2
- Decimal: 0_{10} to 255_{10}
- Hexadecimal 00_{16} to FF_{16}
 - Base 16 number representation
 - Use characters '0' to '9' and 'A' to 'F'
 - Write $FA1D37B_{16}$ in C as
 - `0xFA1D37B`
 - `0xfa1d37b`

Hex	Decimal	Binary
0	0	0000
1	1	0001
2	2	0010
3	3	0011
4	4	0100
5	5	0101
6	6	0110
7	7	0111
8	8	1000
9	9	1001
A	10	1010
B	11	1011
C	12	1100
D	13	1101
E	14	1110
F	15	1111

Data Representations

C Data Type	Typical 32-bit	Intel IA32	x86-64
char	1	1	1
short	2	2	2
int	4	4	4
long	4	4	8
long long	8	8	8
float	4	4	4
double	8	8	8
long double	8	10/12	10/16
pointer	4	4	8

Today: Bits, Bytes, and Integers

- Representing information as bits
- **Bit-level manipulations**
- Integers
 - Representation: unsigned and signed
 - Conversion, casting
 - Expanding, truncating
 - Addition, negation, multiplication, shifting
 - Summary
- Representations in memory, pointers, strings

Boolean Algebra

■ Developed by George Boole in 19th Century

- Algebraic representation of logic
 - Encode “True” as 1 and “False” as 0

And

- $A \& B = 1$ when both $A=1$ and $B=1$

$\&$	0	1
0	0	0
1	0	1

Or

- $A | B = 1$ when either $A=1$ or $B=1$

	0	1
0	0	1
1	1	1

Not

- $\sim A = 1$ when $A=0$

\sim	
0	1
1	0

Exclusive-Or (Xor)

- $A \wedge B = 1$ when either $A=1$ or $B=1$, but not both

\wedge	0	1
0	0	1
1	1	0

General Boolean Algebras

■ Operate on Bit Vectors

- Operations applied bitwise

01101001	01101001	01101001	01101001
& 01010101	01010101	^ 01010101	~ 01010101
01000001	01111101	00111100	10101010

■ All of the Properties of Boolean Algebra Apply

Example: Representing & Manipulating Sets

■ Representation

- Width w bit vector represents subsets of $\{0, \dots, w-1\}$
- $a_j = 1$ if $j \in A$

- 01101001 $\{0, 3, 5, 6\}$

- *76543210*

- 01010101 $\{0, 2, 4, 6\}$

- *76543210*

■ Operations

- & Intersection 01000001 $\{0, 6\}$
- | Union 01111101 $\{0, 2, 3, 4, 5, 6\}$
- ^ Symmetric difference 00111100 $\{2, 3, 4, 5\}$
- ~ Complement 10101010 $\{1, 3, 5, 7\}$

Bit-Level Operations in C

■ Operations $\&$, $|$, \sim , \wedge Available in C

- Apply to any “integral” data type
 - long, int, short, char, unsigned
- View arguments as bit vectors
- Arguments applied bit-wise

■ Examples (Char data type)

- $\sim 0x41 \rightarrow 0xBE$
 - $\sim 01000001_2 \rightarrow 10111110_2$
- $\sim 0x00 \rightarrow 0xFF$
 - $\sim 00000000_2 \rightarrow 11111111_2$
- $0x69 \& 0x55 \rightarrow 0x41$
 - $01101001_2 \& 01010101_2 \rightarrow 01000001_2$
- $0x69 | 0x55 \rightarrow 0x7D$
 - $01101001_2 | 01010101_2 \rightarrow 01111101_2$

Contrast: Logic Operations in C

- **Contrast to Logical Operators**
 - `&&`, `||`, `!`
 - View 0 as “False”
 - Anything nonzero as “True”
 - Always return 0 or 1
 - **Early termination**
- **Examples (char data type)**
 - `!0x41` → 0x00
 - `!0x00` → 0x01
 - `!!0x41` → 0x01

 - `0x69 && 0x55` → 0x01
 - `0x69 || 0x55` → 0x01
 - `p && *p` (avoids null pointer access)

Contrast: Logic Operations in C

■ Contrast to Logical Operators

- `&&`, `||`, `!`
 - View 0 as “False”
 - Anything nonzero
 - Always
 - Early

■ Example

- `!0x41` →
- `!0x00` →
- `!!0x41` →

- `0x69 && 0x55` → `0x01`
- `0x69 || 0x55` → `0x01`
- `p && *p` (avoids null pointer access)

**Watch out for `&&` vs. `&` (and `||` vs. `|`)...
one of the more common oopsies in
C programming**

Shift Operations

■ Left Shift: $x \ll y$

- Shift bit-vector x left y positions
 - Throw away extra bits on left
 - Fill with 0's on right

■ Right Shift: $x \gg y$

- Shift bit-vector x right y positions
 - Throw away extra bits on right
- Logical shift
 - Fill with 0's on left
- Arithmetic shift
 - Replicate most significant bit on left

■ Undefined Behavior

- Shift amount < 0 or \geq word size

Argument x	01100010
$\ll 3$	00010000
Log. $\gg 2$	00011000
Arith. $\gg 2$	00011000

Argument x	10100010
$\ll 3$	00010000
Log. $\gg 2$	00101000
Arith. $\gg 2$	11 101000

Today: Bits, Bytes, and Integers

- Representing information as bits
- Bit-level manipulations
- **Integers**
 - **Representation: unsigned and signed**
 - Conversion, casting
 - Expanding, truncating
 - Addition, negation, multiplication, shifting
 - Summary
- Representations in memory, pointers, strings
- Summary

Encoding Integers

Unsigned

$$B2U(X) = \sum_{i=0}^{w-1} x_i \cdot 2^i$$

Two's Complement

$$B2T(X) = -x_{w-1} \cdot 2^{w-1} + \sum_{i=0}^{w-2} x_i \cdot 2^i$$

```
short int x = 15213;
short int y = -15213;
```

Sign
Bit



■ C short 2 bytes long

	Decimal	Hex	Binary
x	15213	3B 6D	00111011 01101101
y	-15213	C4 93	11000100 10010011

■ Sign Bit

- For 2's complement, most significant bit indicates sign
 - 0 for nonnegative
 - 1 for negative

Two-complement Encoding Example (Cont.)

```

x =      15213: 00111011 01101101
y =     -15213: 11000100 10010011
  
```

Weight	15213		-15213	
1	1	1	1	1
2	0	0	1	2
4	1	4	0	0
8	1	8	0	0
16	0	0	1	16
32	1	32	0	0
64	1	64	0	0
128	0	0	1	128
256	1	256	0	0
512	1	512	0	0
1024	0	0	1	1024
2048	1	2048	0	0
4096	1	4096	0	0
8192	1	8192	0	0
16384	0	0	1	16384
-32768	0	0	1	-32768
Sum	15213		-15213	

Numeric Ranges

■ Unsigned Values

- $UMin = 0$
000...0
- $UMax = 2^w - 1$
111...1

■ Two's Complement Values

- $TMin = -2^{w-1}$
100...0
- $TMax = 2^{w-1} - 1$
011...1

■ Other Values

- Minus 1
111...1

Values for $W = 16$

	Decimal	Hex	Binary
UMax	65535	FF FF	11111111 11111111
TMax	32767	7F FF	01111111 11111111
TMin	-32768	80 00	10000000 00000000
-1	-1	FF FF	11111111 11111111
0	0	00 00	00000000 00000000

Values for Different Word Sizes

	W			
	8	16	32	64
UMax	255	65,535	4,294,967,295	18,446,744,073,709,551,615
TMax	127	32,767	2,147,483,647	9,223,372,036,854,775,807
TMin	-128	-32,768	-2,147,483,648	-9,223,372,036,854,775,808

■ Observations

- $|TMin| = TMax + 1$
 - Asymmetric range
- $UMax = 2 * TMax + 1$

■ C Programming

- `#include <limits.h>`
- Declares constants, e.g.,
 - `ULONG_MAX`
 - `LONG_MAX`
 - `LONG_MIN`
- Values platform specific

Unsigned & Signed Numeric Values

X	$B2U(X)$	$B2T(X)$
0000	0	0
0001	1	1
0010	2	2
0011	3	3
0100	4	4
0101	5	5
0110	6	6
0111	7	7
1000	8	-8
1001	9	-7
1010	10	-6
1011	11	-5
1100	12	-4
1101	13	-3
1110	14	-2
1111	15	-1

■ Equivalence

- Same encodings for nonnegative values

■ Uniqueness

- Every bit pattern represents a unique integer value
- Each representable integer has a unique bit encoding

■ \Rightarrow Can Invert Mappings

- $U2B(x) = B2U^{-1}(x)$
 - Bit pattern for unsigned integer
- $T2B(x) = B2T^{-1}(x)$
 - Bit pattern for two's comp integer

Today: Bits, Bytes, and Integers

- Representing information as bits
- Bit-level manipulations
- **Integers**
 - Representation: unsigned and signed
 - **Conversion, casting**
 - Expanding, truncating
 - Addition, negation, multiplication, shifting
 - Summary
- Representations in memory, pointers, strings

Mapping Between Signed & Unsigned

Two's Complement

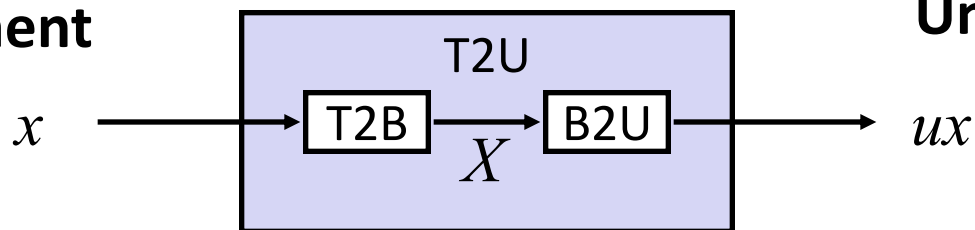

Unsigned

Maintain Same Bit Pattern

Unsigned

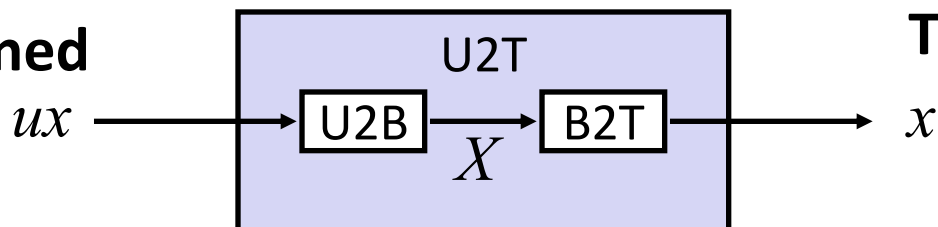

Two's Complement

Maintain Same Bit Pattern

- Mappings between unsigned and two's complement numbers:
keep bit representations and reinterpret

Mapping Signed \leftrightarrow Unsigned

Bits	Signed		Unsigned
0000	0	→	0
0001	1		1
0010	2	→	2
0011	3		3
0100	4	→	4
0101	5		5
0110	6	→	6
0111	7		7
1000	-8	←	8
1001	-7		9
1010	-6	←	10
1011	-5		11
1100	-4	←	12
1101	-3		13
1110	-2	←	14
1111	-1		15

→ **T2U** →
← **U2T** ←

Mapping Signed \leftrightarrow Unsigned

Bits	Signed	Unsigned
0000	0	0
0001	1	1
0010	2	2
0011	3	3
0100	4	4
0101	5	5
0110	6	6
0111	7	7
1000	-8	8
1001	-7	9
1010	-6	10
1011	-5	11
1100	-4	12
1101	-3	13
1110	-2	14
1111	-1	15

Diagram illustrating the mapping between Signed and Unsigned integer representations. The mapping is shown as a sequence of bit patterns (Bits) corresponding to Signed and Unsigned integer values.

The mapping is defined by the following relationship:

$$\text{Signed} = \text{Unsigned} \text{ for } \text{Signed} \in [0, 7]$$
$$\text{Signed} = \text{Unsigned} - 16 \text{ for } \text{Signed} \in [-8, -1]$$

The mapping is visualized by two double-headed arrows: the top arrow is labeled with an equals sign (=) and the bottom arrow is labeled with +/- 16.

Relation between Signed & Unsigned

Two's Complement

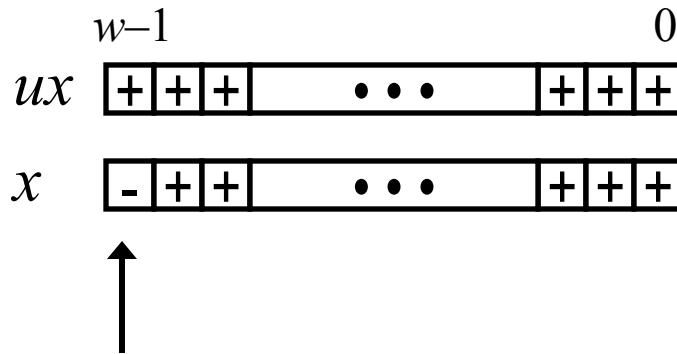
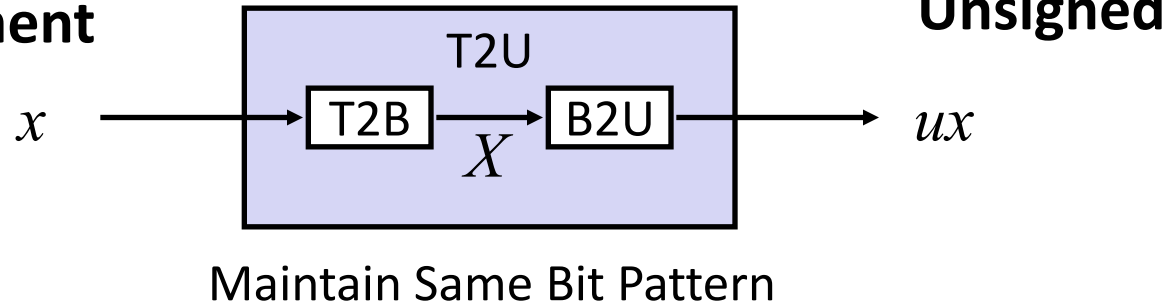

Large negative weight
becomes
 Large positive weight

Conversion Visualized

■ 2's Comp. → Unsigned

- Ordering Inversion
- Negative → Big Positive

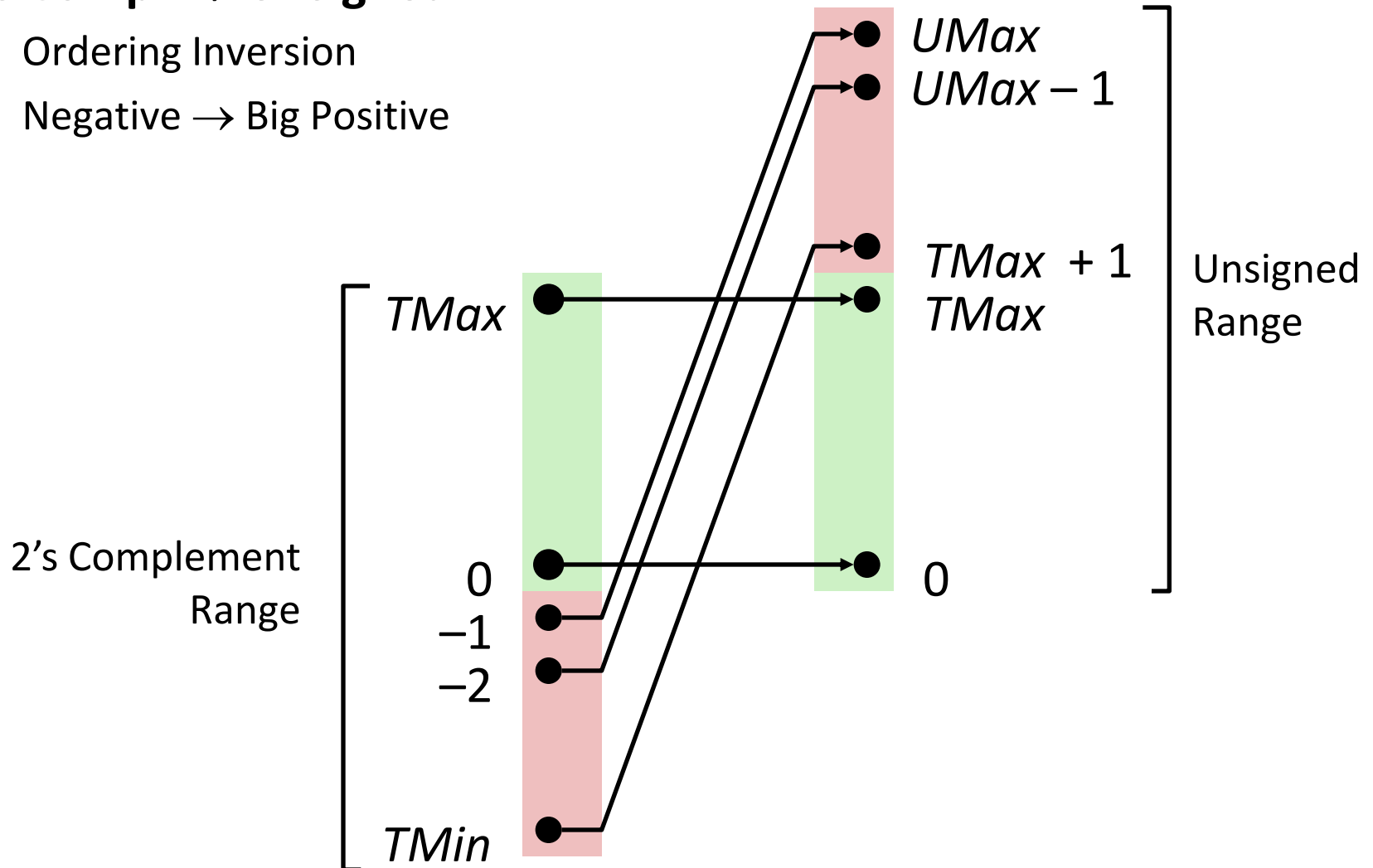

Signed vs. Unsigned in C

■ Constants

- By default are considered to be signed integers
- Unsigned if have “U” as suffix

`0U, 4294967259U`

■ Casting

- Explicit casting between signed & unsigned same as U2T and T2U

```
int tx, ty;
unsigned ux, uy;
tx = (int) ux;
uy = (unsigned) ty;
```

- Implicit casting also occurs via assignments and procedure calls

```
tx = ux;
uy = ty;
```

Casting Surprises

■ Expression Evaluation

- If there is a mix of unsigned and signed in single expression, *signed values implicitly cast to unsigned*
- Including comparison operations $<$, $>$, $==$, $<=$, $>=$
- Examples for $W = 32$: **TMIN = -2,147,483,648**, **TMAX = 2,147,483,647**

■ Constant ₁	Constant ₂	Relation	Evaluation
0	0U	==	unsigned
-1	0	<	signed
-1	0U	>	unsigned
2147483647	-2147483647-1	>	signed
2147483647U	-2147483647-1	<	unsigned
-1	-2	>	signed
(unsigned)-1	-2	>	unsigned
2147483647	2147483648U	<	unsigned
2147483647	(int) 2147483648U	>	signed

Summary

Casting Signed \leftrightarrow Unsigned: Basic Rules

- Bit pattern is maintained
- But reinterpreted
- Can have unexpected effects: adding or subtracting 2^w

- Expression containing signed and unsigned int
 - `int` is cast to `unsigned`!!