

**Lecture 12:**

# **A Basic Snooping-Based Multi-Processor Implementation**

---

**Parallel Computer Architecture and Programming  
CMU 15-418/15-618, Fall 2019**

# Today: implementing cache coherence

- Wait... haven't we talked about this before?
- Last week we talked about cache coherence protocols
  - But our discussion was very abstract
    - We described what messages/transactions needed to be sent
    - We assumed messages/transactions were atomic

Today we will talk about **efficiently implementing** an invalidation-based protocol

Today's point: in a real machine... **efficiently ensuring coherence is complex**

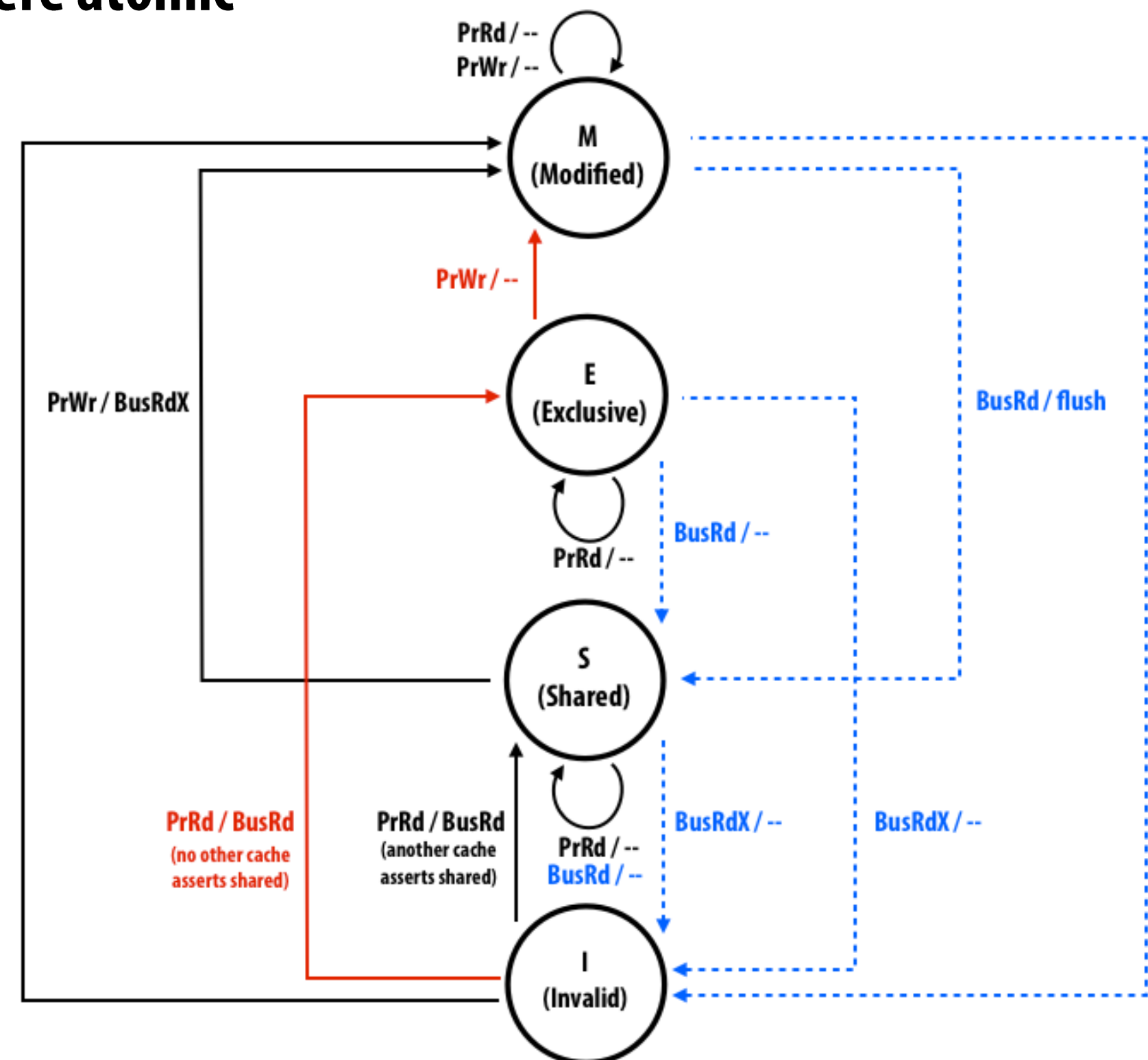

# **The concepts in today's lecture span much more than just hardware implementation**

- **The challenges and techniques we describe today (trade-offs between simplicity and performance, challenges of correctness in a parallel system) apply equally well to writing parallel programs**

# Review: MESI state transition diagram

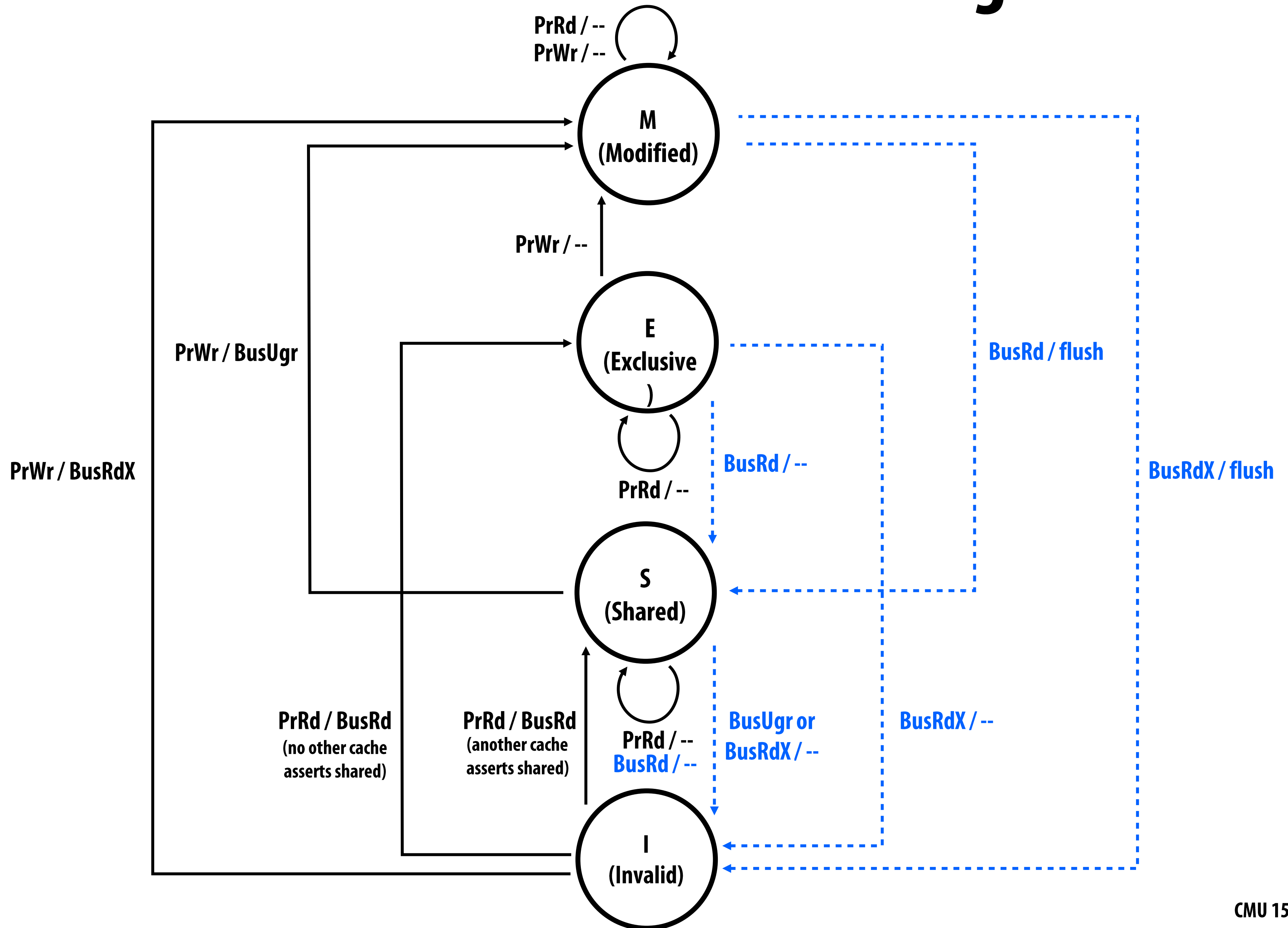

# Reality: multi-level cache hierarchies

Recall Intel Core i7 hierarchy

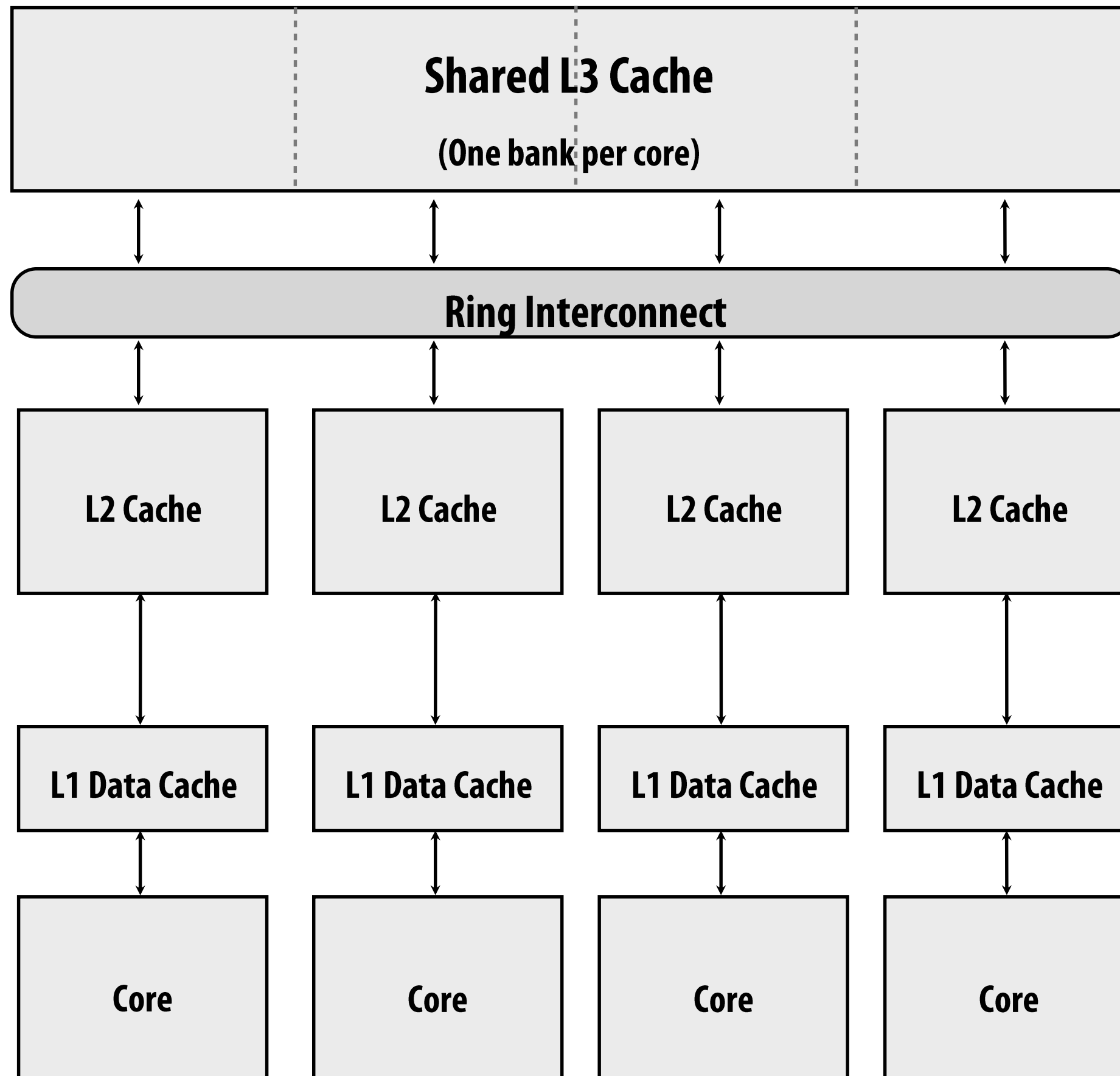

- **Challenge: changes made to data at first level cache may not be visible to second level cache controller than snoops the interconnect.**
- **How might snooping work for a cache hierarchy?**
  1. **All caches snoop interconnect independently? (inefficient)**
  2. **Maintain “inclusion”**

# The goals of our coherence implementation

## 1. Be **correct**

- Implements cache coherence

## 2. Achieve **high performance**

## 3. Minimize “**cost**” (e.g., minimize amount of extra hardware needed to implement coherence)

**As you will see...**

**Techniques that pursue high performance tend to make ensuring correctness tricky.**

# What you should know

- Concepts of **deadlock, livelock, and starvation**
- Have a basic understanding of **how a bus works**
  - But keep in mind most modern interconnects are NOT buses!  
(we'll have a whole lecture on interconnects soon)
- Understand **why maintaining coherence is challenging**, even when operating under simple machine design parameters
  - How do performance optimizations make correctness challenging?  
(e.g., how can deadlock, livelock, and starvation occur in coherence implementations, and how are these problems avoided?)
  - Your **mental model** of hardware should be: there are many components operating in parallel (even if abstractions don't indicate this is the case)

**Part 1:**  
**A basic implementation of snooping**  
**(assuming an atomic bus)**



# Consider a basic system design

- One outstanding memory request per processor
- Single level, write-back cache per processor
- Cache can stall processor as it is carrying out coherence operations
- System interconnect is an atomic shared bus (one cache communicates at a time)

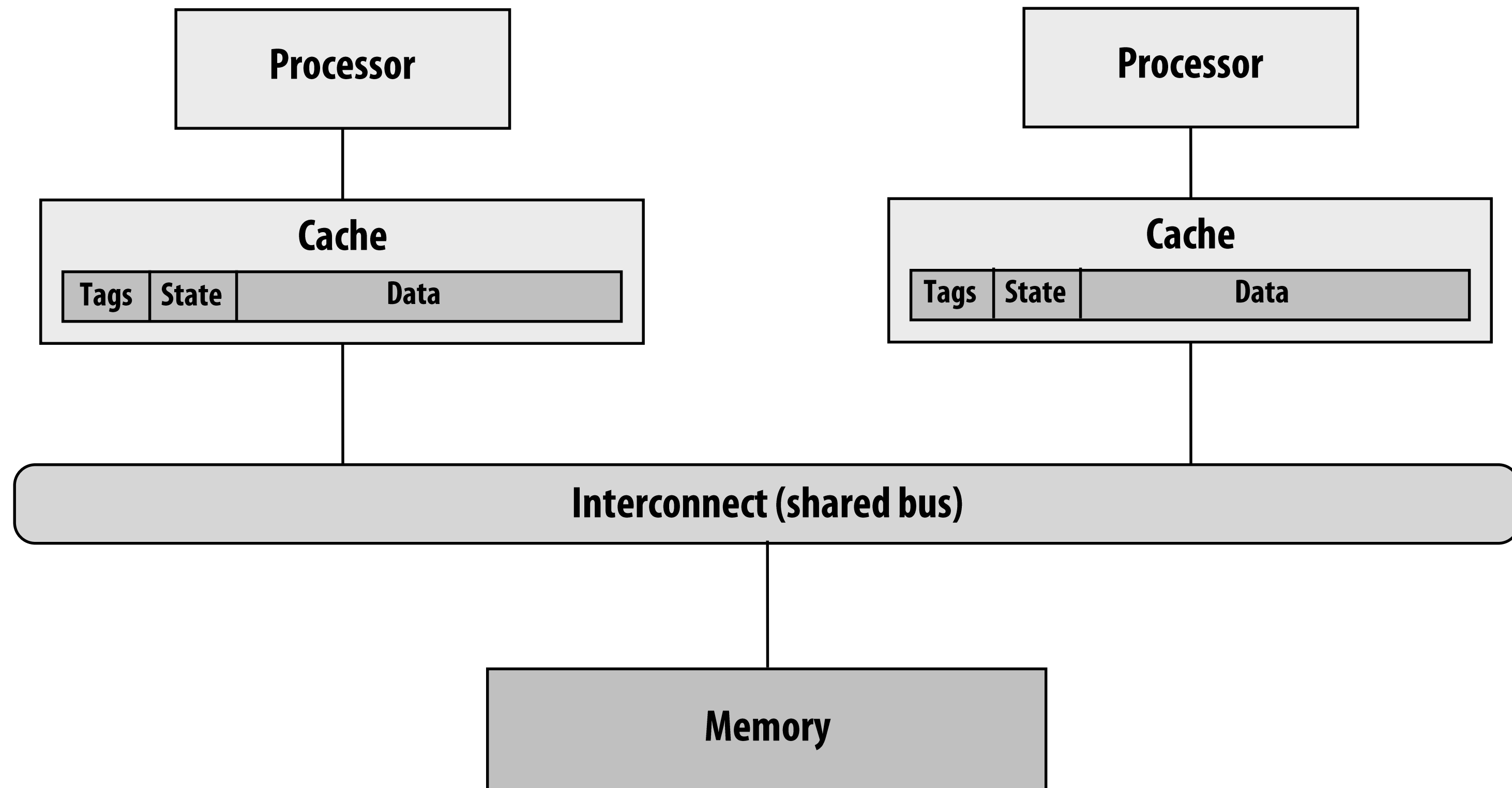

# Transaction on an atomic bus

1. Client is **granted bus** access (result of arbitration)
  2. Client places **command** on bus (may also place data on bus)
  3. **Response** to command by another bus client placed on bus
  4. Next client obtains bus access (arbitration)
- 

# Cache miss logic on a uniprocessor

1. Determine cache **set** (using appropriate bits of address)

2. Check cache **tags** (to determine if line is in cache)

*[Assume no matching tags, must read data from memory]*

3. Assert **request for access** to bus

4. Wait for **bus grant** (as determined by bus arbitrator)

5. Send **address + command on bus**

6. Wait for command to be accepted

7. **Receive data** on bus



What does atomic bus mean in a multi-processor scenario?

**BusRd, BusRdX:** no other bus transactions allowed between issuing address and receiving data

**Flush:** address and data sent simultaneously, received by memory before any other transaction allowed

# Multi-processor cache controller behavior

Challenge: both requests from processor and bus require **tag lookup**

This is another example of contention!

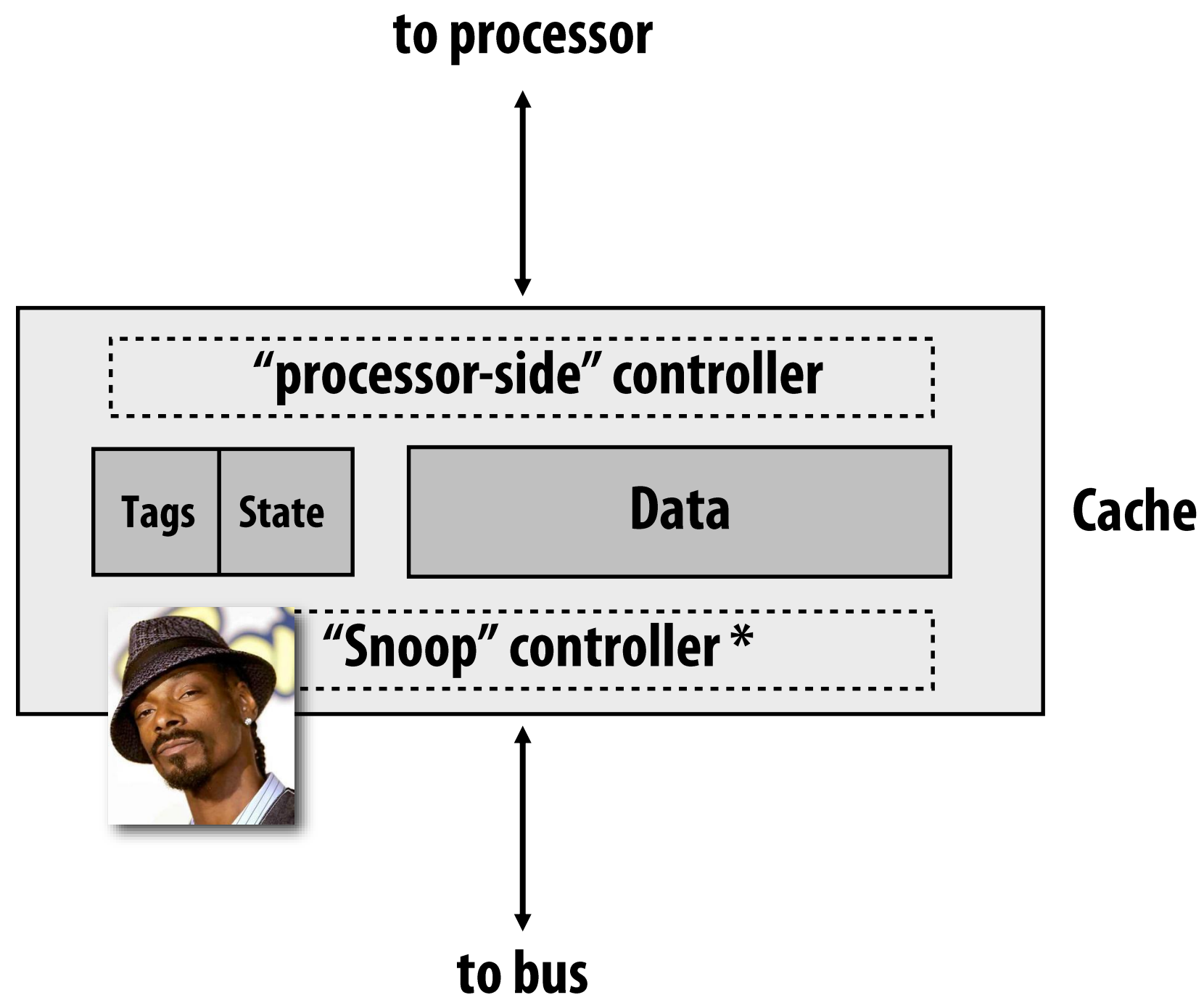

If bus receives priority:  
During bus transaction, processor is locked out from its own cache.

If processor receives priority:  
During processor cache accesses, cache cannot respond with its snoop result (so it delays other processors even if no sharing of any form is present)

\* Snoop controller has its mind on the bus and the bus on its mind

# Alleviate contention: allow simultaneous access by processor-side and snoop controllers

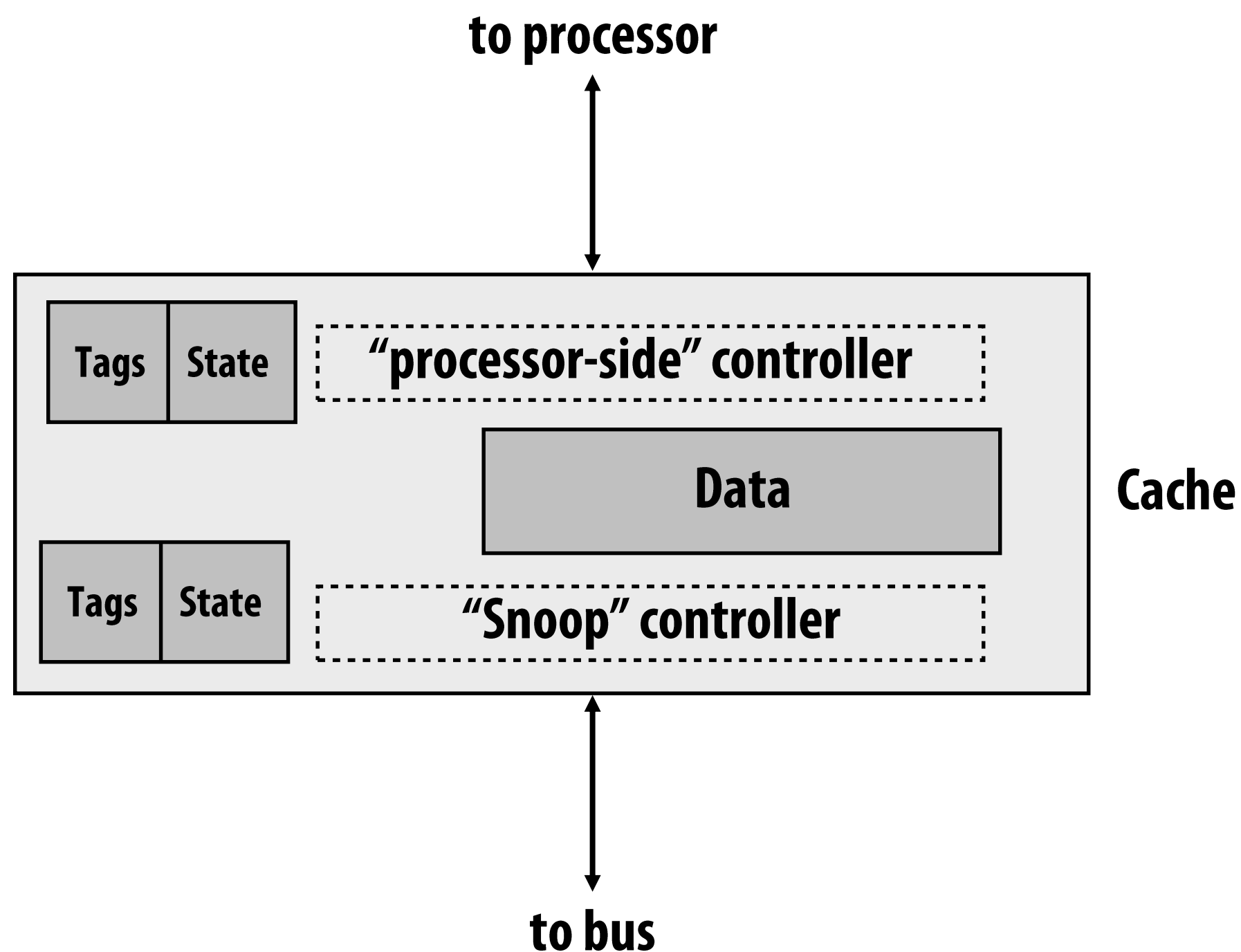

Option 1: cache **duplicate tags**

Option 2: **multi-ported** tag memory

**Note: tags must stay in sync for correctness, so tag update by one controller will still need to block the other controller (but modifying tags is infrequent compared to checking them)**

**Keep in mind: in either case cost of the additional performance is additional hardware resources.**

# Reporting snoop results protocol in MESI

- Assume a cache read miss (BusRd)
- **Collective response of caches must appear on bus**
  - Is line **dirty**? If so, memory should not respond
  - Is line **shared**? If so, cache should load into S state, not E

Memory needs to know what to do



Loading cache needs to know what to do



**How are snoop results communicated?**

**When are snoop results communicated?**

# Reporting snoop results: **how**

Bus

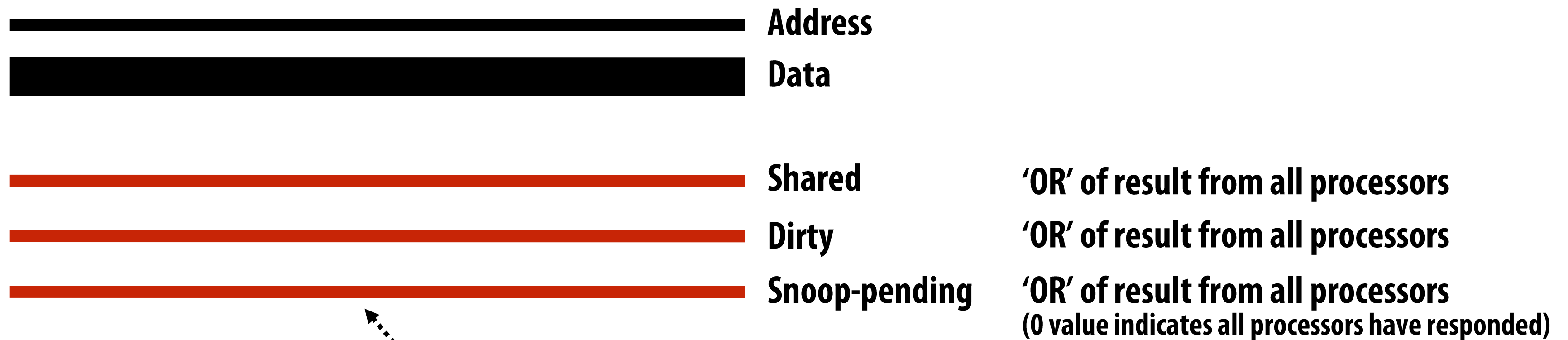

These three lines are additional  
bus interconnect hardware!

# Reporting snoop results: **when**

- Memory controller could **immediately start accessing DRAM**, but not respond (squelch response) if a snoop result from another cache indicates it has copy of most recent data
  - Cache should provide data, not memory
- Memory could **assume one of the caches will service request** until snoop results are valid (if snoop indicates no cache has data, then memory must respond)



# Handling write backs

- **Write backs involve two bus transactions**
  1. **Incoming line (line requested by processor)**
  2. **Outgoing line (evicted dirty line in cache that must be flushed)**
- **Ideally would like the processor to continue as soon as possible (it shouldn't have to wait for the flush to complete)**
- **Solution: write-back buffer**
  - **Stick line to be flushed in a write-back buffer**
  - **Immediately load requested line (allows processor to continue)**
  - **Flush contents of write-back buffer at a later time**

# Cache with write-back buffer

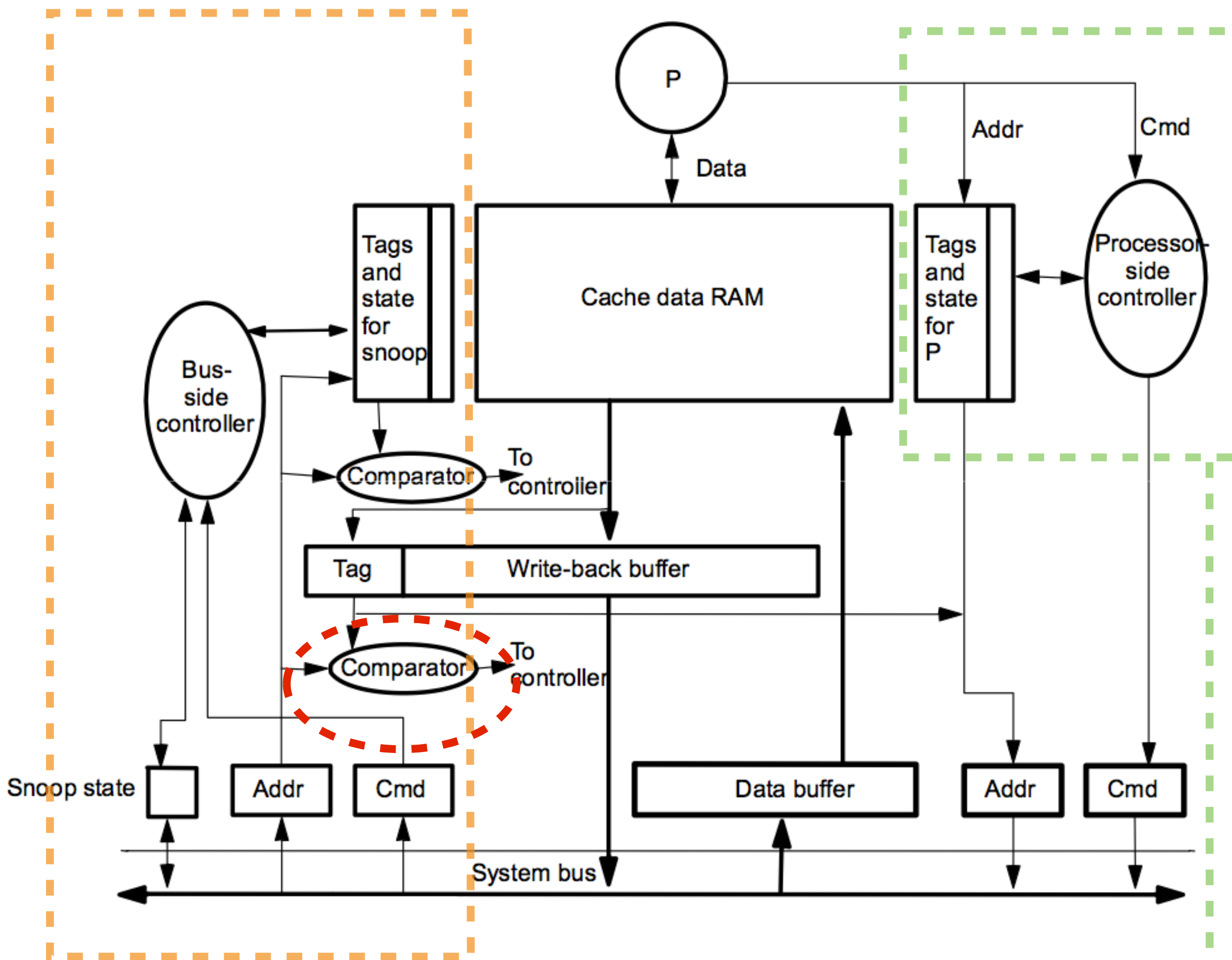

**What if a request for the address of the data in the write-back buffer appears on the bus?**

**Snoop controller must check the write-back buffer addresses in addition to cache tags.**

**If there is a write-back buffer match:**

- 1. Respond with data from write-back buffer rather than cache**
- 2. Cancel outstanding bus access request (for the write back)**

**these hardware components handle snoop related tasks**

**these hardware components handle processor-related requests**

# In practice state transitions are **not atomic**

- Coherence protocol state transition diagrams (like the one below) assumed that transitions between states were atomic
- We've assumed the bus transaction itself is atomic, but all the operations the system performs as a result of a memory operation are not
  - e.g., look up tags, arbitrate for bus, wait for actions by other controllers, ...
- Implementations must be careful to handle race conditions appropriately

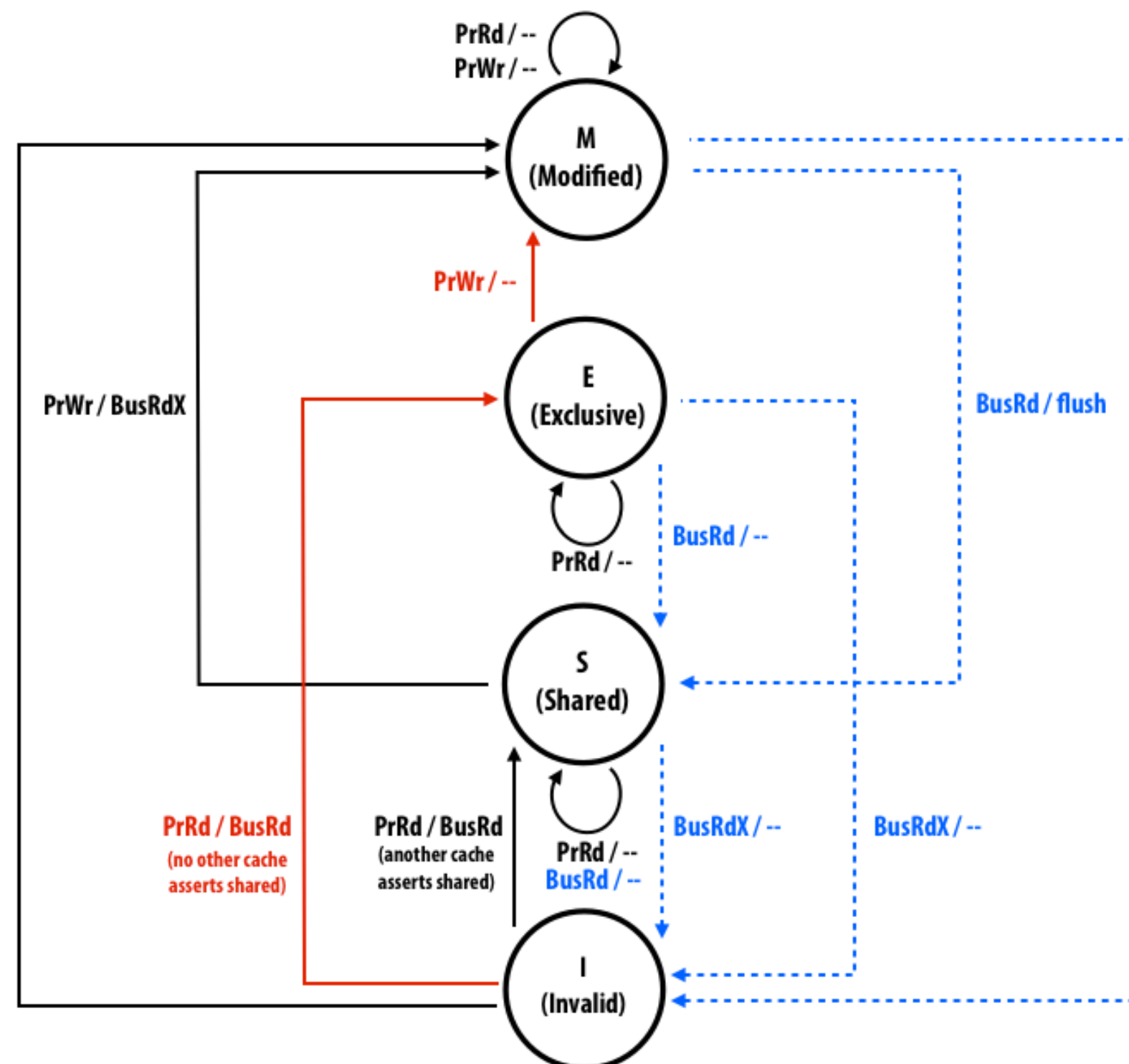

# An example race condition

Processors **P1 and P2 write to valid** (and shared) **cache line A simultaneously**  
(both need to issue BusUpg to move line from S state to M state)

P1 “wins” bus access (as determined by arbiter), P1 sends BusUpg

P2 is waiting for bus access (to send its own BusUpg), can’t proceed because P1 has bus

P2 receives BusUpg, must invalidate line A (as per MESI protocol)

*P2 must also change its pending BusUpg request to a BusRdX*



Cache must be able to handle requests while waiting to acquire bus AND be able to modify its own outstanding requests

# Fetch deadlock

**P1 has a modified copy of cache line B**

**P1 is waiting for the bus so it can issue BusRdX on cache line A**

**BusRd for B appears on bus while P1 is waiting**

***To avoid deadlock, P1 must be able to service incoming transactions while waiting to issue requests***

# Livelock

**Two processors writing to cache line B**

**P1 acquires bus, issues BusRdX**

**P2 invalidates**

**Before P1 performs cache line update, P2 acquires bus, issues BusRdX**

**P1 invalidates**

**and so on...**

***To avoid livelock, a write that obtains exclusive ownership must be allowed to complete before exclusive ownership is relinquished.***

# Self check: when does a write “commit?”

- A write commits when a **read-exclusive transaction appears on bus and is acknowledged by all other caches**
  - **At this point, the write is “committed”**
  - **All future reads will reflect the value of this write (even if data from P has not yet been written to P’s dirty cache line, or to memory)**
  - **Key idea: order of transactions on the bus defines the global order of writes in the parallel program (write serialization)**
- **Commit != complete: a write completes when the updated value is in the cache line**
- **Why does a write-back buffer not effect time of commit?**

# Starvation

- **Multiple processors competing for bus access**
  - Must be careful to avoid (or minimize likelihood of) starvation
  - E.g., what if processor with “lowest id” wins.
  
- **Example policies that achieve greater fairness:**
  - FIFO arbitration
  - Priority-based heuristics (frequent bus users have priority drop)



# Design issues

- **Design of cache controller and tags**  
(to support access from processor and bus)
- **How and when to present snoop results on bus**
- **Dealing with write backs**
- **Dealing with non-atomic state transitions**
  
- **Avoiding deadlock, livelock, starvation**

*These issues arose even though we only implemented a few optimizations on a very basic invalidation-based, write-back system!*

*(atomic bus, one outstanding memory request per processor, single-level caches)*

# First-half summary: parallelism and concurrency in coherence implementation are sources of complexity

- **Processor, cache, and bus all are resources operating in parallel**
  - Often contending for shared resources:
    - Processor and bus contend for cache
    - Caches contend for bus access
- “Memory operations” that are **abstracted** by the architecture as atomic (e.g., loads, stores) are **implemented** via multiple transactions involving all of these hardware components
- Performance optimization often entails **splitting operations into several, smaller transactions**
  - Splitting work into smaller transactions reveals more parallelism (recall pipelining)
  - Cost: more hardware needed to exploit additional parallelism
  - Cost: care needed to ensure abstractions still hold (the machine is correct)

# **Part 2:**

## **Building the system around non-atomic bus transactions**

# What you should know

- **What is the major performance issue with atomic bus transactions that motivates moving to a more complex non-atomic system?**
- **You should know the main components of a split-transaction bus, and how transactions are split into requests and responses**
- **The role of queues in a parallel system (today is yet another example)**

# Review: transaction on an atomic bus

1. Client is granted bus access (result of arbitration)
2. Client places command on bus (may also place data on bus)



Problem: **bus is idle while response is pending**  
(this decreases effective bus bandwidth)

This is bad, because the interconnect is a limited, shared resource in a multi-processor system.

**(So it is important to use it as efficiently as possible)**

3. Response to command by another bus client placed on bus
4. Next client obtains bus access (arbitration)

# Split-transaction bus

Bus transactions are **split into two transactions**:

1. The request
2. The response

Other transactions can intervene between a transaction's request and response.

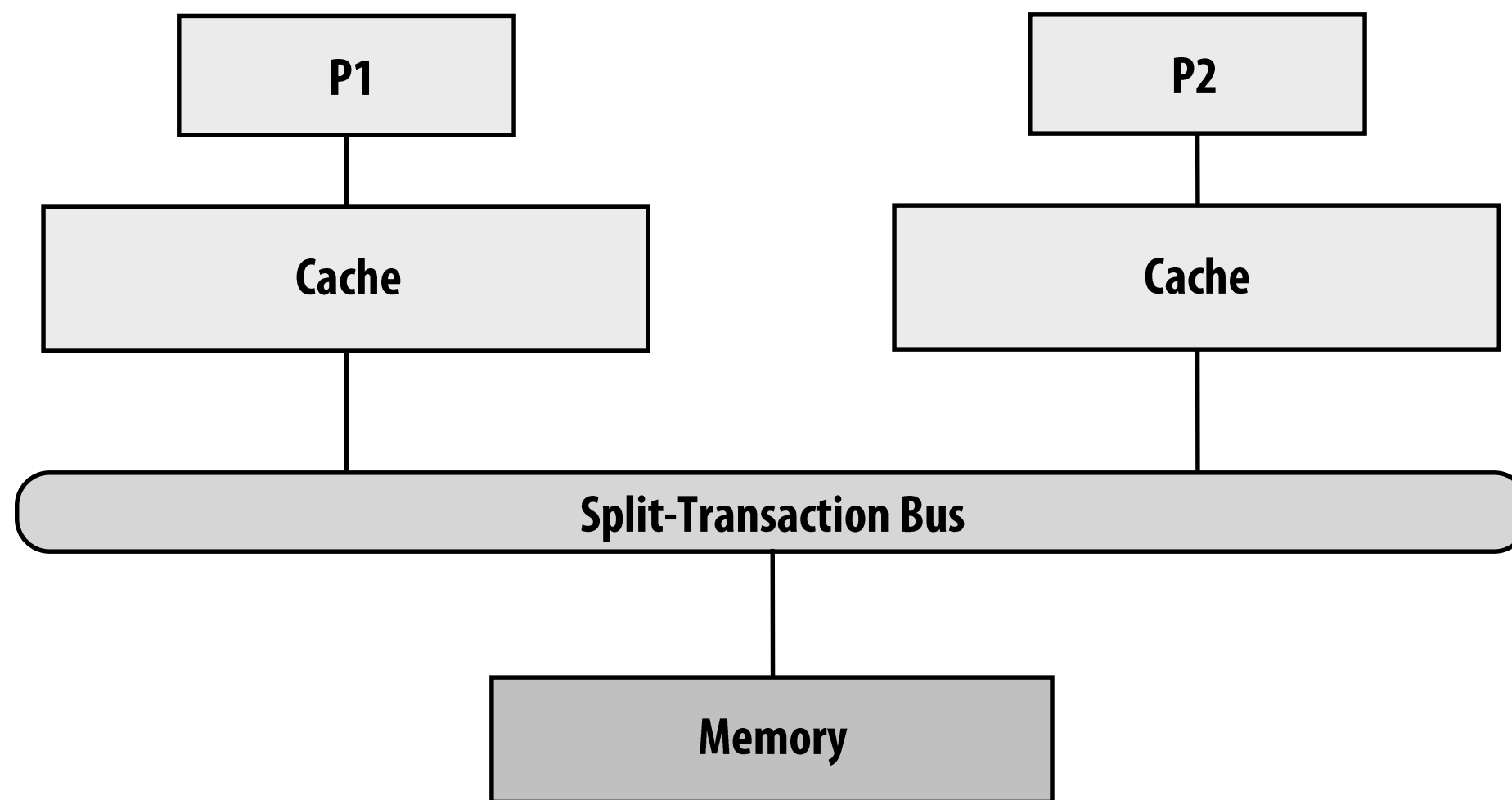

Consider this scenario:

Read miss to A by P1

Bus upgrade of B by P2

---

Possible timeline of events on a split-transaction bus:

P1 gains access to bus

P1 sends BusRd command

[memory starts fetching data now...]

P2 gains access to bus

P2 sends BusUpg command

Memory gains access to bus

Memory places A on bus

# New issues arise due to split transactions

1. How to **match requests with responses**?
2. How to handle **conflicting requests** on bus? Consider:
  - P1 has outstanding request for line A
  - Before response to P1 occurs, P2 makes request for line A
3. **Flow control**: how many requests can be outstanding at a time, and what should be done when buffers fill up?
4. **When are snoop results reported**? During the request? or during the response?

# A basic design

- **Up to eight outstanding requests at a time (system wide)**
- **Responses need not occur in the same order as requests**
  - But request order establishes the total order for the system
- **Flow control via negative acknowledgements (NACKs)**
  - When a buffer is full, client can NACK a transaction, causing a retry



# Initiating a request

Can **think** of a split-transaction bus as **two separate buses**:  
a request bus and a response bus.

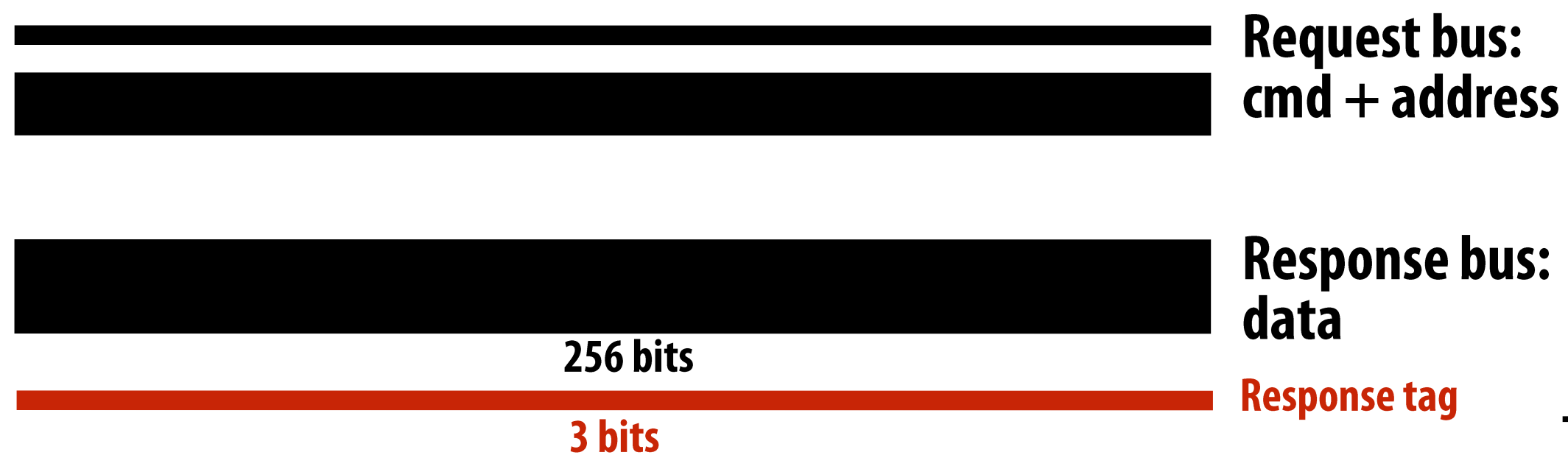

**Request Table**  
(assume a copy of this table is maintained by each bus client: e.g., cache)

Transaction tag is just the index into the request table

Requestor	Addr	State
P0	0xbeef	

**Step 1: Requestor asks for request bus access**

**Step 2: Bus arbiter grants access, assigns transaction a tag**

**Step 3: Requestor places command + address on the request bus**

# Read miss: cycle-by-cycle bus behavior (phase 1)

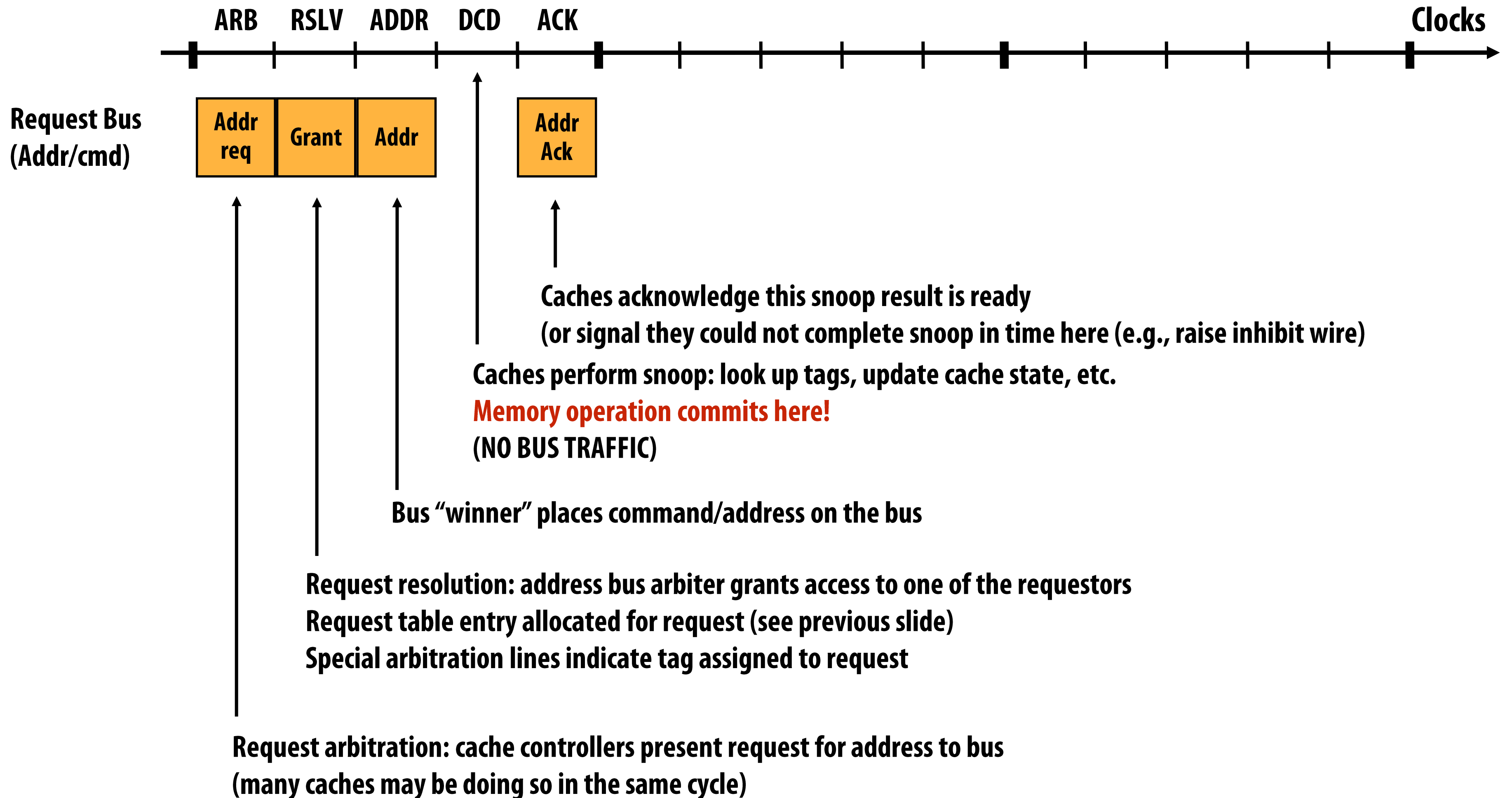

# Read miss: cycle-by-cycle bus behavior (phase 2)

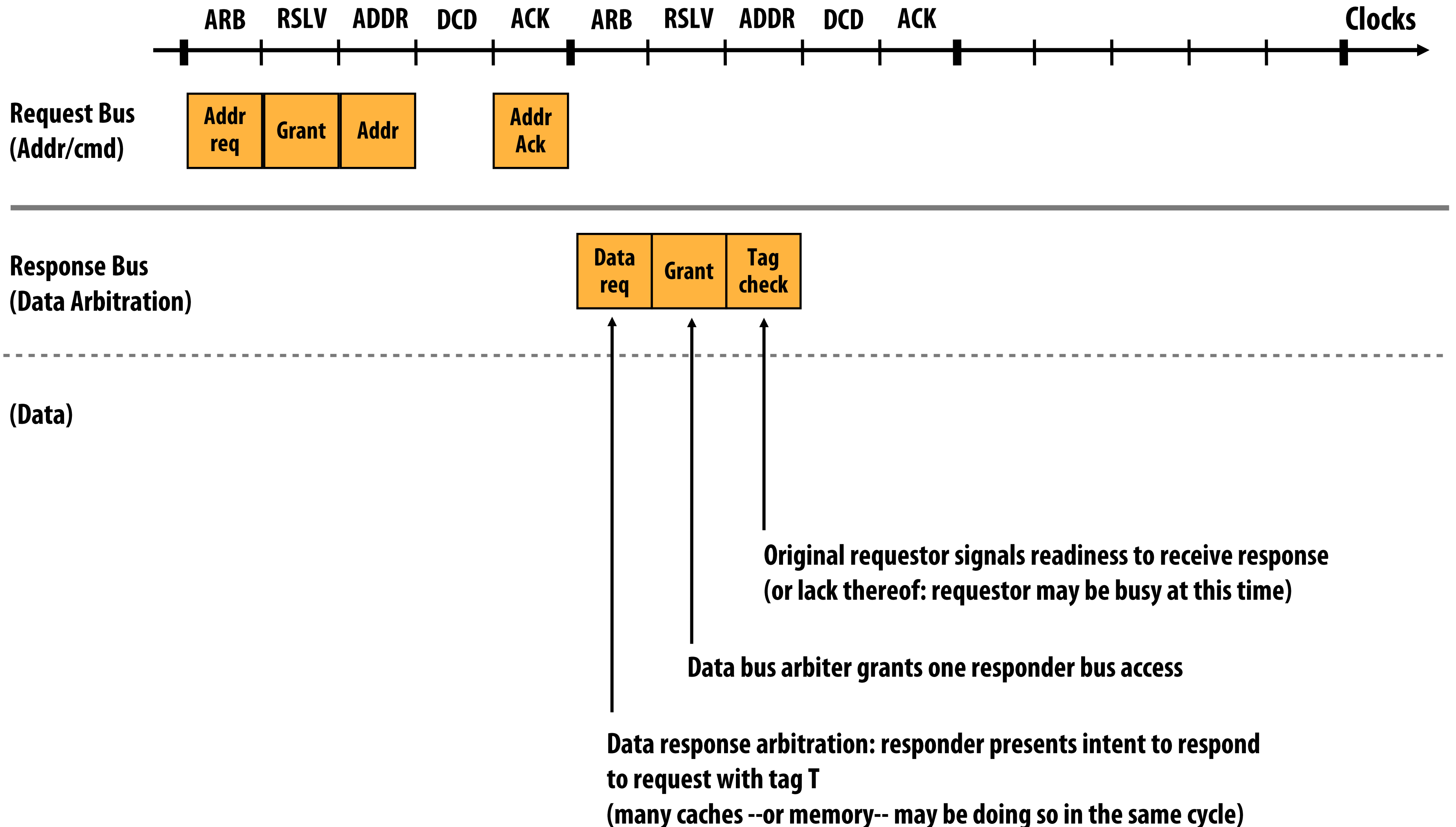

# Read miss: cycle-by-cycle bus behavior (phase 3)

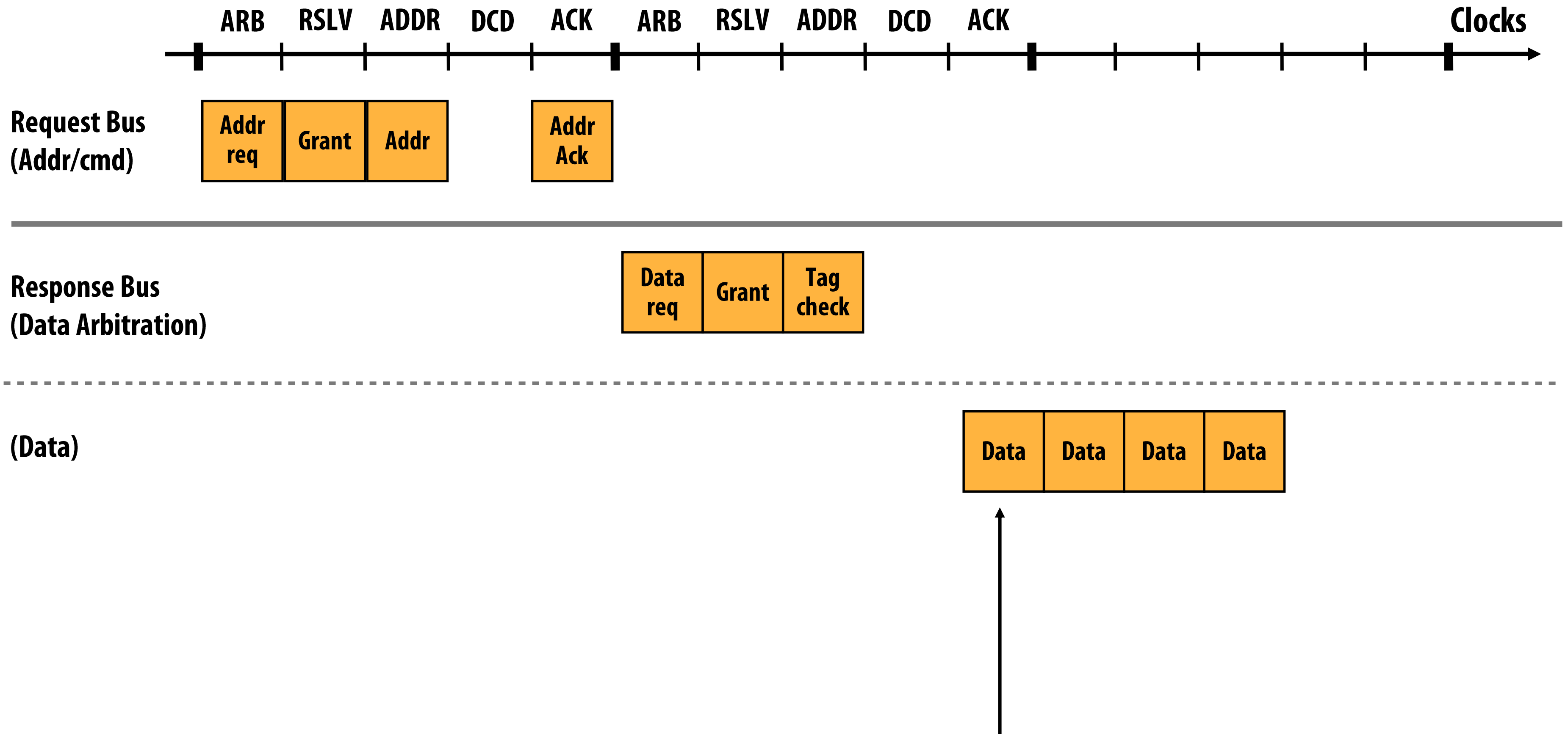

Responder places response data on data bus  
Caches present snoop result for request with the data  
Request table entry is freed  
Here: assume 128 byte cache lines → 4 cycles on 256 bit bus

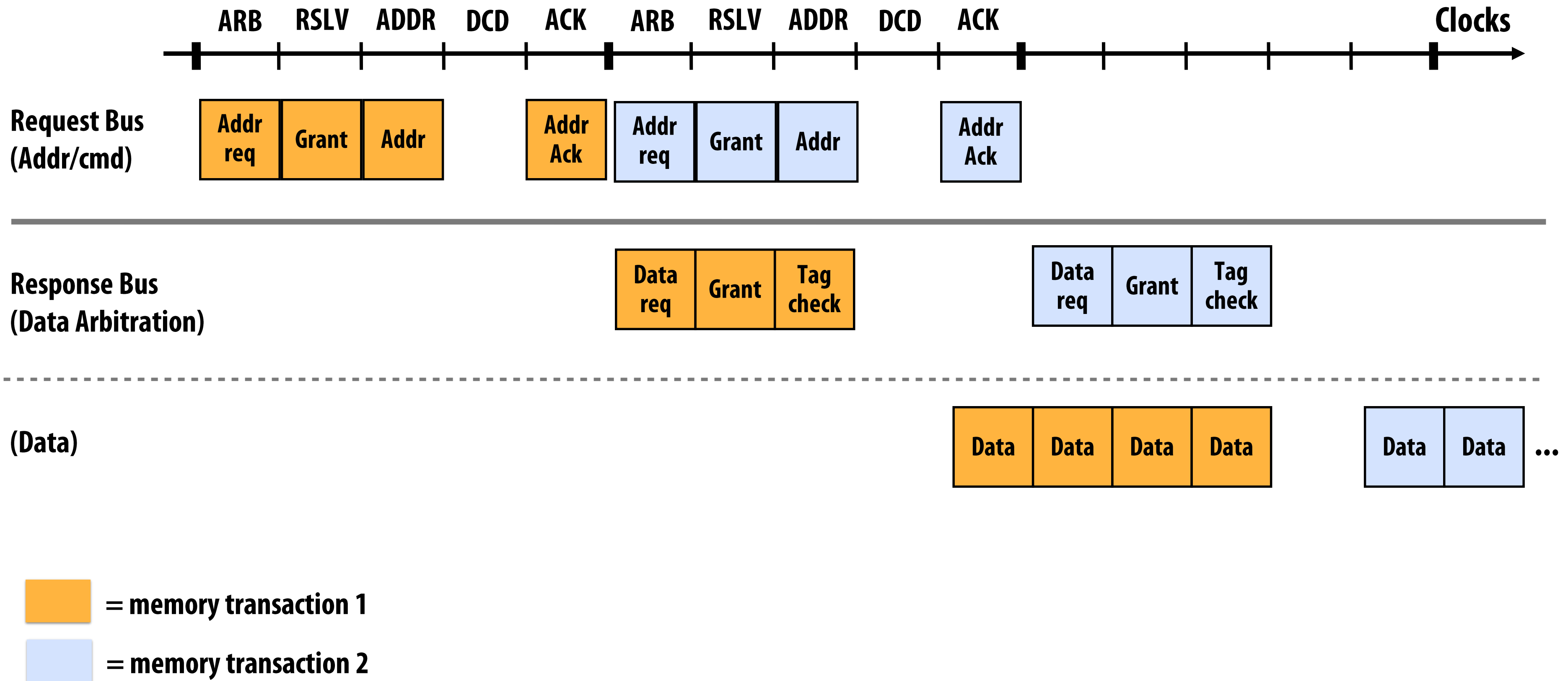

# Pipelined transactions

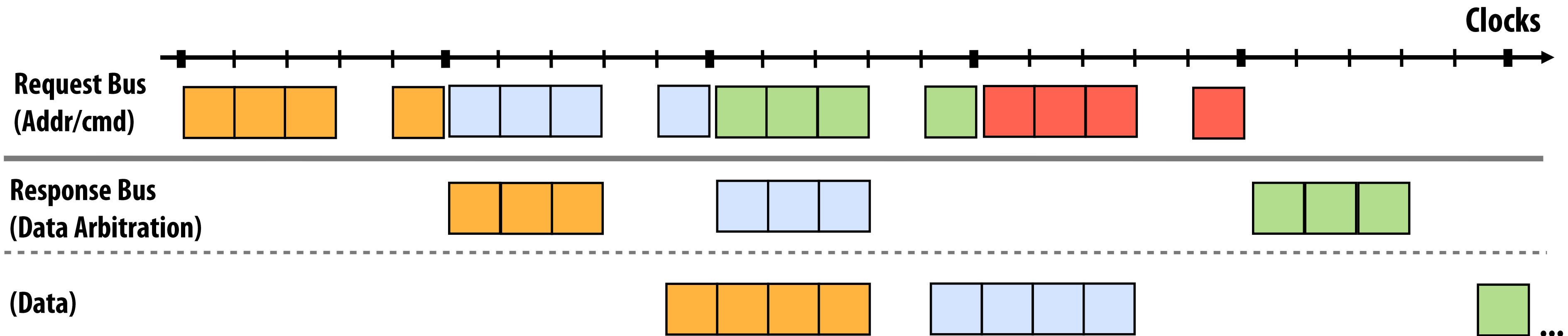

**Note: write backs and BusUpg transactions do not have a response component (write backs acquire access to both request address bus and data bus as part of “request” phase)**

# Pipelined transactions

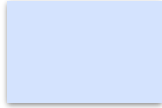
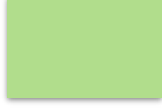

-  = memory transaction 1
-  = memory transaction 2
-  = memory transaction 3
-  = memory transaction 4

Note **out-of-order completion**.

# Key issues to resolve

## ■ **Conflicting requests**

- **Avoid conflicting requests by disallowing them**
- **Each cache has a copy of the request table**
- **Simple policy: caches do not make requests that conflict with requests in the request table**

## ■ **Flow control:**

- **Caches/memory have buffers for receiving data off the bus**
- **If the buffer fills, client NACKs relevant requests or responses (NACK = negative acknowledgement)**
- **Triggers a later retry**

# Situation 1: P1 read miss to X, read transaction involving X is outstanding on bus

P1 Request Table

Requestor	Addr	State
P2	X	Op: BusRd , share

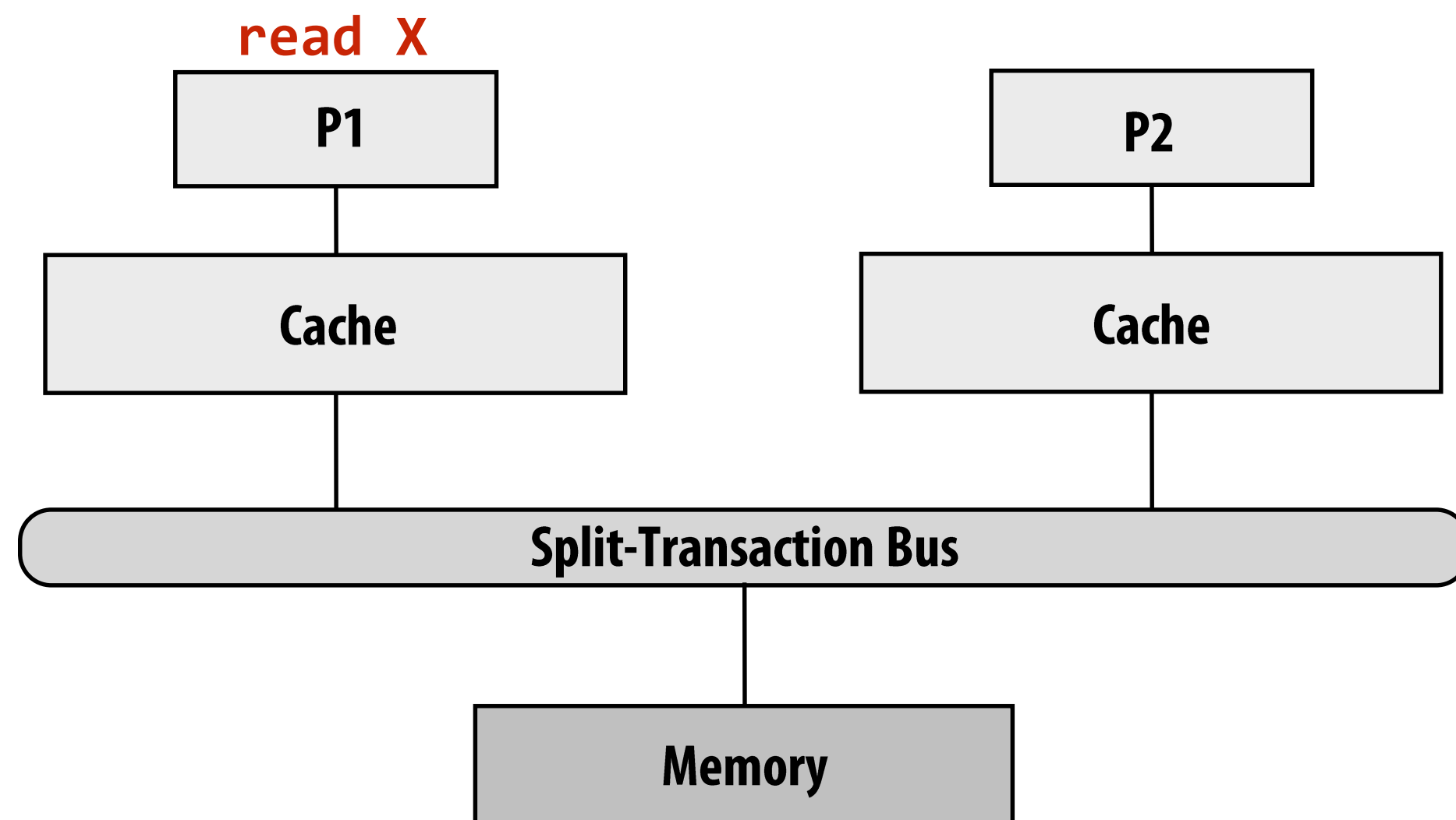

If **outstanding request** is a read: there is no conflict. No need to make a new bus request, just listen for the response to the outstanding one.



# Situation 2: P1 read miss to X, write transaction involving X is outstanding on bus

P1 Request Table

Requestor	Addr	State
P2	X	Op: BusRdX

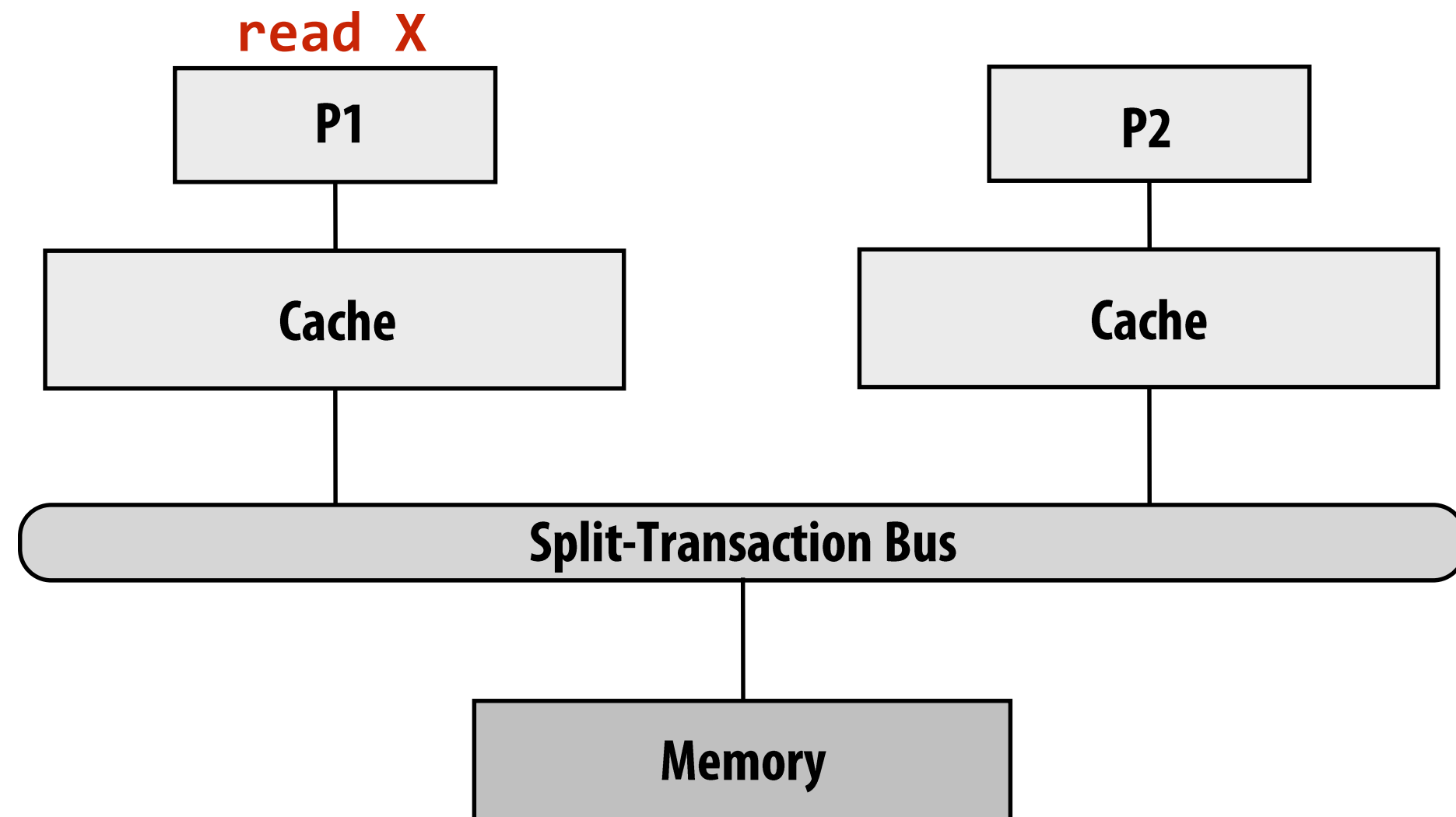

If there is a conflicting outstanding request (as determined by checking the request table), **cache must hold request** until conflict clears

# Why do we have queues in a parallel system?

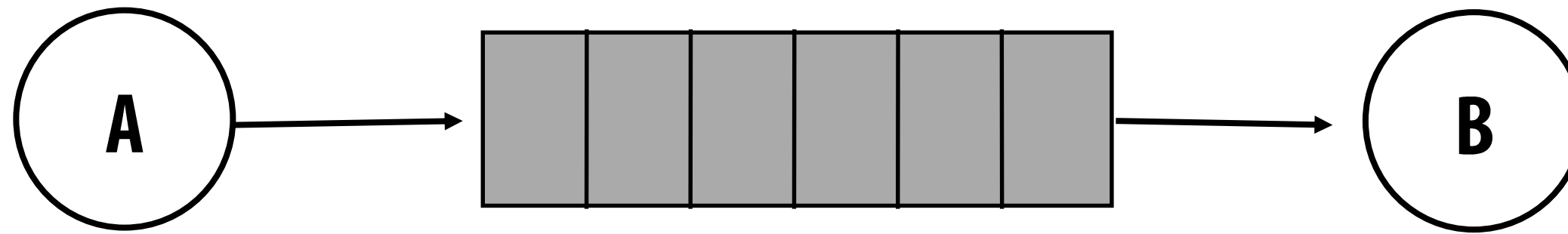

**Answer: to accommodate variable (unpredictable) rates of production and consumption. As long as A and B, on average, produce and consume at the same rate, both workers can run at full rate.**

**No queue: notice A stalls waiting for B to accept new input (and B sometimes stalls waiting for A to produce new input).**

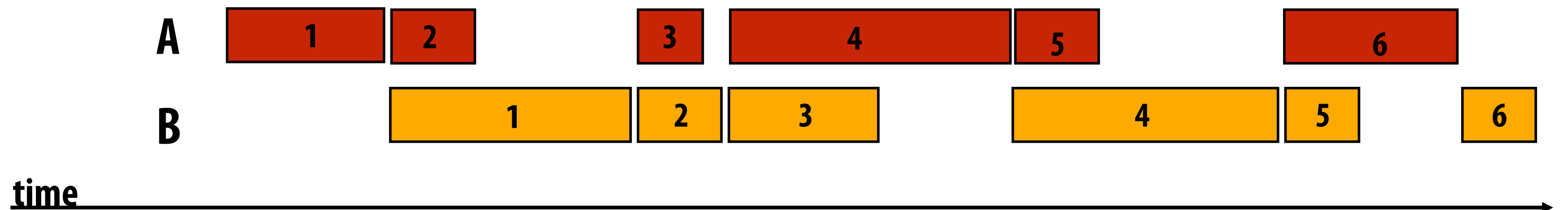

**With queue of size 2: A and B never stall**

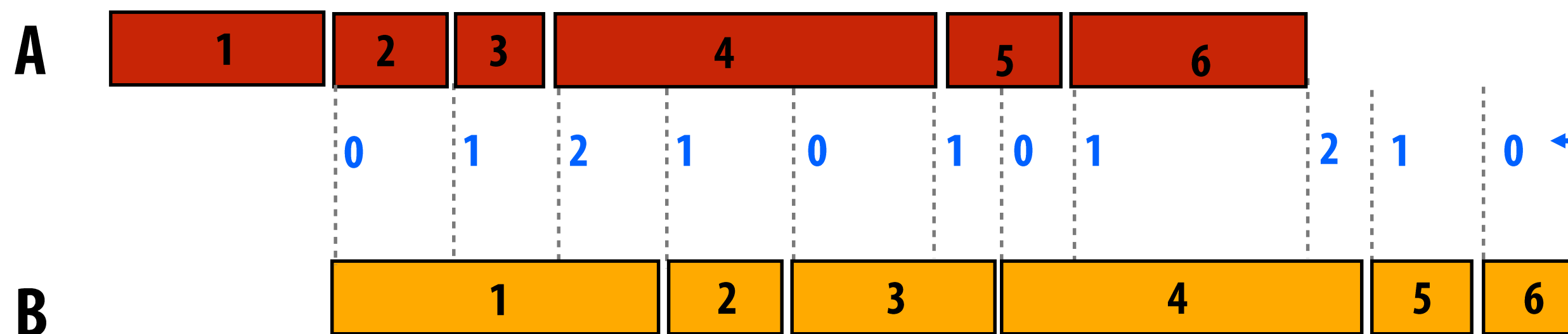

Size of queue when A completes a piece of work (or B begins work)

# Multi-level cache hierarchies

Numbers indicate steps in a cache miss from processor on left. Serviced by cache on right.

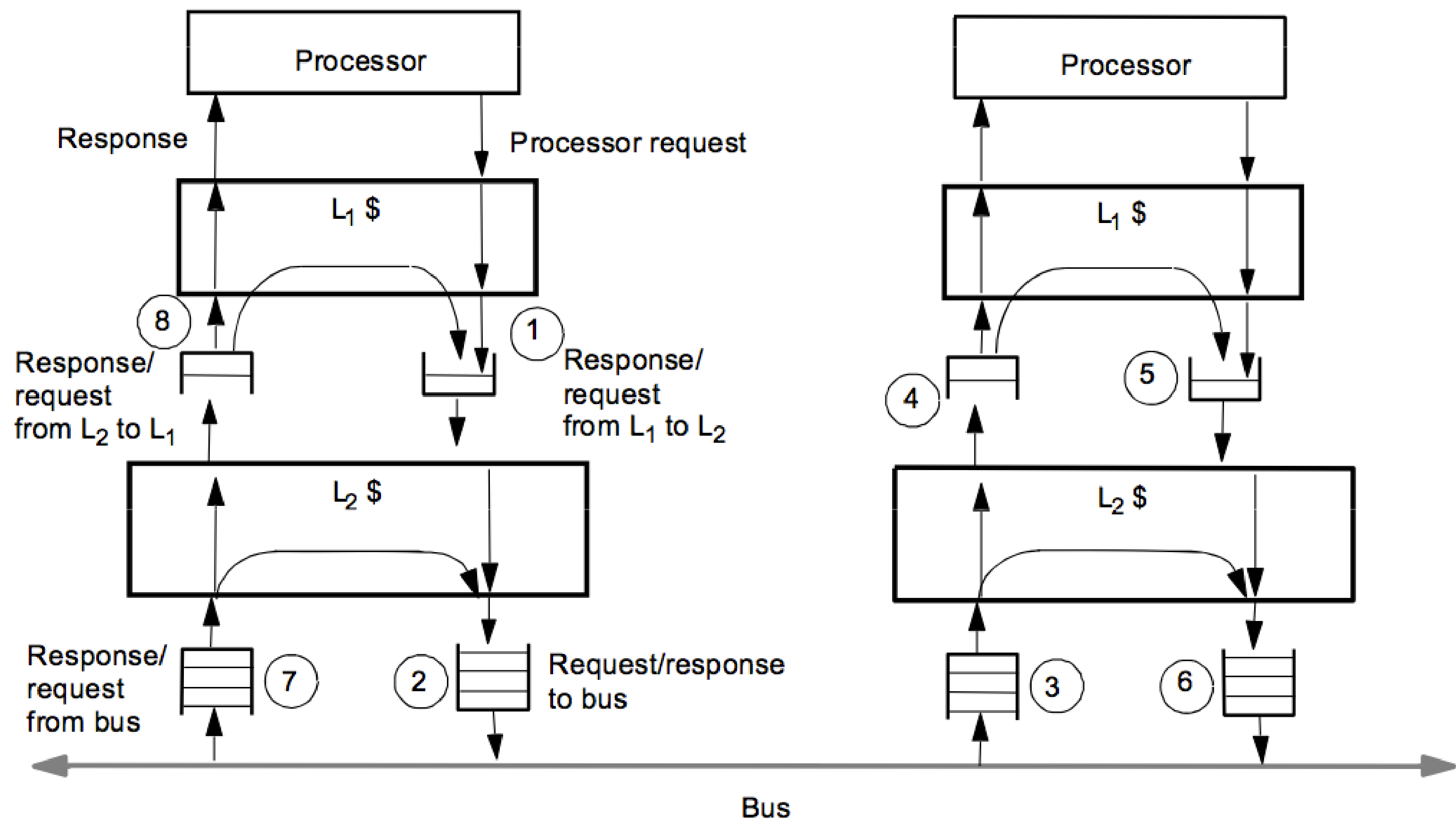

# Recall the **fetch-deadlock** problem

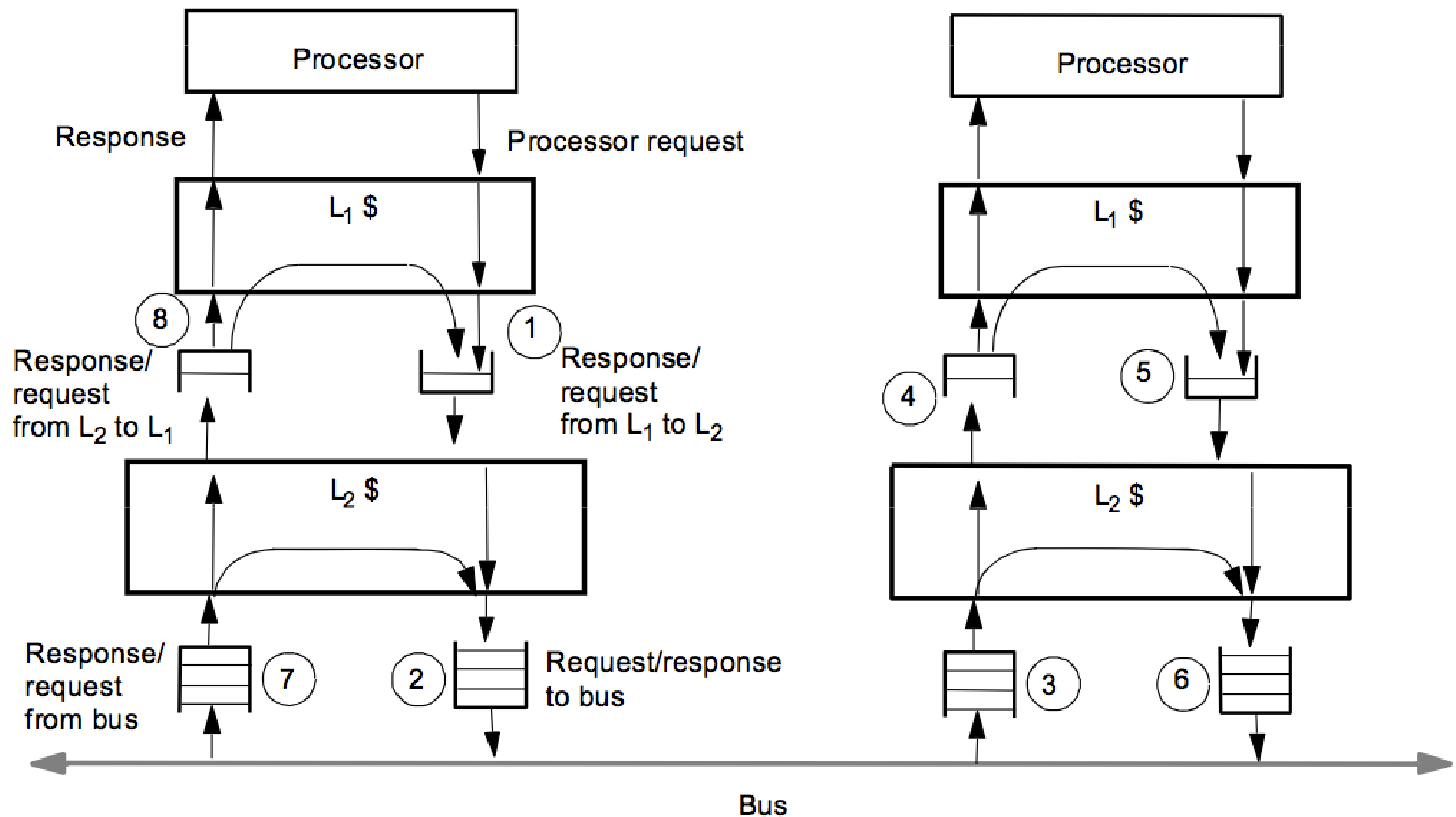

**Assume one outstanding memory request per processor.**

**Consider fetch-deadlock problem: cache must be able to service requests while waiting on response to its own request (hierarchies increase response delay)**

# Deadlock due to full queues

Assume buffers are sized so that the maximum queue size is one message. (buffer size = 1)

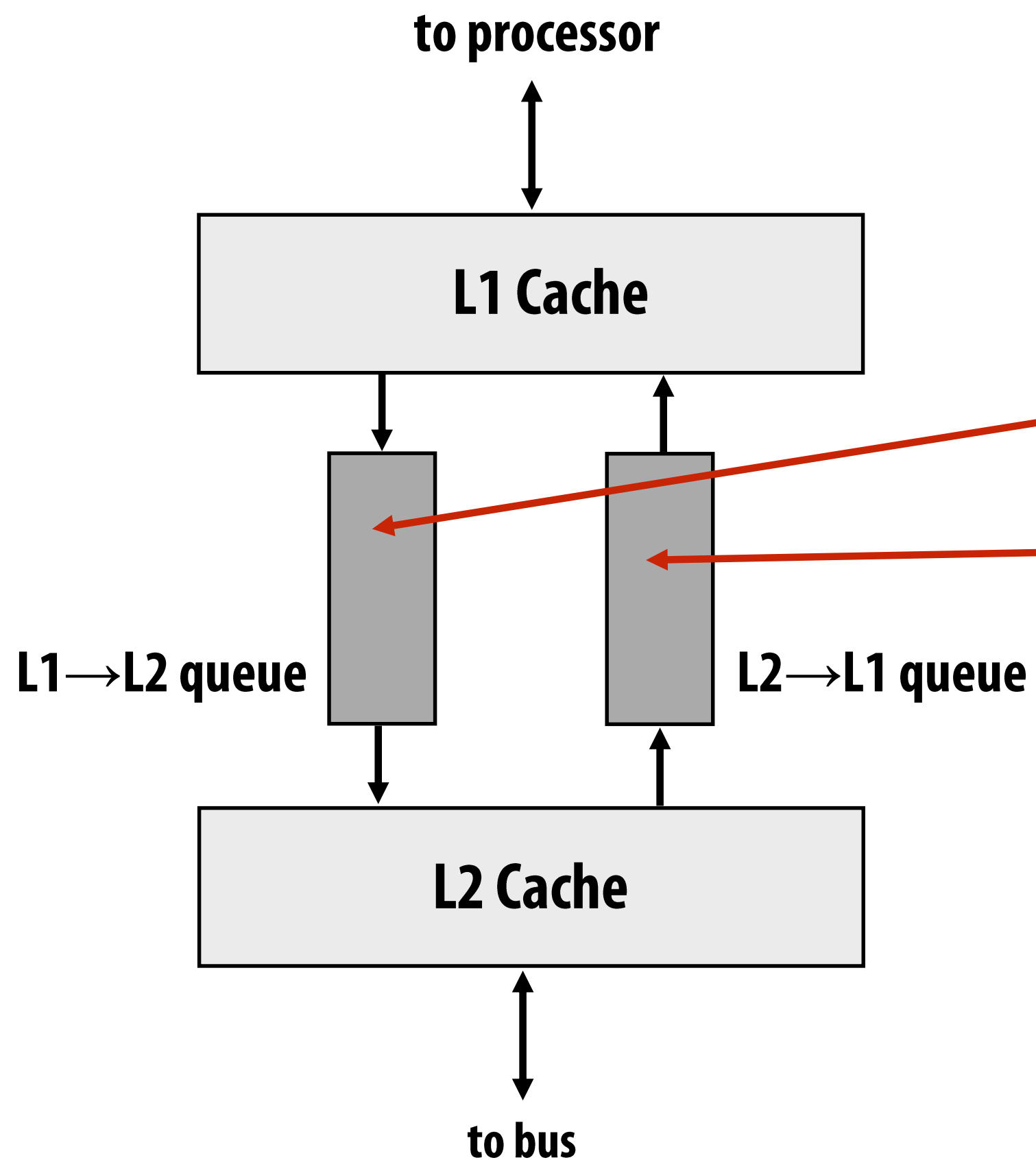

Outgoing read request (initiated by processor)

Incoming read request (due to another cache) \*\*

Both requests generate responses that require space in the other queue (circular dependency)

\*\* will only occur if L1 is write back

# Multi-level cache hierarchies

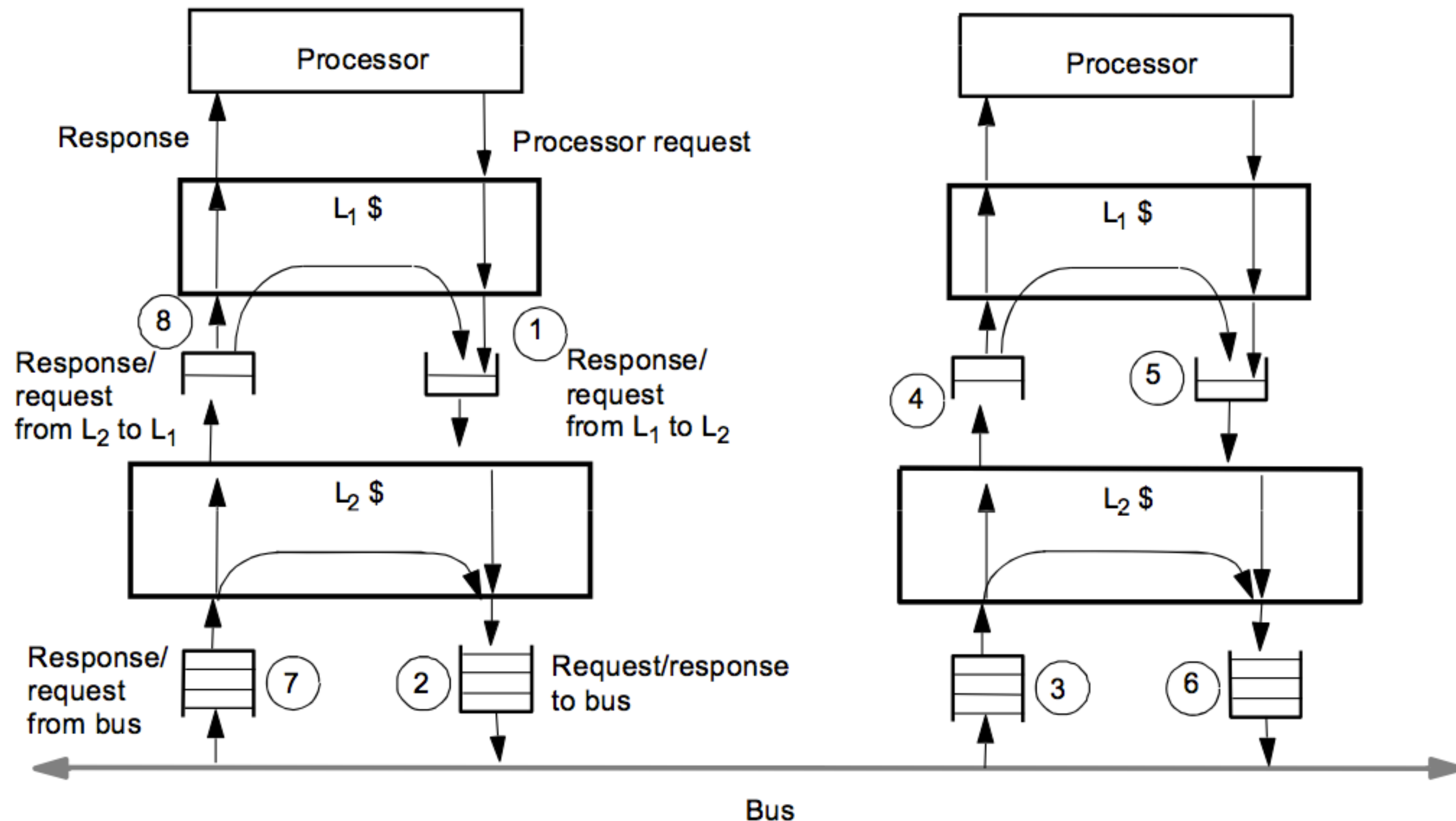

Assume one outstanding memory request per processor.

Consider fetch deadlock problem: cache must be able to service requests while waiting on response to its own request (hierarchies increase response delay)

**Sizing all buffers to accommodate the maximum number of outstanding requests on bus is one solution to avoiding deadlock. But a costly one!**

# Avoiding buffer deadlock with **separate request/response queues**

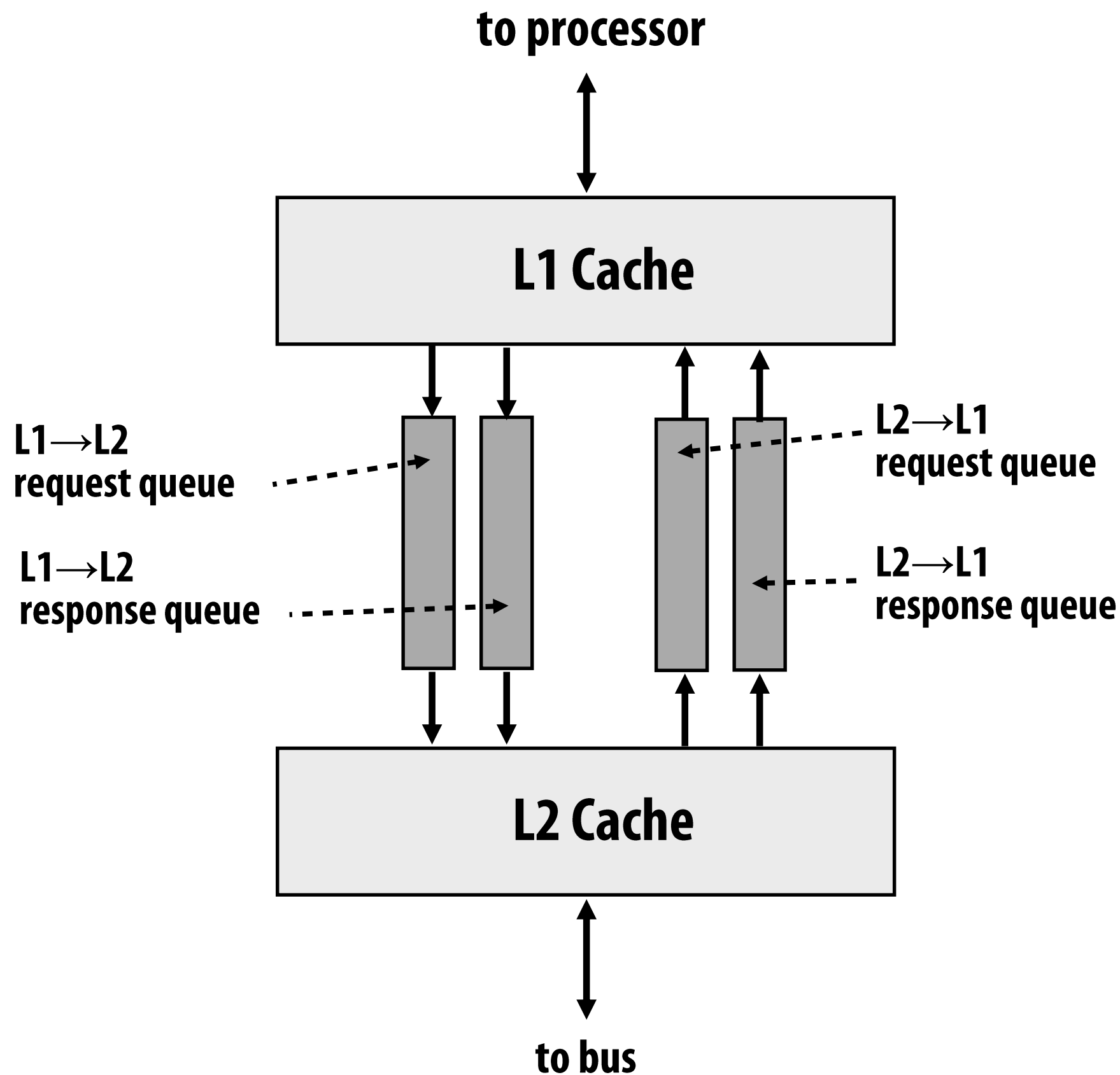

System classifies all transactions as requests or responses

Key insight: **responses can be completed without generating further transactions!**

**Requests INCREASE queue length**  
**But responses REDUCE queue length**

While stalled attempting to send a request, cache must be able to service responses.

**Responses will make progress** (they generate no new work so there's no circular dependence), eventually freeing up resources for requests

# Putting it all together

**Class exercise: describe everything that might occur during the execution of this statement**

```
int x = 10;           // assume this is a write to memory (the value  
                        // is not stored in register)
```



# Class exercise: describe everything that might occur during the execution of this statement \*

```
int x = 10;
```

**\* This list is certainly not complete, it's just what I came up with off the top of my head. (This would be a great job interview question!)**

1. Virtual address to physical address conversion (TLB lookup)
2. TLB miss
3. TLB update (might involve OS)
4. OS may need to swap in page to get the appropriate page table (load from disk to physical address)
5. Cache lookup (tag check)
6. Determine line not in cache (need to generate BusRdX)
7. Arbitrate for bus
8. Win bus, place address, command on bus
9. All caches perform snoop (e.g., invalidate their local copies of the relevant line)
10. Another cache or memory decides it must respond (let's assume it's memory)
11. Memory request sent to memory controller
12. Memory controller is itself a scheduler
13. Memory controller checks active row in DRAM row buffer. (May need to activate new DRAM row. Let's assume it does.)
14. DRAM reads values into row buffer
15. Memory arbitrates for data bus
16. Memory wins bus
17. Memory puts data on bus
18. Requesting cache grabs data, updates cache line and tags, moves line into exclusive state
19. Processor is notified data exists
20. Instruction proceeds