

Exploiting Weak Connectivity in a Distributed File System

Lily B. Mummert

December 1996

CMU-CS-96-195

School of Computer Science
Computer Science Division
Carnegie Mellon University
Pittsburgh, PA

*Submitted in partial fulfillment of the requirements
for the degree of Doctor of Philosophy.*

Thesis Committee:

Mahadev Satyanarayanan, Chair

Garth Gibson

James Morris

Patrick Mitchell, Intel Corporation

Copyright © 1996 Lily B. Mummert

This research was sponsored by the Air Force Materiel Command (AFMC) and the Defense Advanced Research Projects Agency (DARPA) under contract number F19628-93-C-0193. Additional support was provided by the IBM Corporation, Digital Equipment Corporation, and Intel Corporation.

The views and conclusions contained in this document are those of the authors and should not be interpreted as necessarily representing the official policies or endorsements, either expressed or implied, of the AFMC, DARPA, DEC, IBM, Intel, or the U. S. Government.

Keywords: Distributed file systems, weak connectivity, high availability, mobile computing, Coda, reintegration, application-transparent adaptation, UNIX

To Todd

Abstract

Weak connectivity, in the form of intermittent, low-bandwidth, or expensive networks is a fact of life in mobile computing. For the foreseeable future, access to cheap, high-performance, reliable networks, or *strong connectivity* will be limited to a few oases, such as work or home, in a vast desert of weak connectivity. The design of distributed file systems has traditionally been based on an assumption of strong connectivity. Yet, to provide ubiquitous data access, it is vital that distributed file systems make effective use of weak connectivity.

This dissertation describes the design, implementation, and evaluation of weakly connected operation in the Coda File System. The starting point of this work is *disconnected operation*, in which a file system client operates using data in its cache during server or network failures. Disconnected clients suffer from many limitations: *updates are not visible* to other clients, *cache misses* may impede progress, *updates are at risk* from client loss or damage, and the danger of *update conflicts* increases as disconnections are prolonged. Weak connectivity provides an opportunity to alleviate these limitations.

Coda's strategy for weakly connected operation is best characterized as *application-transparent adaptation*. The system bears full responsibility for coping with the demands of weak connectivity. This approach preserves upward compatibility by allowing applications to run unchanged. Coda provides several mechanisms for weakly connected operation motivated by actual experience. The foundation of adaptivity in this system is the *communications layer*, which derives and supplies information on network conditions to higher system layers. The *rapid cache validation* mechanism enables the system to recover quickly in intermittent environments. The *trickle reintegration* mechanism insulates the user from poor network performance by propagating updates to servers asynchronously. The *cache miss handling* mechanism alerts the user to potentially lengthy service times and provides opportunities for intervention.

A quantitative evaluation of these mechanisms, based on controlled experimentation and empirical data gathered from the deployed system in everyday use, shows that Coda is able to provide good performance even when network bandwidth varies over four orders of magnitude – from modem speeds to LAN speeds.

Acknowledgements

First I would like to thank Satya. I could not have asked for a better advisor or mentor. He always made time to meet with me, despite his increasingly busy schedule, and he never failed to provide insightful feedback on my work. He was patient and encouraging when I struggled, and demanding when I needed to be challenged. Satya, working with you has been a privilege.

I'd like to thank the other members of my thesis committee, Garth Gibson, Jim Morris, and Pat Mitchell, for their feedback on the thesis. Special thanks go to Pat Mitchell, for gallantly stepping in as my outside committee member at the last minute.

I'd like to thank Jeannette Wing for patiently guiding me through my foray in protocol analysis. I could not have done that work without her. I'd also like to thank Peter Braam for providing many thoughtful insights on the analysis.

Past and present members of the Coda group provided a great deal of support: Bob Baron, Peter Braam, Maria Ebling, Jay Kistler, Puneet Kumar, Qi Lu, Hank Mashburn, Dushyanth Narayanan, Brian Noble, Josh Raiff, David Steere, and Eric Tilton. They are a very talented group of people and it has been a pleasure to work with them.

No systems project can survive without users. Thanks go to all of the Coda users for their patience and tolerance in dealing with an experimental system. I'd like to thank David Eckhardt in particular for pushing the system in ways we hadn't imagined, and for his willingness to listen to all sorts of half-baked ideas.

Many friends provided emotional support during the long process of finishing my Ph.D. They include: Jay Kistler and Chris Conklin, for making me feel welcome during the first difficult months at CMU; Joanne Karohl and Dorcie Jasperse, for providing long-distance thesis support; and Anurag Acharya, Bruce Horn, and Dave Tarditi, for creating a pleasant office environment.

I'd like to acknowledge my dogs, Tasha, Zoey, and Boo, for reminding me of the importance of a life outside of work. Gert Sullivan instructed my first dog obedience class and introduced me to dog sports. I've met many wonderful people through dog activities, and I thank them for their friendship and for many enjoyable training sessions: Ellen Berman, Annette Bush, Marty Coody, Margo Foster, Phil Gallagher, Gayle Geiger, Nancy Glabicki, Fred Hulme, Doug and

Ann Humbertson, Dorcie Jasperse, Sharon Kilrain, Barb Martin, Erin McGlynn and Harold Walls, and Libby Simendinger.

I'd like to thank my parents, Victor and Donna Barkovic, for emphasizing the importance of hard work and encouraging me to strive for excellence. Thanks to my sister Sylvia, for being a friend.

Finally, I want to thank my husband Todd, for being patient beyond all reasonable expectation. I love you.

Lily Mummert
Pittsburgh, Pennsylvania
December 1996

Contents

1	Introduction	1
1.1	Distributed File Systems	1
1.2	Disconnected Operation	2
1.3	The Thesis	3
1.3.1	Scope of Thesis	3
1.3.2	Approach	4
1.3.3	Mechanisms for Weak Connectivity	5
1.3.4	Validation of Thesis	5
1.4	Document Roadmap	6
2	Coda File System	7
2.1	Design Goals	7
2.1.1	Scalability	7
2.1.2	Performance	8
2.1.3	Security	9
2.1.4	Operability	9
2.2	Mechanisms for High Availability	9
2.2.1	Server Replication	10
2.2.2	Disconnected Operation	12
2.3	Client Overview	24
2.4	Server Overview	24

3	Communication Layer Adaptation	27
3.1	Design Alternatives	28
3.2	Remote Procedure Call	29
3.2.1	Protocol Overview	29
3.2.2	Retransmission Strategy	30
3.2.3	Sharing Liveness Information	35
3.3	Bulk Data Transfer	36
3.3.1	Protocol Overview	36
3.3.2	Obtaining RTT Observations	39
3.3.3	Estimating RTT	41
3.3.4	Retransmission Strategy	41
3.4	Exporting Network Information	42
3.4.1	Liveness	43
3.4.2	Transmission Logs	44
3.4.3	Application Uses	49
3.5	Effects of Server Replication	51
3.5.1	MultiRPC	51
3.5.2	Connectivity to an AVSG	52
3.6	Quality of Service	52
3.7	Chapter Summary	53
4	Rapid Cache Validation	55
4.1	Design	56
4.1.1	Choice of Granularity	56
4.1.2	Volume Callbacks	57
4.2	Protocol Description	57
4.2.1	Obtaining Callbacks	58
4.2.2	Handling Callback Breaks	58
4.3	Implementation Details	61
4.3.1	Server Modifications	61

<i>CONTENTS</i>	xi
4.3.2 VCB Acquisition Policy	63
4.3.3 Access Rights	64
4.3.4 Effects of Replication	65
4.3.5 VCB Maintenance and Updates	66
4.4 Correctness	66
4.4.1 General Approach	67
4.4.2 Benefits of Formal Analysis	67
4.5 Chapter Summary	68
5 Trickle Reintegration	69
5.1 Relationship to Write-Back Caching	69
5.2 Architecture	70
5.2.1 Structural Modifications	71
5.2.2 Preserving the Effectiveness of Log Optimizations	72
5.2.3 Overview of the Algorithm	73
5.3 Detailed Design	79
5.3.1 Concurrency Control	79
5.3.2 Reducing the Impact of Reintegration	83
5.3.3 Remote Updates and Volume Callbacks	85
5.3.4 Ensuring Atomicity	87
5.3.5 Effects of Server Replication	89
5.4 Selecting an Aging Window	92
5.4.1 File Reference Traces	92
5.4.2 Venus Simulator	96
5.4.3 Results	96
5.5 Chapter Summary	106

6	Handling Cache Misses	113
6.1	Advice Monitor	114
6.2	User Interactions	115
6.2.1	Handling Cache Misses	115
6.2.2	Augmenting the HDB	116
6.2.3	Controlling Hoard Walks	119
6.3	Patience Model	119
6.4	Chapter Summary	121
7	Evaluation	123
7.1	Evolution and Implementation Status	123
7.2	Usage Environment	124
7.3	Transport Protocol	125
7.4	Rapid Cache Validation	127
7.4.1	Performance Under Ideal Conditions	128
7.4.2	Use in Practice	136
7.5	Trickle Reintegration	143
7.5.1	Methodology: Trace Replay	144
7.5.2	Results	145
7.6	Chapter Summary	157
8	Related Work	159
8.1	Systems that Exploit Weak Connectivity	159
8.1.1	Distributed File Systems	159
8.1.2	Databases	161
8.1.3	Read Only Systems	162
8.1.4	Application-Specific Approaches	163
8.2	Mechanisms for Weak Connectivity	164
8.2.1	Communications	165
8.2.2	Rapid Cache Validation	165
8.2.3	Trickle Reintegration	166

9	Conclusion	167
9.1	Contributions	167
9.2	Future Work	169
9.2.1	Refinements for Weakly Connected Operation	170
9.2.2	Incorporating Monetary Cost	170
9.2.3	Improving Effectiveness and Usability of Hoarding	170
9.2.4	Exploiting Reserved Network Services	171
9.2.5	Application-Level Logging	171
9.2.6	Application-Aware Adaptation	172
9.3	Closing Remarks	173
A	Protocol Analysis	175
A.1	System Model	175
A.2	Logic	176
A.3	Goal of Cache Coherence	179
A.4	Protocol Analysis	179
A.4.1	Cache miss, no failures	183
A.4.2	Successful validation, no failures	185
A.4.3	Cache miss, followed by failure	186
A.4.4	Successful validation, failure	187
A.4.5	Failed validation	187
A.4.6	Volume miss, no failures	188
A.4.7	Volume miss, failure	191
A.4.8	Volume validation, failure	191
A.4.9	Volume validation, no failures	192
A.4.10	Other validations	194
A.5	Time-Bounded Correctness	195
A.6	Classifying Beliefs	197
A.7	Extensions	197

B	Coda Internals	199
B.1	Client Structure	199
B.1.1	Coda MiniCache	201
B.1.2	Venus	201
B.2	Server Structure	208
B.2.1	Vice File Server	208
B.2.2	Authentication Server	213
B.2.3	Update System	213

List of Figures

2.1	Venus State Transition Diagram	13
2.2	Sample Hoard Profile	14
2.5	Type-independent Fields of the CML Record	17
2.9	Coda Client Structure	23
2.10	Coda Server Structure	25
3.1	Calculating RPC2 Retransmission Intervals	31
3.2	RPC2 Retransmission Intervals	32
3.3	Collecting RTT Observations	34
3.4	SFTP File Transfer: Server to Client	37
3.5	SFTP File Transfer: Client to Server	38
3.6	Two-way Timestamping in SFTP	40
3.7	SFTP Packet Sets	42
3.8	Transmission Log Record Formats	43
3.9	Transmission Log	44
3.10	Measuring SFTP Rounds	46
3.11	SFTP Records and Retransmission	48
4.1	Obtaining a Volume Callback	59
4.2	Validating by Volume	60
4.3	Breaking a Volume Callback	62
4.4	Interface for Volume Version Stamps	63
4.5	Vice Status Block	65

5.1	Venus State Transition Diagram	71
5.2	CML During Trickle Reintegration	76
5.3	Reintegration RPC	76
5.5	Shadowing Cache Files	81
5.6	Interface for Reintegration by Fragment	86
5.11	Effect of Aging on CML Optimizations, Base Case, Day Traces	99
5.12	Effect of Aging on CML Optimizations, Base Case, Week Traces	100
5.14	Effect of Aging on CML Optimizations, Day Traces	104
5.15	Effect of Aging on CML Optimizations, Week Traces	105
5.17	Effect of Aging on CML Optimizations, Excluding τ_{mp} , Four-Hour Maximum, Day Traces	108
5.18	Effect of Aging on CML Optimizations, Excluding τ_{mp} , Four-Hour Maximum, Week Traces	109
5.20	Effect of Aging on CML Optimizations, Excluding τ_{mp} , Day Traces	111
5.21	Effect of Aging on CML Optimizations, Excluding τ_{mp} , Week Traces	112
6.1	Advice Monitor Interaction	114
6.3	Weakly Connected Miss	116
6.4	Cache Miss Handling	117
6.5	Augmenting the Hoard Database	118
6.6	Specifying an HDB Entry	118
6.7	Controlling the Data Walk	120
6.8	Patience Threshold versus Hoard Priority	122
7.1	Experiment Configuration	126
7.6	Validation Time Under Ideal Conditions	133
7.13	Compressibility of Trace Segments	146
7.16	Performance of Trace Replay ($\lambda = 1$ second, $A = 300$ seconds)	147
7.18	Performance of Trace Replay ($\lambda = 1$ second, $A = 600$ seconds)	148
7.20	Performance of Trace Replay ($\lambda = 10$ seconds, $A = 300$ seconds)	149
7.22	Performance of Trace Replay ($\lambda = 10$ seconds, $A = 600$ seconds)	150

LIST OF FIGURES

A.1 Client State Transitions – Invalidation Based, Large Granularity 182

A.2 Worst Case Behavior During a Failure 196

List of Tables

2.3	4.3 BSD File System Interface	15
2.4	Coda Updates and UNIX System Call Mapping	16
2.6	Type-specific Fields of CML Records	18
2.7	CML Optimization Templates	19
2.8	Version and Value Certification	21
5.4	Compatibility Matrix for Object Locks	79
5.7	Contents of Trace Records	93
5.8	Summary of the Work-day and Full-week Traces	94
5.9	Trace Filter Specification	95
5.10	Unoptimized and Optimized CML Sizes, Base Case	98
5.13	Unoptimized and Optimized CML Sizes, Full Trace Length	103
5.16	Unoptimized and Optimized CML Sizes, Excluding /tmp, Four Hour Maximum	107
5.19	Unoptimized and Optimized CML Sizes, Excluding /tmp, Full Trace Length	110
6.2	Advice Monitor Interfaces	115
7.2	Transport Protocol Performance	127
7.3	Contents of Hoard Profiles for Five Coda Users, by Volume	129
7.4	Emulated versus Real RPC at 9.6 Kbps	130
7.5	Cache Recovery Time	132
7.7	Mond Clients and Data Collection Length	135
7.8	Volume Classification	136
7.9	Observed Volume Validation Statistics - Desktops	137

7.10	Observed Volume Validation Statistics - Notebooks	138
7.11	Incidence of Volume Callback Breaks	140
7.12	Incidence of False Sharing	140
7.14	Segments Used in Trace Replay Experiments	146
7.15	Performance of Trace Replay ($\lambda = 1$ second, $A = 300$ seconds)	147
7.17	Performance of Trace Replay ($\lambda = 1$ second, $A = 600$ seconds)	148
7.19	Performance of Trace Replay ($\lambda = 10$ seconds, $A = 300$ seconds)	149
7.21	Performance of Trace Replay ($\lambda = 10$ seconds, $A = 600$ seconds)	150
7.23	Residual Effect of File Contention	151
7.24	Data Generated During Trace Replay ($\lambda = 1$ second, $A = 300$ seconds)	153
7.25	Data Generated During Trace Replay ($\lambda = 1$ second, $A = 600$ seconds)	154
7.26	Data Generated During Trace Replay ($\lambda = 10$ seconds, $A = 300$ seconds)	155
7.27	Data Generated During Trace Replay ($\lambda = 10$ seconds, $A = 600$ seconds)	156
B.1	VFS and Vnode Interfaces	200
B.2	MiniCache Interface	202
B.3	Venus Thread Types	203
B.4	Callback Interface	204
B.5	RVM Library Interface	206
B.6	Vice Interface	209
B.7	File Server Thread Types	210
B.8	Server Inode Interface	211

Chapter 1

Introduction

The focus of this dissertation is the use of low bandwidth, intermittent, and potentially expensive wireless or wired networks for mobile file access. The ability to access data from anywhere will be an important capability in future information systems. The demand for ubiquitous data access is evident in the increasing prevalence of mobile computing and wireless communication. Mobile computers encounter a wide range of network characteristics in the course of their journeys. At work, they may have access to the cheap, reliable, high-speed connectivity typified by a local area network. *Strong connectivity* refers to such an environment. In other locations, they must rely on networks with serious shortcomings: intermittence, low bandwidth, and expense. *Weak connectivity* encompasses networks with one or more of these properties. For the foreseeable future, strong connectivity will be limited to a few oases, such as work or home, in a vast desert of weak connectivity. The design of distributed file systems has traditionally been based on an assumption of strong connectivity. Yet, to achieve the ideal of “access to data from anywhere” they must be able to make effective use of weak connectivity.

This chapter begins with context on distributed file systems. It then describes *disconnected operation*, an initial step towards providing ubiquitous data access, and discusses its shortcomings. Next, it discusses the use of weak connectivity to alleviate these problems. The chapter concludes with a road map for the rest of the document.

1.1 Distributed File Systems

Distributed file systems such as the Andrew File System (AFS) [113, 82, 49], Sun’s Network File System (NFS) [108], and Novell Netware [92] have become popular in a variety of environments. There are a number of reasons for the success of distributed file systems. First, they facilitate the sharing of information between users. Second, they increase mobility of individual users by providing access to data from different locations. Third, they are

extensible, allowing storage to be added as needed in a cost-effective way. Last, they simplify the administration of large numbers of machines. Tasks such as backup and software installation and maintenance are performed by operators rather than individual users.

Most distributed file systems are organized according to the *client-server model*. A nucleus of servers acts as the repository for data, which clients access through a standard system interface. To improve performance, clients *cache* files or parts of files in memory, on local disk, or both. To improve availability, some file systems *replicate* files at multiple sites. Support for replication varies; client access may be read-only or read-write, and updates during network partitions may or may not be allowed. Distributed file systems typically assume that clients and servers are strongly connected.

1.2 Disconnected Operation

Disconnected operation [62, 63] is a mode of operation in which a client uses cached data to operate during server and network failures. It can be viewed as the extreme case of weakly connected operation – the mobile client is effectively using a network of zero bandwidth, infinite latency and no cost. The ability to operate disconnected can be useful even when connectivity is available. For example, disconnected operation can extend battery life by avoiding wireless transmission and reception. It can reduce network expense, an important feature when charges are high. It allows radio silence to be maintained, a vital capability in military applications. And, of course, it is a viable fallback position when network characteristics degrade beyond usability.

But disconnected operation is not a panacea. A disconnected client suffers from many limitations:

- *Updates are not visible* to other clients.
- *Cache misses* are not transparent; a user may be able to work in spite of some cache misses, but certain critical misses may impede progress.
- *Updates made while disconnected are at risk* if the client is damaged, lost, or stolen.
- The danger of *update conflicts* (both write-write and read-write) increases with prolonged disconnections if the system allows partitioned updates [46, 50, 63].
- *Resource exhaustion*, especially that of cache space, is a concern during long disconnections.

1.3 The Thesis

The goal of this research is to alleviate the limitations of disconnected operation by exploiting weak connectivity. How successful the system is depends on the quality of the network. With a very weak connection, a user is little better off than when disconnected; as network quality improves, the limitations decrease in severity and eventually recede into insignificance. This leads to the thesis statement:

File system availability and usability can be significantly improved by using weak connectivity to address the limitations of disconnected operation. This goal can be achieved while preserving binary compatibility with a broad and important class of existing applications.

1.3.1 Scope of Thesis

This thesis focuses on the use of weak connectivity within a file system. It does not address external network applications, or their interaction with the file system. This thesis makes the following assumptions about weak connectivity and the network configuration between the client and the server.

- The client has only one network active at a time. For example, it is not connected via LAN and phone line to the same servers at the same time. If a choice of networks is available, the selection is made by a layer below the file system (e.g., MosquitoNet [7]).
- Replicated servers are strongly connected to each other, but they may be weakly connected to clients.
- The network connection is reasonably symmetric. Configurations such as a high bandwidth forward channel and a low bandwidth backward channel, as in cable TV systems, are outside the scope of this thesis.
- The client connects to the network at least occasionally, of the order of hours or days.
- The client makes no assumptions about the underlying network topology. In particular, different clients may see very different topologies.
- The client is given no guarantees about network performance. The focus is on observing and adapting to conditions, whatever they might be.

1.3.2 Approach

The approach of this work is best characterized as *application-transparent adaptation*. The system bears full responsibility for coping with the demands of weak connectivity. It strives to preserve the illusion of strong connectivity regardless of connection strength, straying from that ideal only when usability would be harmed. This approach preserves upward compatibility by allowing applications to run unchanged. The design is based on four guiding principles:

- *Don't punish strongly-connected clients.*
It is unacceptable to degrade the performance of strongly-connected clients on account of weakly-connected clients. This precludes use of a broad range of cache write-back schemes in which a weakly-connected client must be contacted for token revocation or data propagation before other clients can proceed.
- *Don't make life worse than when disconnected.*
While a minor performance penalty may be an acceptable price for the benefits of weakly-connected operation, a user is unlikely to tolerate substantial performance degradation.
- *Do it in the background if you can.*
Network delays in the foreground affect a user more acutely than those in the background. As bandwidth decreases, network usage should be moved into the background whenever possible. The effect of this strategy is to replace intolerable performance delays by a degradation of availability or consistency – lesser evils in many situations.
- *When in doubt, seek user advice.*
As connectivity weakens, the higher performance penalty for suboptimal decisions increases the value of user advice. Users also make mistakes, of course, but they tend to be more forgiving if they perceive themselves responsible. The system should perform better if the user gives good advice, but should be able to function unaided.

The unifying theme of this work is an emphasis on higher levels of the system. Because connectivity assumptions permeate the design of a system, a system based on LAN connectivity may be casual about network usage not only at the communication protocol layer but also in higher system layers. For example, upper layers of the system may communicate more frequently than necessary, and may not cache as aggressively as they could. Therefore, efforts towards reducing network usage must focus on higher system layers as well as lower ones. This dissertation will show that an emphasis on higher level mechanisms results in substantial benefits for weakly-connected operation. Further low level improvements may enhance those mechanisms, but cannot replace them.

More generally, this work was strongly influenced by two classic principles of system design: favoring *simplicity* over unwarranted generality [69], and respecting the *end-to-end argument* when layering functionality [107].

1.3.3 Mechanisms for Weak Connectivity

This goal of this work is to provide the mechanisms necessary to use weak connectivity effectively. It then defines simple, minimal policies using these mechanisms. The system provides four mechanisms, which were motivated by actual experience:

- *Communications layer adaptation.*
To adapt to network conditions, one must first discover what they are. The communications layer gathers data on network conditions and exports it to higher layers of the system as well as adapting internally.
- *Rapid cache validation.*
To recover from network failures, a client must resynchronize its cached state with servers. This component allows the client to recover quickly in most instances, an important capability in intermittent environments.
- *Trickle reintegration.*
This component propagates updates to servers asynchronously to hide network latency. Updates become visible to other clients sooner, allowing sharing and reducing the window of vulnerability to conflicts. The probability of data loss through failure or theft of the mobile is reduced, because data is available at servers. Finally, cache resources can be reallocated if necessary.
- *Cache miss handling.*
Weakly connected cache misses may have large service times, rendering them nontransparent. This component attempts to reduce service times on certain kinds of cache misses. If that is not sufficient, it solicits advice from the user regarding cache misses whose service times threaten to be lengthy.

All of the mechanisms except for rapid cache validation are *reactive*; that is, they change their behavior based on observed network performance. This adaptation is crucial in a system expected to cope with conditions that are both wide ranging and highly variable. Rapid cache validation is used regardless of connection strength, but improves performance dramatically while weakly connected.

1.3.4 Validation of Thesis

This thesis was investigated by designing the above set of mechanisms for weak connectivity and implementing them in a distributed file system called Coda [114, 63, 115]. Coda, a descendant of AFS, has as its main goal providing high availability in the face of server and

network failures. Its support of disconnected operation makes it an ideal vehicle for this work. Coda has been in active use since 1991 by roughly two dozen people. An evaluation based on empirical measurements and controlled experiments provides validation of the thesis statement.

1.4 Document Roadmap

The rest of this document consists of eight chapters. Chapter 2 describes the context of this work, and gives a high level overview of the Coda file system. Details regarding the implementation are deferred to Appendix B.

Chapters 3 through 6 describe the mechanisms for weak connectivity in Coda. They begin in Chapter 3 with the workings of the communications layer. This is the layer that detects and adapts to changing network conditions, and provides information on network performance to higher layers of the system.

Chapter 4 describes a mechanism for coping with intermittent environments by providing a means for clients to recover from failures quickly. A correctness analysis of this mechanism is provided in Appendix A.

Chapters 5 and 6 describe how weakly connected clients perform updates and handle cache misses, respectively. The mechanisms described in both chapters adapt to network conditions based on the information provided by the communications layer.

Chapter 7 evaluates the mechanisms for weak connectivity in Coda. It presents empirical results gathered from the system in actual use over the past year, and quantitative results from controlled experiments.

This document concludes with a discussion of related work in Chapter 8, and summarizes the contributions of this thesis in Chapter 9.

Chapter 2

Coda File System

This chapter describes the context of this thesis, the Coda File System. The first section provides a high-level overview of Coda, its history, and design rationale. The second section describes Coda's mechanisms for high availability at a high level. The last two sections provide an overview of the implementation of Coda clients and servers. Implementation details are deferred to Appendix B.

2.1 Design Goals

Coda is a distributed UNIX file system that strives to provide high data availability. It is a descendant of the Andrew File System (AFS) and as such inherited its design goals of scalability, performance, security, and operability.¹ Like AFS, it exports a single, shared, location-transparent name space. It also retains some of AFS's usage assumptions. In particular, the system is intended for use in an office or research environment, where typical activities are software development, text editing, document preparation, electronic mail, and so on. It is specifically not intended to support databases.

2.1.1 Scalability

Coda is divided into a small collection of *servers* and a much larger collection of *clients*. The servers are collectively called *Vice*, are physically separated from clients, and are dedicated solely to file service. At the client, the operating system intercepts system calls on *Vice* objects and directs them to a process called *Venus*, which communicates with *Vice* as necessary to

¹Coda is derived from the second of three versions of AFS developed at Carnegie Mellon University. Unless otherwise specified, the term AFS refers to this version.

service file system requests. To maximize the number of clients a server may support, most of the work required for file access is performed by clients. Because of this division of labor, clients are assumed to be reasonably powerful, general purpose computers, with a low to moderate amount of local disk storage. They are usually operated by a single user. Typical clients are desktop workstations and notebook computers, rather than specialized devices such as PDAs [119] or ParcTabs [128].

2.1.2 Performance

Venus makes extensive use of caching at the client. In addition to caching files, Venus also caches directories and symbolic links to improve the efficiency of pathname translation. File status and data are cached separately. Venus caches entire files rather than file blocks, because there is substantial empirical evidence that most files are small and applications often access entire files [6, 13, 39, 95]. This strategy has lower file transfer overhead per byte, and simplifies cache management considerably.

Cache coherence is maintained using *callbacks*. When a client caches a file from a server, the server promises to notify it if the file changes. This promise is called a *callback*. The client may use the file without further communication with the server until told otherwise. An invalidation message is called a *callback break*. If a client receives a callback break for an object, it invalidates the cached copy and re-fetches the object when next referenced. Network partitions complicate matters, because a server may not be able to break a callback with a client. Until the client realizes the server is unreachable, it believes, perhaps incorrectly, that its cached files are valid. To bound this window of vulnerability, clients probe servers periodically. If a failure occurs, Venus considers its cached files suspect until it validates them with the server upon reconnection.

Venus ensures the currency of objects involved in a system call by checking that the object is cached and has a callback. There is one exception: for open files, coherence is maintained at the granularity of *open-close sessions*. Venus intercepts only open and close system calls. Reads and writes to a file are performed directly on the cached copy. If the file is written, Venus forwards the updated copy to the server only when the file is closed. Sessions reduce client-server communication, but relax UNIX file semantics. Only processes on the same client can observe the results of a write before a file is closed.

Objects in the distributed file system are named with unique, low-level identifiers called *fids*. Venus performs all translation from pathnames to fids; servers are ignorant of pathnames. Since pathname translation is one of the most frequently performed tasks in a file system, this two-level naming scheme reduces server load by shifting the burden to clients.

2.1.3 Security

Coda and AFS prevent unauthorized release and modification of information in three ways. First, clients and servers are physically as well as logically separated, and are treated very differently from a security standpoint. Servers are *trusted*. They are located in physically secure areas, are accessible only to trusted operators, and run only trusted programs. Clients, on the other hand, are *untrusted*. They are under the control of individual users, who may modify their hardware and software. They may be located in areas that are not physically secure, such as a public workstation cluster. The network connecting clients and servers is not physically secure, and it is possible to eavesdrop on network traffic. Second, clients and servers use an authentication mechanism based on the Needham and Schroeder private key authentication scheme [88], and communicate using a remote procedure call package that supports authenticated connections and packet encryption.² Third, access to the file system is controlled through *access lists*, which specify the access rights of users and groups of users on directories. The practical upshot of these security mechanisms is if a client is subverted, the damage is limited to only those files to which the client has access rights. Details on the security mechanisms are provided by Satyanarayanan [110].

2.1.4 Operability

One of the goals of AFS and Coda is that it should be easy for a small staff to run and monitor the system. To this end, the file name space is divided into *volumes* [121], each forming a partial subtree. Volumes are glued together at *mount points*. Venus transparently recognizes and crosses volume boundaries during pathname translation. A volume is assigned to a single disk partition at a server; multiple volumes may reside on the same partition. Volumes may grow or shrink in size, and may be subject to disk quotas. Volumes may be moved from server to server; Venus uses a *volume location database (VLDB)* to locate the server for a volume. Read-only copies, or *clones*, of volumes may be created to increase availability and balance load over a set of servers. Backups are performed by creating read-only clones of volumes and then transferring them to backup storage. Volumes are typically created for individual users or projects.

2.2 Mechanisms for High Availability

Coda uses two complementary mechanisms to provide resilience to server and network failures. The first, *server replication*, involves storing copies of data at multiple servers. The

²In practice, Coda uses authenticated connections, but not packet encryption.

second, *disconnected operation*, allows a client to continue operating when no servers are accessible. This section provides background on Coda's high availability mechanisms. The following descriptions correspond to the original versions of these mechanisms as documented by Kumar [66, 67, 68] and Kistler [62, 63]. Changes to these mechanisms made prior to this dissertation are noted. For modifications resulting from this work, the reader is referred to the appropriate sections later in this document.

2.2.1 Server Replication

Server replication decreases the probability that data is unavailable by storing copies at multiple sites. The unit of replication is the volume, and the number and identity of the replication sites is specified when the volume is created. The set of sites at which a volume is stored is the *volume storage group (VSG)*. At any time, a client may be able to contact only some VSG members because of server or network failures. This subset is the *accessible volume storage group (AVSG)*. Different clients may have different, even non-intersecting AVSGs for the same volume.

2.2.1.1 Optimistic Replication

Coda uses an *optimistic replication* scheme, allowing updates in any network partition. This strategy contrasts with pessimistic replication, which restricts updates to at most one partition. Optimistic replication provides greater availability by trading off consistency between network partitions. That is, an object may be updated in multiple partitions, and those updates may conflict. Therefore, a system employing optimistic replication must provide a mechanism for detecting and coping with partitioned updates. Evidence suggests that optimistic replication is a reasonable strategy in distributed UNIX file systems because of the low degree of write-sharing [63].

2.2.1.2 Replica Control Algorithm

The protocol for accessing the servers is best described as *read-status-from-all, read-data-from-one, write-all*. When Venus fetches a file from the servers, it transfers file data from only one AVSG member, called the *preferred server*. However, it obtains status information from all of the replicas to verify that the object is consistent across AVSG members, and the preferred server has the latest copy of the data. If this is not the case, servers with stale data are notified and the server with the latest copy is made the preferred server.

When an object is updated, Venus contacts all AVSG members. The update proceeds in two phases. In the first phase (COP1), each server performs the update, and stamps the objects

involved with a client-generated version stamp called a *store ID*. In the second phase (COP2), Venus distributes to the AVSG the list of servers who performed the update successfully, called the *update set*. Communication with servers is performed in parallel using the MultiRPC parallel remote procedure call package [117].

Callbacks are maintained at all AVSG members. Venus probes the AVSG as in the non-replicated case to detect connectivity changes. If the AVSG shrinks there is the potential for a lost callback from the unavailable server. If the AVSG grows, there may be updated data from the newly available server. Venus considers cache entries suspect in this case until it validates them with the AVSG.

2.2.1.3 Conflict Detection

Coda detects *write-write* conflicts on files using *version vectors*, originally proposed for Locus [97]. A version vector is a summary of the update history of an object. The length of the vector is the number of replicas (i.e., the size of the VSG) for the object. Each entry contains the number of updates performed at the corresponding replication site. The version vector also includes the store ID of the most recent update to the object. Each replica of an object has a version vector associated with it.

When two version vectors A and B have the same values for each entry, the replicas are equal. If every entry in A is greater than or equal to the corresponding entry in B , A is said to *dominate* B . In this case, the replica at A is the more recent one. If some entries in A are greater than those in B and others are smaller, then A and B are said to be *inconsistent*. In this case, the replicas are diverging.

Venus detects conflicts lazily as it obtains the status for objects involved in a file system request. When Venus obtains the status of an object, it compares the version vectors. If they are not equal, Venus suspends the file system request and invokes a *resolution* protocol to merge the replicas automatically. If resolution completes successfully, Venus continues servicing the request using the merged version of the object. Otherwise, Venus flags the object as inconsistent, making it appear to the user as a dangling symbolic link. The object is rendered inaccessible until the user repairs it manually; a repair tool is provided for this purpose.

2.2.1.4 Resolution and Repair

Coda's resolution protocol is executed between servers and consists of determining the set of partitioned updates, communicating that set to the AVSG, checking the resolvability of the updates, performing the partitioned updates at relevant sites, and marking the object as either resolved or inconsistent. There are separate strategies for files and directories because of their different structure and update methods. Directories are structured objects with a well-defined

set of update operations known to the system. On the other hand, files are unstructured byte streams whose update patterns are specific to an application.

Directory resolution is a four-phase protocol based on operation logging [67]. Each server maintains a log of updates to the directory. When Venus triggers resolution, a single server acts as coordinator for the protocol. The coordinator collects and compares the server logs to determine the partitioned updates, and then distributes the logs to the other servers. The servers read the logs to determine which updates they missed, and then perform them as *compensating operations*.

File resolution comes in two flavors. Servers can resolve file replicas among themselves if there is a dominant replica. In that case, the original version of resolution sends the dominant copy of the file to all AVSG members. The implementation has since been refined to send the dominant copy to only those AVSG members that need it. In effect, servers with stale versions perform the compensating operation of replacing the file. This refinement is described in more detail in Section 5.3.5. If the version vectors are inconsistent, Venus invokes an *application specific resolver (ASR)*, if supplied by the application writer, that contains enough information about the semantics of the file data to resolve the replicas [68].

If an object is marked inconsistent, it is inaccessible until repaired manually. Coda supplies a repair tool that, when run at a client, exposes the replicas of the object *in situ*, and provides commands with which a user can resolve the object manually.

2.2.2 Disconnected Operation

Disconnected operation occurs when the AVSG becomes empty. Disconnections come in two flavors – *involuntary*, which are caused by network or server failures, and *voluntary*, which occur when a user unplugs a client such as a notebook computer from the network. Venus bears the brunt of supporting disconnected operation. It has three main responsibilities. First, while connected, it must cache files that will be useful during a disconnection. Second, while disconnected, it must service file requests using cached data. Last, upon reconnection, it must propagate disconnected updates to the servers.

These tasks are represented as states within Venus, shown in Figure 2.1. Most of the time, Venus is in the *hoarding* state. In this state, it services connected mode requests with the AVSG, maintains cache coherence using callbacks, and caches useful files. When a disconnection occurs, Venus enters the *emulating* state, so named because it emulates the distributed file service using local resources. It services requests from its cache, and records updates performed locally. Upon reconnection, Venus enters the transient *reintegrating* state, merges disconnected updates with servers, and then proceeds to the hoarding state. Since VSGs vary between volumes, Venus may be in different states with respect to different volumes. Modifications to this state diagram are described in Section 5.2.1.

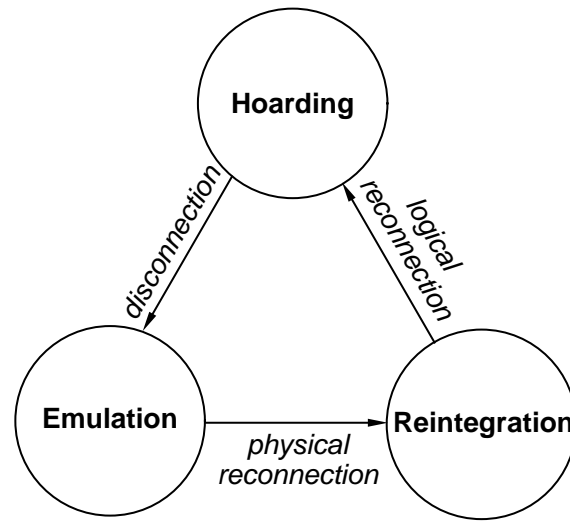

Figure 2.1: Venus State Transition Diagram

This figure shows Venus volume states and transitions as described by Kistler [62].

2.2.2.1 Hoarding

When Venus is connected to a server, it is in the hoarding state. In addition to its connected mode responsibilities, it must also cache useful data to prepare for disconnection. Normally, Venus manages its cache using an LRU algorithm. However, caching for disconnection is a long-term endeavor, for which standard LRU algorithms are insufficient. Venus therefore allows a user to indicate which data would be most valuable during a disconnection by loading *hoard profiles*. A hoard profile specifies a set of files to be cached and gives an indication of their importance, called the *hoard priority*. An example of a hoard profile is shown in Figure 2.2. Venus stores hoard specifications in its *hoard database (HDB)*.

In managing its cache, Venus must balance both the short-term need of caching for performance (LRU) with the long-term need of caching for availability (hoarding). Venus uses a prioritized caching algorithm which combines both reference information and the hoard priority of an object, if any. Periodically, Venus executes a *hoard walk* to ensure that the highest priority items are cached and valid. The hoard walk is executed in two phases. The first phase, called the *status walk*, obtains status information for missing objects and determines which, if any, should be cached. The second phase, called the *data walk*, fetches the data for objects selected during the status walk. A hoard walk may also be requested by a user, usually before a voluntary disconnection.

```

a /coda/usr/zoey/thesis 1000:d+
a /usr/misc/.tex/bin/virtex 100
a /usr/misc/.tex/bin/xdvi 50
a /usr/misc/.tex/lib/xdvi 50:c
a /usr/misc/.tex/bin/bibtex

```

Figure 2.2: Sample Hoard Profile

This figure shows part of a hoard profile. Hoard priorities range from 1-1000, and default to 10 if not specified. The specifiers “c” and “d” mean hoard children and descendants of the object, respectively. The “+” means hoard future children or descendants of an object as well as those present when the profile is loaded.

2.2.2.2 Server Emulation

When Venus detects that an AVSG has become empty, it places the affected volumes in the emulating state. In this state, Venus attempts to mask the disconnection by servicing file system requests locally using cached data. Of course, if an object is not cached, file service is impeded. In this case, Venus can either return an error or block until reconnection.

Disconnected update requests are performed locally and logged in stable storage, so that they may be replayed at the server upon reconnection. The structure that describes the updates is called the *client modify log (CML)*. Venus maintains a CML for each volume represented in the cache. When it performs a disconnected update, it appends a log record to the CML for the appropriate volume. As shown in Tables 2.3 and 2.4, CML records correspond for the most part to updates in the UNIX API. The two main exceptions are the `store` record, which corresponds to the closing of a file opened for write, and the `repair` record, which is part of Coda’s application specific resolution mechanism.

Each CML record consists of a type-independent part and a type-specific part. The type-independent part is shown in Figure 2.5, while Table 2.6 shows CML record types and their type-specific fields. Every CML record, except for `store`, is self-sufficient. That is, there is no client state other than the record itself needed to correctly and completely replay the record at the server. The `store` records contains a reference to the cache container file for the object for the new file data. Objects referenced by a CML record are marked *dirty*. Dirty objects may not be replaced until cleaned by a successful reintegration, repaired after an unsuccessful reintegration, or purged forcibly from the cache.

Because updates can cancel each other, Venus takes advantage of this behavior by performing *log optimizations* over the CML. There are two kinds of log optimizations – *overwrites*

Operation	Description
<code>access</code>	Determine access permissions of an object.
<code>chmod</code>	Change mode bits of an object.
<code>chown</code>	Change owner of an object.
<code>close</code>	Delete an open descriptor.
<code>creat</code>	Create a new file.
<code>fsync</code>	Synchronize a file's in-core state with that on disk.
<code>ioctl</code>	Perform a control function on an open descriptor.
<code>link</code>	Make a hard link to an object.
<code>lseek</code>	Move the read/write pointer for an open descriptor.
<code>mkdir</code>	Make a directory with the specified path.
<code>mknod</code>	Make a special file.
<code>mount</code>	Mount a file system.
<code>open</code>	Open a file for reading or writing, or create a new file.
<code>read, readv</code>	Read input from an open descriptor.
<code>readlink</code>	Read value of a symbolic link.
<code>rename</code>	Change the name of an object.
<code>rmdir</code>	Remove a directory.
<code>stat</code>	Get object status.
<code>statfs</code>	Get file system statistics.
<code>symlink</code>	Make a symbolic link to an object.
<code>sync</code>	Write modified in-memory file system data to disk.
<code>truncate</code>	Truncate a file to a specified length.
<code>umount</code>	Remove a file system.
<code>unlink</code>	Remove a directory entry.
<code>utimes</code>	Set "accessed" and "updated" times for an object.
<code>write, writev</code>	Write output to an open descriptor.

Table 2.3: 4.3 BSD File System Interface

This table shows the 4.3 BSD UNIX file system API. In the descriptions above, the term "object" refers to a file, directory, or symbolic link.

```

chown(object, user)
    chown
chmod(object, user)
    chmod
utimes(object, user)
    utimes
store(file, user)
    [[creat | open] [read | write]* close] | truncate
create(directory, name, file, user)
    creat | open
mkdir(directory1, name, directory2, user)
    mkdir
symlink(directory, name, symlink, user)
    symlink
remove(directory, name, file, user)
remove(directory, name, symlink, user)
    rename | unlink
rmdir(directory1, name, directory2, user)
    rename | rmdir
link(directory, name, file, user)
    link
rename(directory1, name1, directory2, name2, object, user)
    rename
repair(file, user)
    (no mapping)

```

Table 2.4: Coda Updates and UNIX System Call Mapping

The leftmost lines show the interface for Coda update operations, and the indented lines show the mapping from UNIX system calls. Syntax is that of regular expressions. Source: Adapted from Kistler [62], Table 3.2, page 28.

```
ClientModifyLog *log;
rec_dlink handle;

ViceStoreId sid;
Date_t time;
UserId uid;
int tid;
CmlFlags flags;

< type specific fields >

dlist *fid_bindings;
dlist *pred;
dlist *succ;
```

Figure 2.5: Type-independent Fields of the CML Record

This figure shows the fields of the CML record common to all updates. Each record contains a backpointer to the CML itself (`log`) and to its successor `handle`. The modify-time of the update is in `time`, the author of the update is indicated by `uid`. Two fields are used as “transaction identifiers”; they are the store id `sid` and `tid`. The `fid_bindings` field contains pointers to the `fsobjs` that the record references. Pointers to lists of preceding and succeeding records are contained in `pred` and `succ`, respectively.

Record Type	Items recorded (with type independent fields)
<code>chown</code>	fid, new owner, version id
<code>chmod</code>	fid, new mode, version id
<code>utimes</code>	fid, new modify time, version id
<code>store</code>	fid, new length, new contents, version id, offset, server handles
<code>create</code>	parent fid, name, child fid, mode, version id
<code>mkdir</code>	parent fid, name, child fid, mode, parent version id
<code>symlink</code>	parent fid, old name, new name, child fid, mode, parent version id
<code>remove</code>	parent fid, name, child fid, link count, parent version id, child version id
<code>rmdir</code>	parent fid, name, child fid, parent version id, child version id
<code>link</code>	parent fid, name, child fid, parent version id, child version id
<code>rename</code>	from parent fid, from name, to parent fid, to name, from fid, from parent version id, to parent version id, from version id
<code>repair</code>	fid, length, modify time, owner, mode, version id

Table 2.6: Type-specific Fields of CML Records

This table shows the type-specific contents of CML records for each operation. The type-independent fields are given in Figure 2.5. The `store` record, which represents the close of a file opened for write, includes new data by reference from a separate UNIX file.

Overwritten Subsequence	Overwriter
$[\text{store}(f, u) \mid \text{utimes}(f, u)]^+$	$\text{store}(f, u)$
$\text{chown}(f, u)$	$\text{chown}(f, u)$
$\text{chmod}(f, u)$	$\text{chmod}(f, u)$
$\text{utimes}(f, u)$	$\text{utimes}(f, u)$
$[\text{store}(f, u) \mid \text{chown}(f, u) \mid \text{chmod}(f, u) \mid \text{utimes}(f, u)]^+$	$\text{remove}(\chi, \chi, f, u)$
$[\text{chown}(s, u) \mid \text{chmod}(s, u) \mid \text{utimes}(s, u)]^+$	$\text{remove}(\chi, \chi, s, u)$
$[\text{chown}(d, u) \mid \text{chmod}(d, u) \mid \text{utimes}(d, u)]^+$	$\text{rmdir}(\chi, \chi, d, u)$

(a) Overwrite Optimizations

Initiator	Identity Subsequence	
	Intermediaries	Terminator
$\text{create}(\chi, \chi, f, \chi)$	$[\text{store}(f, \chi) \mid \text{chown}(f, \chi) \mid \text{chmod}(f, \chi) \mid \text{utimes}(f, \chi) \mid \text{link}(\chi, \chi, f, \chi) \mid \text{remove}(\chi, \chi, f, \chi) \mid \text{rename}(\chi, \chi, \chi, \chi, f, \chi)]^*$	$\text{remove}(\chi, \chi, f, \chi)$
$\text{symlink}(\chi, \chi, s, \chi)$	$[\text{chown}(s, \chi) \mid \text{chmod}(s, \chi) \mid \text{utimes}(s, \chi) \mid \text{rename}(\chi, \chi, \chi, \chi, s, \chi)]^*$	$\text{remove}(\chi, \chi, s, \chi)$
$\text{mkdir}(\chi, \chi, d, \chi)$	$[\text{chown}(d, \chi) \mid \text{chmod}(d, \chi) \mid \text{utimes}(d, \chi) \mid \text{rename}(\chi, \chi, \chi, \chi, d, \chi)]^*$	$\text{rmdir}(\chi, \chi, d, \chi)$

(b) Identity Subsequence Optimizations

Table 2.7: CML Optimization Templates

This figure shows optimizations that may be taken over CML records. There are two kinds of optimizations – overwrites, shown in Part (a), and identity subsequences, shown in Part (b). Overwrites replace a sequence of log records (the overwritten subsequence) with a single update (the overwriter). Identity subsequences remove a sequence of log records, beginning with the initiator, including intermediaries, and ending with the terminator. In the tables above, f is a file, s is a symbolic link, d is a directory, u is a user ID, and χ means the value of the argument is not relevant for the cancellation. All updates must be authored by the same user; this condition is satisfied trivially by CML ownership. Source: Adapted from Kistler [62], Tables 6.2 and 6.3, pages 130 and 131.

and *identity subsequences*. In an overwrite optimization, a series of records collapses into one (e.g. repeated `stores` to the same file). In an identity subsequence optimization, a series of records may be eliminated completely (e.g., a `create` of a file followed by a `remove`). Log optimizations are given in Table 2.7. To simplify optimizations and reintegration, a non-empty CML is owned by one user. Only the CML owner may perform updates in a disconnected volume.

Persistence of the CML is guaranteed by placing it in *recoverable virtual memory* using the RVM package [116, 75], which provides failure atomicity and permanence of recoverable virtual memory structures. Details on the use of RVM are provided in Sectionsss:Persistence.

2.2.2.3 Reintegration

Reintegration is a transient process by which Venus transforms a volume from the emulating state to the hoarding state. It proceeds in three stages – the *prelude*, the *interlude*, and the *postlude*. The prelude refers to activities performed by Venus in preparation for reintegration. Venus places the volume in reintegrating state when it notices the AVSG has become non-empty and the following three conditions are met. First, a *triggering event* in the volume has occurred, such as a reference to an object in the volume. Second, all current activity in the volume has ceased. Reintegration obtains exclusive control of the volume; new activity is blocked for the duration. Third, there are authentication tokens for the CML owner.

The remainder of the prelude consists of the following four tasks. First, Venus cancels `store` records for files open for write. This is necessary because the data associated with the `store` record (i.e., the container file) may have been modified since the record was logged, and may no longer be consistent with that record. Second, Venus allocates permanent fids for objects that have temporary fids.³ Third, Venus marshals the log records into an in-memory buffer. Finally, the reintegrator thread sends an RPC to the server requesting reintegration.

The interlude is the processing of the reintegration request at the server. The server retrieves the CML from the client and unmarshals the log records. It then write-locks the objects identified in the CML. The server then checks the soundness of each operation through a process called *certification*. The server applies different checks depending on the update and object type, as summarized in Table 2.8. If the operations are sound, the server performs them tentatively. Next the server transfers new data associated with `store` records. These data transfers are called *backfetches*. If all is well, the server atomically commits the changes to recoverable storage. Otherwise, it discards the changes. In the current implementation, new data transfers can occur before reintegration. This reordering of backfetch is discussed in Section 5.3.2. An error in performing any part of the interlude, for any record, is sufficient cause for the server to

³If Venus runs out of pre-allocated fids while logging updates, it assigns newly-created objects temporary fids. Before reintegration, it must obtain permanent fids from the server and replace the temporary ones.

Operation	Certification
<code>chown(o, u)</code>	<i>o.version-id</i>
<code>chmod(o, u)</code>	<i>o.version-id</i>
<code>utimes(o, u)</code>	<i>o.version-id</i>
<code>store(f, u)</code>	<i>f.version-id</i>
<code>create(d, n, f, u)</code>	<i>d.data[n]</i>
<code>mkdir(d1, n, d2, u)</code>	<i>d1.data[n]</i>
<code>symlink(d, n, s, u)</code>	<i>d.data[n]</i>
<code>remove(d, n, f, u)</code>	<i>d.data[n]</i> , <i>f.version-id</i>
<code>remove(d, n, s, u)</code>	<i>d.data[n]</i> , <i>s.version-id</i>
<code>rmdir(d1, n, d2, u)</code>	<i>d1.data[n]</i>
<code>link(d, n, f, u)</code>	<i>d.data[n]</i>
<code>rename(d1, n1, d2, n2, o, u)</code>	<i>d1.data[n1]</i> , <i>d2.data[n2]</i> <i>o.data[``.``']</i> (if <i>o</i> a directory)

Table 2.8: Version and Value Certification

The purpose of certification is to ensure that reintegrated updates can be serialized after intervening activity at the server. The table above lists, for each operation, the fields that must match at the client and server before the update. In addition, the user *u* must have sufficient access rights to complete the update.

In *version* certification, the client must have updated the same version of the object present at the server. The *version-id* field of the object uniquely identifies its last update. (In the implementation, the version-id is the store ID field of the version vector.) If the server copy changed after the client performed the disconnected update, the version-ids will differ, and the check will fail.

The server uses *value* certification for directory operations. In value certification, the server checks the object's data, in this case directory entries. The update succeeds if the server can perform it on its copy of the directory, regardless of the version of the directory at the client. For example, if the client creates a file, the server checks that there is no directory entry with the same name in its copy. For remove, on the other hand, the server checks that there is a directory entry with the specified name. Value checking is less stringent than version checking; it takes advantage of the semantics of directory operations to allow the server to accept more reintegrated updates. In the table above, the checking of directory contents is denoted by the *data* field. The value of *d.data[n]* is the fid of the object bound to the name *n* in directory *d*, if any.

reject the entire reintegration. This failure model has changed, as described later in this section. Finally, the server releases the objects, and responds to the client.

The postlude occurs back at the client. If reintegration succeeds, Venus commits the local changes by clearing the dirty flags of the objects represented in the CML, and discarding the CML records. The behavior of Venus on failure has evolved. In the original implementation, Venus aborts the changes by spiting the objects involved away to a local file called a *closure*, purging them from the cache, and discarding the CML records. Failure representation in the current implementation takes a different form, described below. Commit and abort actions are performed as single RVM transactions. Venus then changes the volume state from reintegrating to hoarding.

Several refinements were made to the original implementation to support an early version of *isolation only transactions* (IOT), a mechanism for detecting read/write conflicts and encapsulating sequences of file system operations [73, 72]. The two main refinements are *incremental reintegration* and an improved failure model. Incremental reintegration allows Venus to reintegrate sets of CML records pertaining to a particular transaction instead of the whole log. The CML record includes a transaction identifier, and the prelude and postlude are parameterized by transaction identifier.

The failure model has been improved in two ways – the grain of failure reporting, and failure representation. The original implementation used *coarse-grained* failure reporting. Reintegration of a CML succeeds if and only if reintegration of each and every record succeeds. A single failure causes the entire CML to be rejected, even if the other records are independent of the offending update. The advantages of coarse-grained failure handling are simplicity and ease of implementation. This approach also captures certain dependencies the system cannot currently detect, such as read-write dependencies (e.g., `store foo, cat foo > bar`). The coarse-grained model has some disadvantages as well. Bandwidth used to transfer unrelated operations is wasted. Users find it difficult to determine which operation caused the failure, and inconvenient to restore the changes to an entire volume. The current implementation uses *fine-grained* failure reporting. If a failure occurs, the server aborts the reintegration and returns an index containing the position of the offending record. The client may then resend only those operations that are likely to succeed transparently to the user.

The failure representation has changed from exiling the offending objects to a closure, to marking them in conflict. They appear to the user in place, as dangling symbolic links, and must be repaired using the repair tool. The repair tool has been extended to expose and manipulate the local copy of an object along with the server replicas. Updates corresponding to objects requiring local repair remain in the CML.

Reintegration has undergone further transformation as a result of this work. These changes are described in detail in Chapter 5.

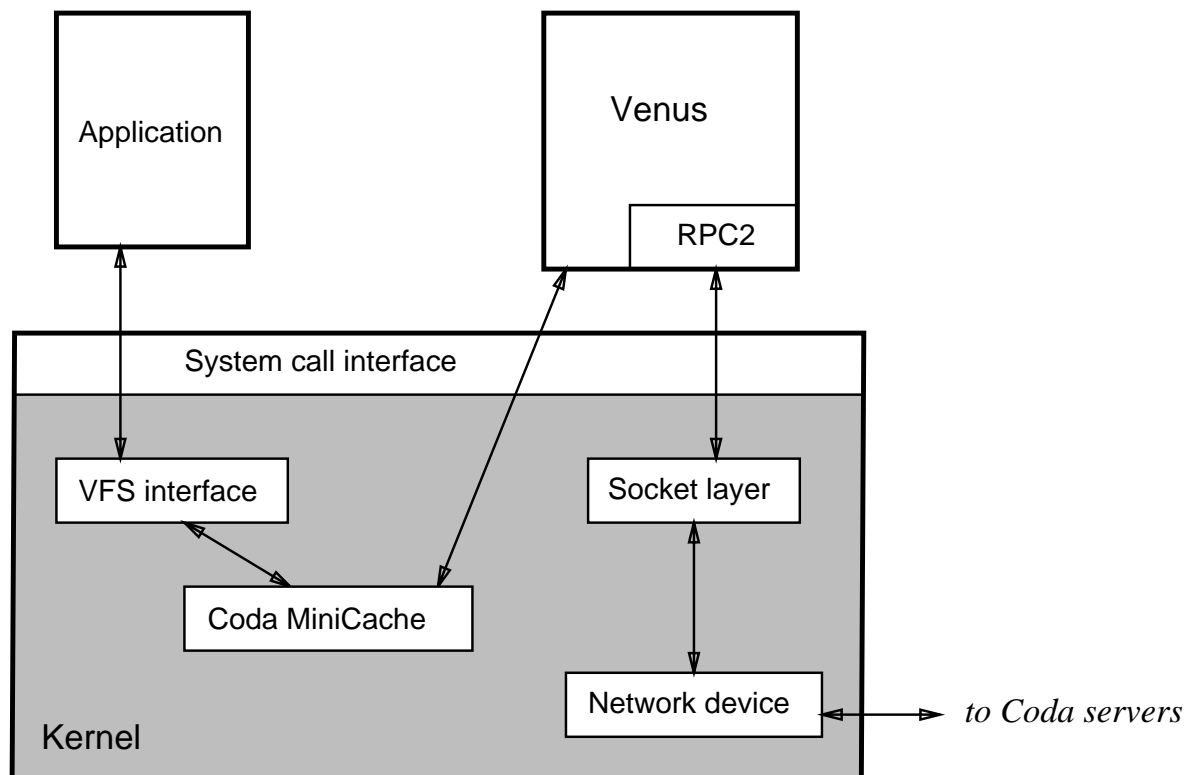

Figure 2.9: Coda Client Structure

2.3 Client Overview

Coda support on a client workstation consists of two components. The first component, called the *MiniCache* [123], is a small in-kernel module that implements the Sun Microsystems *Virtual File System (VFS) interface* [64], a standard system call intercept mechanism that allows multiple file systems to co-exist within a single Unix kernel. This interface is summarized in Table B.1. The second component is a much larger user-level cache manager called *Venus*. The primary responsibilities of Venus are to service user file system requests, maintain cache coherence while connected, and manage the cache within predefined resource limits. In addition, it must hoard data in anticipation of disconnection, log and reintegrate disconnected updates, detect diverging replicas and trigger their resolution or quarantine them for repair. Venus is implemented as a multi-threaded process using a lightweight co-routine thread package called LWP [111]. Although its functionality could be provided within the kernel for better performance, the user-level implementation is more portable and considerably easier to debug. The structure of a Coda client is illustrated in Figure 2.9. Details on the structure and implementation of client components are provided in Section B.1.

An application system call involving a Coda object is directed by the VFS layer to the Coda VFS. If the information required is contained within the Coda VFS, the call is serviced without involving Venus and control returns to the application. Otherwise, the kernel contacts Venus by writing a message to a pseudo-device. Venus reads the request from the pseudo-device, and if remote access is necessary, contacts the Coda file servers using the RPC2 remote procedure call package [111]. When Venus completes processing the request, it writes a response on the pseudo-device, and control returns back through the kernel to the application process.

2.4 Server Overview

Server support for Coda consists of a set of user-level processes, the *Vice file server*, and *authentication server*, and either an *update server* or an *update client*. One server is designated the *System Control Machine (SCM)*, and runs an update server; all other servers run an update client. Most servers run all three components, but this configuration is not necessary. Figure 2.10 shows an example server configuration.

The primary responsibilities of a Vice file server are to handle file system requests from Venus, break callbacks to Venus when objects are updated, and participate in the resolution protocol. The Vice file server exports the Vice interface, shown in Table B.6. Like Venus, the file server is a multi-threaded user-level process. The authentication server provides the means for establishing secure RPC connections between clients and servers. The update subsystem replicates and maintains the consistency of certain slowly changing system databases. Details on the structure and implementation of server components are provided in Section B.2.

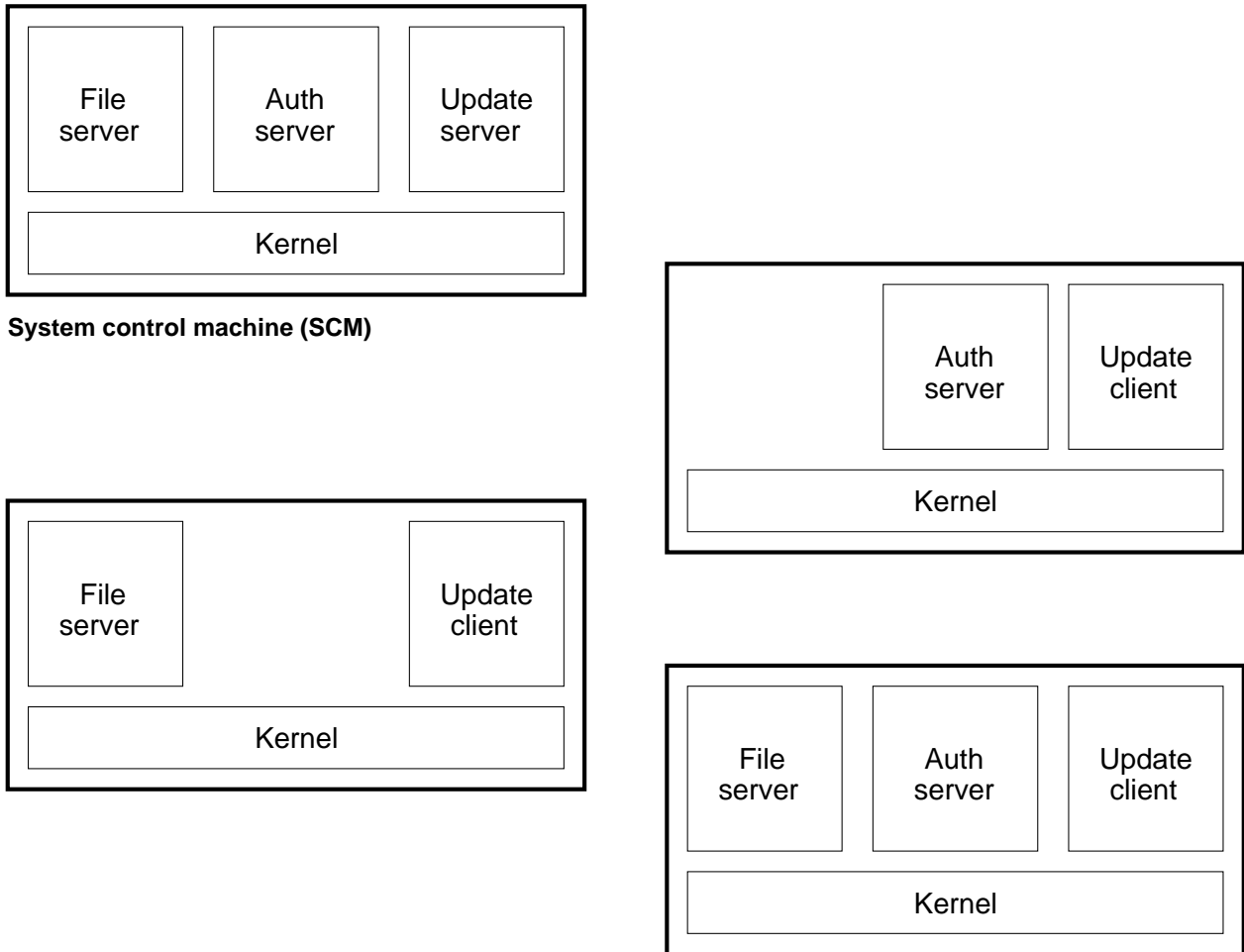

Figure 2.10: Coda Server Structure

Chapter 3

Communication Layer Adaptation

To adapt to changes in network conditions, a system must be able to gather information on network performance, and then adjust its behavior accordingly. Adaptation can occur at many levels of a system. For example, a transport protocol might adapt by collecting data on packet round trip times and adjusting its retransmission timeout. At a higher level, a movie player application might adapt by observing network throughput and adjusting the picture quality. An assumption underlying this adaptation at all levels is that performance in the recent past is a good predictor of performance in the near future.

The source of information on network conditions in Coda is its communications layer, consisting of transport protocols and connection management at the client and server. This layer gathers measurements on network transmissions between client and server which form the basis of estimates of future network performance used by Venus to adapt its behavior. The goals for this measurement gathering are as follows. First, the performance impact of obtaining the measurements should be minimal. Second, because network resources may be scarce, the communications layer should not perform any additional communication to gather information. Third, although Venus is the target “application” for this work, the mechanism should be general enough to support other adaptive applications. Finally, because this communications layer is part of an actively used production system, data gathering should be introduced in a compatible way, with minimal design and implementation changes to existing code.

This chapter describes the Coda communications layer. It begins with a discussion of design alternatives and describes the approach taken in this work. The next two sections describe the adaptive transport protocols Coda uses. The fourth section describes how the measurements exported to applications are collected, and how Venus derives and uses the estimates based on these measurements. The fifth section discusses the effect of server replication on the communications layer. The last section explores the relationship between the communications layer and quality of service (QoS) support.

3.1 Design Alternatives

Approaches for estimating network performance may be characterized by type of estimate, monitoring strategy, and placement of monitoring within the system. Estimates of network performance fall into two categories – *static* and *dynamic*. Static estimates are based on known characteristics of a network connection. For example, an Ethernet connection is nominally rated at 10 Mb/sec and is reasonably reliable. Static estimates may be derived from a variety of sources, such as from hints supplied by a user or application (e.g., “I’m connecting via modem now.”), the current network interface, or upcalls from lower layers when a mobile host changes location [56]. Static information allows the system to converge more rapidly to accurate estimates when discontinuities in performance occur, such as when a mobile host switches between network devices or changes locations. The obvious drawback of static estimates is they contain no information on actual network performance as observed by an application. Under pathological conditions, observed performance can deviate by orders of magnitude from nominal performance. In addition, an estimate based on the current network interface may be only a weak upper bound on performance, because the path to a destination may traverse a network segment whose characteristics are substantially worse than the segment adjacent to the client. Indeed, this is often the case with communication between stationary and mobile hosts.

Dynamic estimates are obtained by monitoring network usage. Monitoring may be *active* or *passive*. In active monitoring, a host generates network traffic for the sole purpose of collecting measurements (e.g., see [104]). Traffic may be generated periodically to keep estimates up-to-date. Active monitoring may affect or be affected by existing traffic (e.g., probe compression [12]), particularly if connectivity is weak. The cost of measurement may also be significant. In passive monitoring, a host measures only existing traffic. Passive monitoring has been used extensively on local area networks [81], where some or all traffic may be monitored using “promiscuous mode” [125]. Estimates based on passive monitoring can become stale if traffic is infrequent or irregular.

Where within a system should monitoring be performed? Its placement is influenced by the kinds of measurements one wishes to make. Monitoring at lower system layers, such as at the device driver level, may yield a more accurate picture of network usage, particularly if there are multiple tasks competing for that resource. On the other hand, measurements taken in higher layers may be more meaningful to applications. For example, effective throughput for a bulk transfer can be measured only at or above the transport layer, because protocol-specific knowledge is required to exclude overheads such as packet headers and retransmissions.

The communications layer of Coda uses adaptive transport protocols that export end-to-end measurements of network performance to applications. End-to-end measurements are the most meaningful in that they reflect the performance the application actually observes. Measurements are obtained through passive monitoring, but applications may implement active monitoring by

generating their own traffic. Venus derives estimates based on both measurements and static information to determine connectivity with respect to servers.

3.2 Remote Procedure Call

Client-server communication in Coda is performed using *remote procedure call* (RPC) [10]. Coda uses the RPC2 remote procedure call package [111], a portable, user-level RPC package built on UDP/IP [98]. This section describes the extensions to RPC2 that enable it to cope with poor or highly variable network performance.

3.2.1 Protocol Overview

RPC2 implements a remote procedure call service with *at-most-once* semantics [83]. Clients bind to servers using a $\langle host, portal, subsystem \rangle$ triple, where subsystem refers to a group of related remote procedure calls. Once a client binds to a server and establishes a connection, it may then send a request, which consists of an operation code and a set of parameters. The server replies with a return code and result parameters, if any. Only one request may be in progress on a connection at a time, but multiple connections may be established to permit concurrency.

RPC2 connections may include *side effects* to allow specialized network operations to be performed. Coda uses only one side effect, *SFTP*, a specialized streaming protocol for efficient bulk data transfer. Side effects are initiated by the server during an RPC, and operate from a different portal. For extensibility reasons, the RPC and side effect implementations are isolated from each other; RPC2 calls side effect routines only at certain well-defined points.

Since RPC2 is implemented using datagrams, it must provide its own reliable delivery. In the absence of failures, a reply serves as an acknowledgement for the request, and the next request serves as an acknowledgement for the reply. To detect failures, the client specifies a timeout period for an RPC, during which it must receive some sort of response from the server. During an RPC, the client periodically sends a *keepalive*, which is a retransmission of the request packet. If the server receives a keepalive for a request it has already received but has not yet serviced, it responds with a *busy* packet¹. To cope with lost reply packets, the server retains a copy of the most recent reply for one timeout period. If the server receives a keepalive for the most recently serviced request, it simply retransmits its saved copy of the reply.

¹Side effects do not affect the failure detection algorithm as long as the server responds to keepalives with busy packets.

3.2.2 Retransmission Strategy

Timeout and retransmission intervals are determined by two parameters: N , the number of retransmissions, and B_t , the keepalive interval. The values for these parameters are specified at RPC2 initialization, and are intended to characterize the likelihood of packet loss and the amount of time the server may take in responding to requests before the client declares it down. During an RPC, the client may send up to N retransmissions of a request to a server within B_t of the original request. The retransmissions B_1, B_2, \dots, B_N are distributed such that:

$$B_1 + B_2 + \dots + B_N = B_t, \quad B_i \leq B_{i+1} \quad (3.1)$$

If the client times out on the request for the i th time, it schedules its next retransmission for B_i later. If the client receives a busy packet, it schedules its next retransmission for a full B_t seconds later. The client declares failure at time t after the original request, where $B_t \leq t \leq 2B_t$. Failure is declared at time B_t after the original request if no retransmission provokes a response. The worst case occurs if a failure strikes immediately after the server sends a busy packet. In this case, the client does not declare failure until $2B_t$ after the original request.

Since different connections may observe different network performance, the retransmission intervals B_i are maintained on a per-connection basis. They are initialized as in Equation 3.1, with $B_{i+1} = 2B_i$, and are calculated using the algorithm shown in Figure 3.1. For example, the retransmission schedule for the RPC2 defaults of $B_t = 60$ and $N = 6$ is 0.47, 0.94, 1.89, 3.78, 7.56, and 15.12 seconds, with failure declared after an additional 30.24 seconds if no response is received from the server. These intervals are shown in Figure 3.2(a).

A lower bound is placed on the B_i to ensure retransmissions are not sent too soon after one another. The lower bound is initialized to a minimum lower bound of 300 milliseconds², and then adjusted upwards if necessary based on *round trip time estimates* [57]. Intuitively, the minimum retransmission interval B_1 should be no shorter than the time to send a request and receive a response. Whenever the round trip time estimate is changed, the retransmission intervals are recalculated while maintaining B_t , as shown in Figure 3.2(b).

Obviously one cannot increase B_1 arbitrarily and maintain both N and B_t ; either N must decrease or B_t must increase. RPC2 decreases N rather than increasing B_t , as shown in Figure 3.2(c), because lengthening the timeout would render system responsiveness unpredictable in the presence of failures.

3.2.2.1 Obtaining Round Trip Time Observations

An estimate of the round trip time (RTT) is based on observations. RPC2 collects RTT observations on pairs of request and reply packets, including packet exchanges during connection

²The lower bound of 300 milliseconds was chosen as appropriate for Ethernet.

```

/* The connection structure Conn contains:
   - the RTT-based lower bound LowerLimit
   - the maximum number of retries N
   - the keep alive interval Beta[0] and retry intervals Beta[1]... Beta[N]

   Calculate retry intervals Beta[1]...Beta[N+1] such that:
   - Beta[i + 1] = 2*Beta[i]
   - Beta[0] = Beta[1] + Beta[2] + ... + Beta[N+1]
   subject to the LowerLimit. */

long betax, beta0, timeused, i;

/* zero everything but the keep alive interval */
Conn->Beta[1] ... Conn->Beta[N] = 0;

/* recompute Beta[1] .. Beta[N] */
betax = Conn->Beta[0] / ((1 << Conn->N+1) - 1); /* shortest interval */
beta0 = Conn->Beta[0]; /* keepalive interval */
timeused = 0;
for (i = 1; i < Conn->N+2 && beta0 > timeused; i++)
{
    if (betax < Conn->LowerLimit) /* don't bother with (beta0 - timeused < LowerLimit) */
    {
        Conn->Beta[i] = Conn->LowerLimit;
        timeused += Conn->LowerLimit;
    }
    else
    {
        if (beta0 - timeused > betax)
        {
            Conn->Beta[i] = betax;
            timeused += betax;
        }
        else
        {
            Conn->Beta[i] = beta0 - timeused;
            timeused = beta0; /* we're done */
        }
    }
}
betax = 2 * betax;
}

```

Figure 3.1: Calculating RPC2 Retransmission Intervals

This figure shows how RPC2 calculates its retransmission intervals in pseudocode.

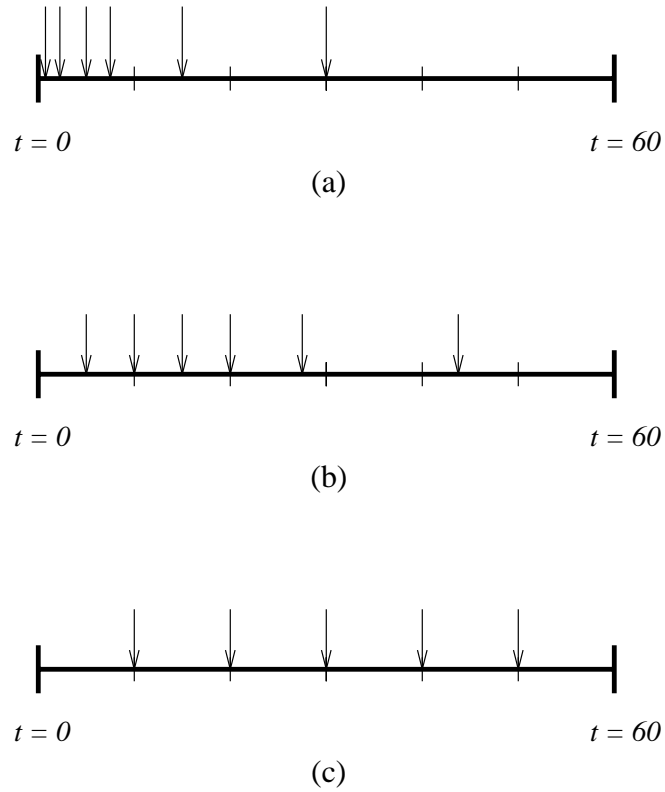

Figure 3.2: RPC2 Retransmission Intervals

This figure illustrates how RPC2 adjusts its retransmission intervals. Part (a) illustrates the initial retransmission schedule for $N = 6$ and $B_t = 60$ seconds. The arrows show when retransmissions are sent during the period B_t after the original request. If the retransmissions fail to provoke a response from the server, the client times out at B_t . In part (b), the retransmission schedule is adjusted according to a round trip time estimate of 5 seconds. The estimate serves as the lower bound on the retransmission interval. Part (c) shows adjustment with a lower bound of 10 seconds. In this case N is decreased to 5.

establishment. RPC2 uses a *packet timestamping* scheme, similar to that in recent versions of TCP [54, 99]. The RPC2 client stamps an outgoing packet with the current time, and the server echoes the timestamp on the next packet back to the client. The client computes the RTT observation by subtracting the echoed stamp from the current time.

Packet timestamping requires additional data to be sent on each packet – space that is at a premium in weakly connected environments. An earlier approach used for collecting RTT observations that did not require sending additional data on packets simply had the sender measure the elapsed time between the send of the data and receipt of the acknowledgement. Unfortunately, this scheme suffers from *retransmission ambiguity* – if the packet was retransmitted, with which send should an acknowledgement be associated? While there are strategies for alleviating retransmission ambiguity [57], they involve discarding observations contaminated by retransmissions. In contrast, observations collected using packet timestamping are unambiguous. As long as the timestamps are small, the ability to collect observations outweighs the space expenditure.

Round trip times are end-to-end measures that reflect not only switching and propagation delay within the network, but also send and receive processing overheads at the endpoints. The intent of the RTT measurements is to capture network delay, which is both significant for the range of networks under consideration and often highly variable [79, 109]. Thus the measurements exclude RPC queuing and service times, which are strongly dependent on request type and server load. Lengthy RPCs are addressed by the keepalive mechanism. Protocol processing overheads remain a part of the RTT measurements. However, with the advent of gigabit networks, attention has been focused on reducing these overheads [20, 34, 60, 65].

RPC2 timestamps are 32 bits long. The RPC2 packet header contains two timestamps. RPC2 uses one timestamp field for collecting RTT observations. It uses the other field to send the time for the bind sequence to the server. The bind time is used to initialize side effects. Timestamps are relative to RPC2 initialization; they are not synchronized between client and server. The resolution of the timestamp is 10 msec, which is comparable to the clock resolution (16 msec) on workstations currently in use. This resolution is coarse enough to allow an RPC2 application to run for over a year before the timestamp wraps around, yet fine enough to yield useful measurements for exchanges even over LANs.

RPC2 writes and collects timestamps to exclude queuing time from the RTT observation, and an RPC2 server excludes service time by adding it to the echoed timestamp before sending it back to the client, as shown in Figure 3.3(a). Retransmitted packets are stamped with the time of the retransmission, not the original send time. Busy packets echo the request timestamp; the service time is assumed to be zero, as shown in Figure 3.3(b). The minimum RTT is one unit (10 msec); an exchange that completes within a clock tick at the client yields an observation with the minimum value. Packets containing null timestamps are not used for calculating RTT observations. Such packets can result from erroneous requests and rejected binds.

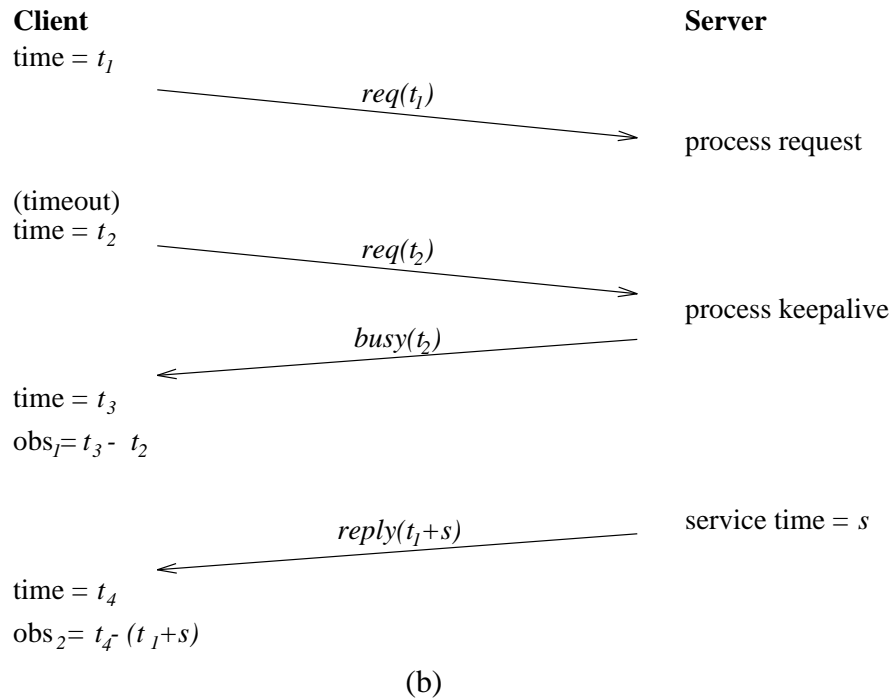
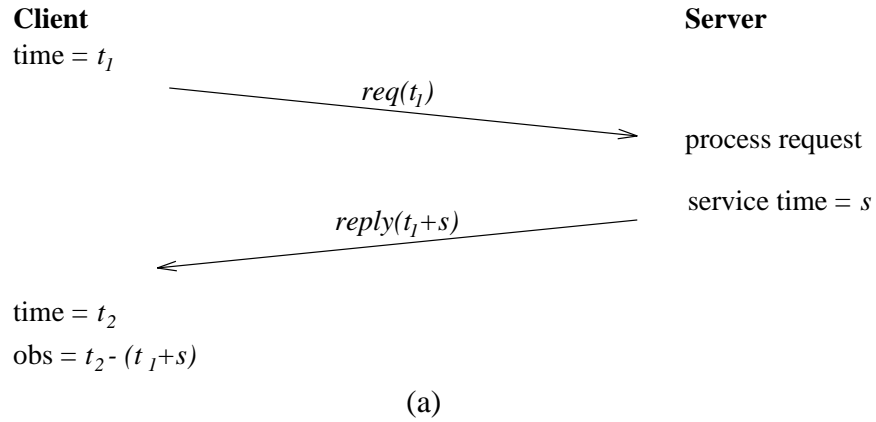

Figure 3.3: Collecting RTT Observations

This figure shows how RPC2 gathers RTT observations. Part (a) shows the common case. The server stores the timestamp on the request packet, and returns the timestamp plus the service time on the reply packet. The observation is calculated based solely on the current time and the timestamp in the received packet. Part (b) shows a timeout and retransmission. In this example, the client gathers an additional observation from the returned busy packet.

3.2.2.2 Estimating Round Trip Time

The RTT estimate is computed from the observations using a weighted average

$$RTT_{i+1} = \alpha RTT_i + (1 - \alpha)s_i \quad (3.2)$$

where s_i is an RTT observation. This estimate is referred to as the “smoothed RTT”. The choice of α determines how quickly the smoothed RTT responds to changes in the RTT observations. In RPC2, $\alpha = .875$, as recommended by Jacobson [52].

The retransmission timeout (RTO) is based on the RTT and an estimate of the variance, to adapt to the variance in delay seen from networks under high load [14]. The timeout is

$$RTO = \sigma RTT \quad (3.3)$$

where σ is the estimate of the variance, as calculated by Jacobson [52]. The RTO is then used as a lower bound on the retransmission intervals B_i .

RPC2 does not currently take request and reply length into account in its RTT estimate. Unlike in a file transfer protocol, the amount of data sent on requests and replies is not constant, nor even predictable. Because of this, the RTT has high variance at low bandwidths. To improve performance, the calculation of the RTO may need to take packet length into account [79]. Ideally, RPC2 would derive an RTT independent of length, then apply it given the length of the request and probable length of the reply. The RTO would be calculated using $ax + b$, where x is the packet size and b is the round-trip time for a zero-length request. One can approximate b with small packets. Then for larger requests, apply a as a correction factor to take network bandwidth into account.

3.2.3 Sharing Liveness Information

As mentioned earlier, the RPC and side effect protocols are isolated from each other, communicating only at well-defined points. While this separation makes the code extensible, it can cause unnecessary network traffic. While a side effect is in progress, the RPC layer may retransmit the request because its RTO has expired. On a high-bandwidth network this behavior is not a problem – the server simply responds with a busy packet. However, at low bandwidth, the network may be so congested with side effect traffic that the retransmitted request may not even arrive at the server before the client times out and declares the request failed.

To address this problem, RPC2 allows the RPC layer to query the side effect layer for liveness of its peer before retransmitting the request. If a side-effect packet has been received from the peer within the retransmission interval, the RPC layer suppresses the retransmission and operates as if a busy packet arrived at that time. The next retransmission is scheduled for B_t after the last side effect response from the peer.

Note that while RPC2 can share liveness information with a side effect on a given connection, it cannot share liveness information between different RPC connections to the same server. The reason is that a client cannot distinguish between remote site failure and a lost request packet (i.e., a client cannot infer from liveness of one connection that the server received a request on another connection). The reason the RPC and side effect layers can share liveness information for a given request is that a client can infer from the execution of a side effect that the server received the request and is busy servicing it. Thus RPC retransmissions are unnecessary.

3.3 Bulk Data Transfer

RPC2 uses a sliding window protocol [125] called SFTP (Smart File Transfer Protocol) to perform bulk data transfer. SFTP was originally designed for use on a local area network. It used a fixed timeout interval with no backoff strategy, and aggressively resent all unacknowledged data at once on timeouts. Early experiments revealed that it failed to operate below 100 Kb/s for receive and 9.6 Kb/s for send. To operate over a range of networks, SFTP needed to take into account the performance of the network before retransmitting data. This section provides an overview of SFTP, and then describes the changes to SFTP needed to cope with weak connectivity. For more information on other protocol details, the interested reader should see [111].

3.3.1 Protocol Overview

An SFTP file transfer occurs as a side effect of a remote procedure call. Since the transfer of data may flow from RPC2 server or RPC2 client, the sender of the data is called the *source* and the receiver is called the *sink*. The protocol is *asymmetric*, in that clients and servers are not treated equally. An RPC2 client is typically a single-user workstation, but an RPC2 server may be expected to service many hundreds of clients. To preserve scalability, the server controls a file transfer whether it is the source or the sink.

A file transfer is basically a series of data and acknowledgement exchanges. The source sends a set of data packets and waits for an acknowledgement to arrive. SFTP uses *selective acknowledgements* [54, 125]; in addition to specifying the last consecutive packet received, they may also indicate which packets in a range were received. When an acknowledgement arrives, the source resends any packets that the sink did not receive, and the next set of data packets. The frequency of acknowledgements, the window size, and the amount of data sent in response to an acknowledgement are among the file transfer parameters that may be set by client and server at SFTP initialization.

The protocol's asymmetry manifests itself in how a file transfer is started, and in handling timeouts. If the source is the server, as in Figure 3.4, the transfer occurs as described above.

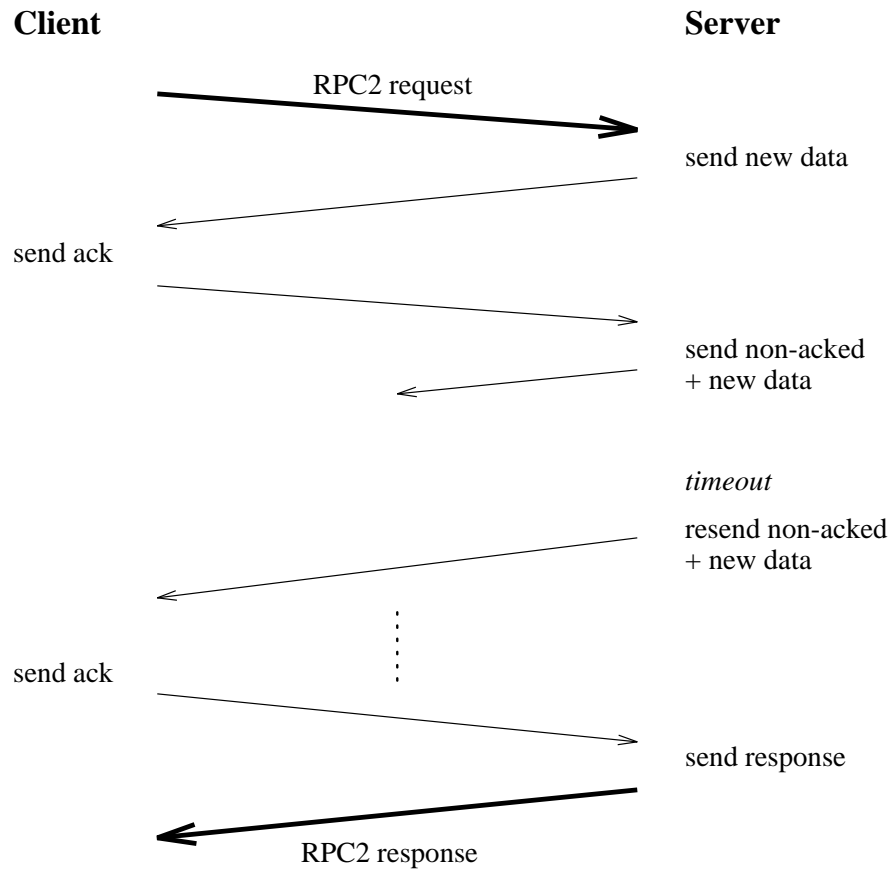

Figure 3.4: SFTP File Transfer: Server to Client

This figure shows a server to client SFTP file transfer. The server initiates the side effect after receiving the RPC request. It times out and retransmits data as necessary. When the transfer is complete, it sends the RPC reply to the client.

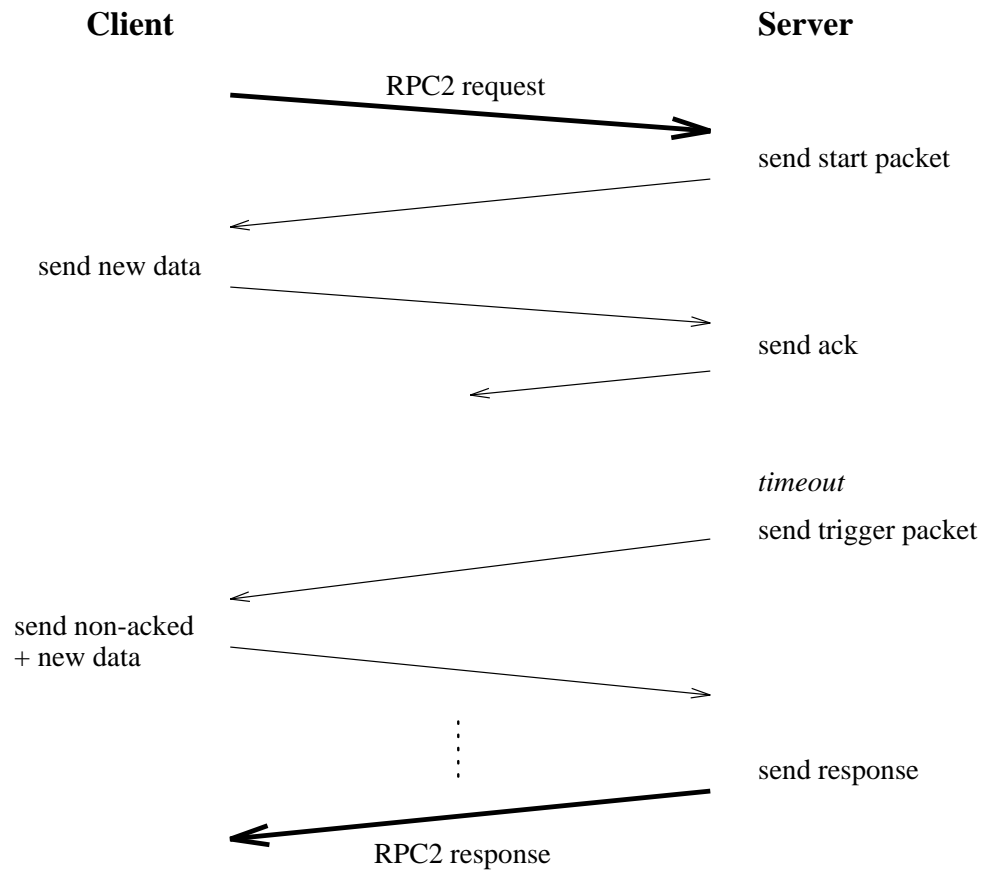

Figure 3.5: SFTP File Transfer: Client to Server

This figure shows a client to server SFTP file transfer. After receiving the RPC request, the server initiates the side effect by sending a start packet. The client then answers with the first set of data packets. The server controls retransmission by sending trigger packets, which signal the client to retransmit data.

If an acknowledgement does not arrive before a certain period has passed, the server times out and retransmits its packets. If the source is the client, as in Figure 3.5, data transfer begins only when the client receives a *start packet* from the server. After sending data, the client passively waits for an acknowledgement. It does not retransmit data upon timeout. Instead, the server times out and sends a *trigger packet*, which is a copy of the last acknowledgement.

3.3.2 Obtaining RTT Observations

Like RPC2, SFTP collects RTT observations using packet timestamps. The timestamps and storage of RTT state is the same as presented in Section 3.2.2. The use of packet timestamps in SFTP to gather RTT observations at the source is similar to that of TCP [54]. However, because of the asymmetry of SFTP, the sink also gathers RTT observations. If the sink is an RPC2 server, it may control the transfer even though it does not send data. Thus it must also gather RTT observations and derive its own RTO.

In SFTP, timestamping is *two-way*, allowing both source and sink to collect RTT observations during a transfer. The packet header contains two timestamps: the current timestamp, which is the time at which the packet was sent; and the echoed timestamp, which was generated by and returned to the receiver. Both the source and the sink keep an additional word of state to hold the timestamp that will be echoed next. Packets with null timestamps are not used for RTT observations. Retransmitted packets are stamped with the time of the retransmission, not the original send time. Packets retransmitted upon timeout echo null timestamps. These packets are sent by the server, and can be data (if server = source) or triggers (if server = sink). These packets do not represent real observations because they are generated spontaneously, not in response to a transmission from the client.

The measurements collected by source and sink are not equivalent, and only the sink measures what could be considered a true packet round trip time. The purpose of the measurements is to determine when to retransmit. Thus, the measurement of interest for the sink is the time for a start, acknowledgement, or trigger packet to be sent and a data packet received from the source. As shown in Figure 3.6, the source echoes the timestamp on data packets sent to the sink, and marks the first packet it sends in response to an acknowledgement. (The source must mark this packet because it is not necessarily the first packet in the receive window at the sink.) The sink computes the RTT based on the echoed timestamp in the marked packet. If the marked packet is lost, the sink may be able to calculate an RTT based on its retransmission. If the marked packet is delayed, the RTT will reflect the delay.

The measurement of interest for the source is the time for a set of data packets to be sent and an acknowledgement received. The source timestamps each data packet in the set. The sink retains and echoes the timestamp from the earliest unacknowledged packet, which is the

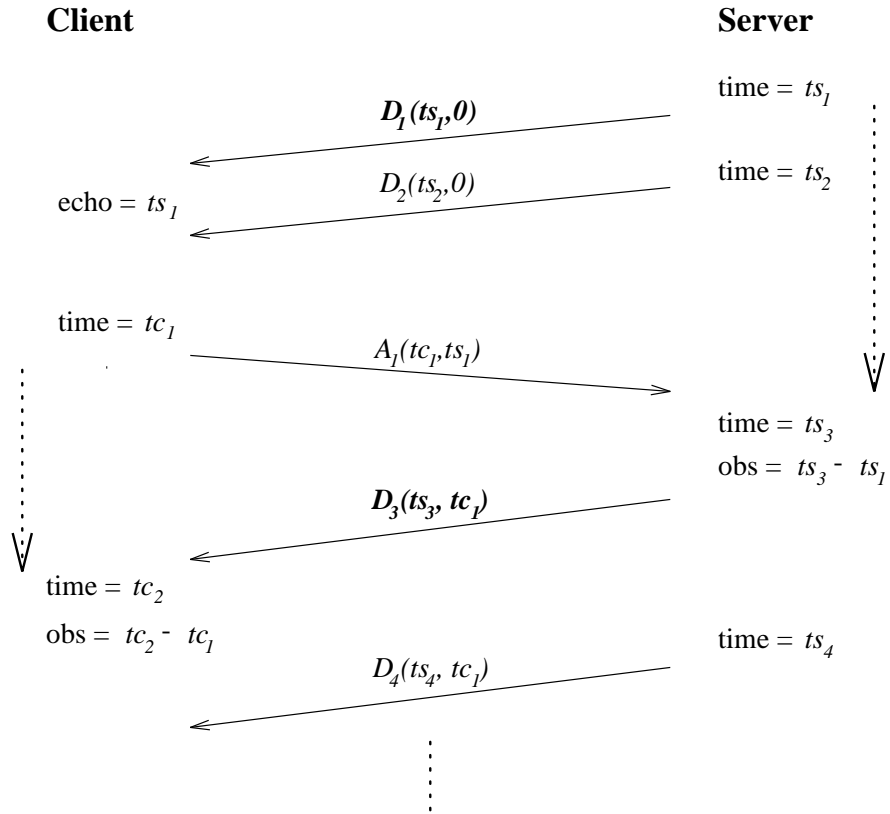

Figure 3.6: Two-way Timestamping in SFTP

This figure illustrates an SFTP packet exchange with the server as the source. The server times data-to-acknowledgement exchanges, and the client times acknowledgement-to-data exchanges, as shown by the dotted vertical arrows. In this transfer, acknowledgements are requested every other packet. The first data packet of each set is marked, and is shown in bold. Since time is measured relative to RPC2 initialization, client and server timestamps are not synchronized. Client timestamps are denoted tc_i and server timestamps are denoted ts_i . When D_1 arrives, the client retains its timestamp ts_1 to echo on the next acknowledgement. There is no RTT observation to compute from D_1 because its timestamp is null (i.e., the file transfer has just started). The server computes an RTT from A_1 when it arrives based on ts_1 . When D_3 arrives, the client computes an RTT observation from its echoed timestamp tc_1 .

packet at the left edge of its receive window³. If the left-edge packet arrives before the sink sends the next acknowledgement, regardless of its arrival order within the set, its timestamp will be echoed to the source. If the left-edge packet does not arrive before the sink sends the next acknowledgement, the sink has several options:

1. Echo the timestamp from the packet that most recently advanced the left edge of its receive window. This timestamp may be older than the one on the left-edge packet, and may result in a larger RTT.
2. Echo the timestamp from the earliest of the received packets. This timestamp may be newer than the one on the left-edge packet, and may result in a smaller RTT.
3. Echo a zero timestamp. The RTT estimate at the source will remain unchanged.

RPC2 uses the first option; the sink echoes the older timestamp. If packets are delayed or lost, the source should be more conservative about retransmission. If the left-edge packet is delayed and arrives eventually, the timestamp echoed to the source will reflect the delay. If the left-edge packet is lost, its retransmission will contain a more recent timestamp. The resulting RTT observation will be based on the newer information. When the acknowledgement arrives at the source, the source computes the round trip time for the set of packets based on the echoed timestamp.

3.3.3 Estimating RTT

The smoothed RTT and RTO are derived from the RTT observations as in Equations 3.2 and 3.3. Note that during a file transfer, the source and sink usually have different smoothed RTTs and therefore different RTOs. The RTT on the source is a measure of the time to send some number of data packets and receive an acknowledgement. In contrast, the RTT on the sink is a measure of the time to provoke a response (i.e., a data packet) from the source. The two RTTs are equivalent only if the source requests an acknowledgement on every packet.

When a new connection is established the RTT state is initialized at the client using observations from the RPC2 bind sequence. This information is also sent to the server on the first request on the connection to initialize its SFTP RTT state.

3.3.4 Retransmission Strategy

SFTP uses an adaptive, RTT-based retransmission strategy with exponential backoff. The retransmission timer is separate from the smoothed RTT estimate. When the retransmission timer is backed off, RTT observations may still be collected.

³The left edge of the receive window is advanced as necessary when an acknowledgement is sent.

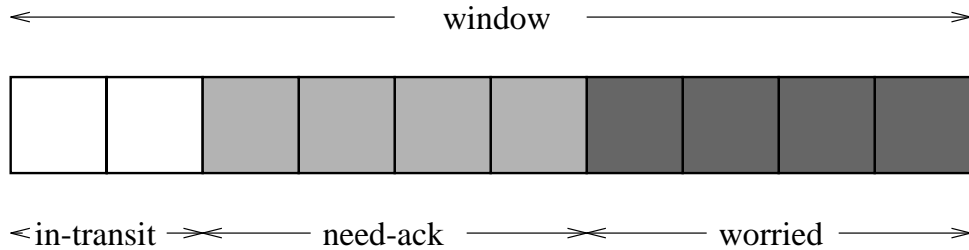

Figure 3.7: SFTP Packet Sets

This figure illustrates SFTP packet sets for a window of ten packets, where acknowledgements are requested every four packets. Packets on the left were sent most recently. Packets for which an acknowledgement has been requested but not received and the RTO has expired are in the worried set. Only these packets are retransmitted. Packets for which an acknowledgement has been requested but not received and the RTO has not yet expired are in the need-ack set. Packets for which an ack has not yet been requested are in the in-transit set.

In the original version of SFTP, the retransmission strategy was as follows: data packets sent by the source and for which an acknowledgement had been requested but not received were placed in a *worried* set. If the source was an RPC2 server, all of the packets in the worried set would be resent upon timeout, followed by the next set of data packets. If the source was an RPC2 client, the packets above would be sent upon receipt of a trigger. If the window became full, only the first packet in the worried set was sent.

The problem with this strategy for slow networks is that a source becomes worried about a packet the instant it is sent. The key change to this strategy is to delay worrying about a packet until after at least a round trip time interval. The worried set is now partitioned into two sets – the *need-ack* set and the *worried* set, as illustrated in Figure 3.7. Packets in the need-ack set have been sent and an acknowledgement has been requested, but not enough time has passed to be worried about the fact that an acknowledgement has not been received. Packets are moved to the worried set when the RTO expires. Only packets in the worried set are retransmitted.

3.4 Exporting Network Information

How should RPC2 convey information on network performance to higher levels of the system? Different applications may use the information in different ways. For example, they may differ in how they average the observations, how recent the observations should be, and how many samples are taken during any one interval. The form of the information should be flexible

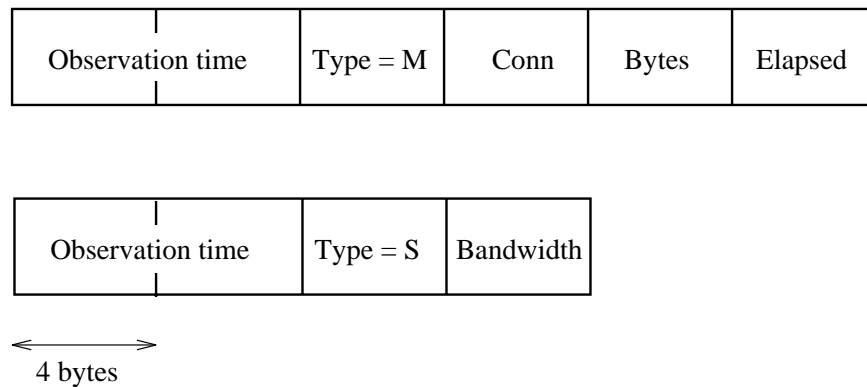

Figure 3.8: Transmission Log Record Formats

A transmission log may contain records of different types. Currently there are two record types, the measured record (M) and the static record (S). The timestamp contains the system time (8 bytes). The measured record contains the connection identifier, number of data bytes, and elapsed time in milliseconds. The static record contains the nominal bandwidth.

enough to satisfy different application requirements. RPC2 exports two kinds of performance information – *liveness* and *transmission logs*.

3.4.1 Liveness

Liveness refers to the last time a packet was received from a $\langle \text{host, portal} \rangle$ pair. Since RPC2 does not send keepalives between requests, applications must probe their peers to detect site failures. Exporting liveness information allows applications to suppress probes. RPC2 tracks liveness for each $\langle \text{host, portal} \rangle$ pair, independent of connection. Applications can query RPC2 for the liveness of a connection's peer and its side effect, if any:

```
RPC2_GetPeerLiveness(ConnId, Time, SETime)
```

The times returned are those of the last receipt from the host and portal and its side effect, on any connection. These times reflect the liveness of the process reachable at that endpoint. They do not convey any information about a specific request, and as explained in Section 3.2.3, they cannot be used in that way. In particular, RPC2 keepalives can occur even in the presence of high-level deadlock.

Timestamp	Type	Conn	Bytes	Elapsed
822938159.257492	M	1245277	11200	90
822938159.335613	M	1245287	11200	150
822938159.366871	M	1179726	11200	170
822938159.429364	M	1245277	11200	180
822938159.616868	M	1179726	7180	120

Figure 3.9: Transmission Log

This figure shows a fragment of a transmission log written by SFTP. The records shown are all of the measured type, and represent observations from three different connections. The bytes field is the number of data bytes involved in the exchange. The elapsed time shown is in milliseconds.

3.4.2 Transmission Logs

Transmission logs contain recent observations of network performance. A transmission log is a fixed length circular buffer⁴ containing a series of timestamped records. A transmission log is associated with each $\langle \text{host, portal} \rangle$; observations from different connections are multiplexed onto the same log. Side effects maintain separate transmission logs.

Transmission log records may be of two types, as shown in Figure 3.8. The *measured* log record contains measurements of an exchange between client and server. Connections are distinguished by connection identifier. The bytes field refers to the amount of application data involved in the exchange, not protocol overheads such as packet headers. The elapsed time field is measured in milliseconds. A fragment of an SFTP transmission log containing measured records is shown in Figure 3.9. The *static* log record allows incorporation of externally-supplied static information, such as the nominal bandwidth of the network connection. This record could easily be expanded to include additional static performance measures, such as latency and cost.

There are three RPC2 calls pertaining to transmission logs.

```
RPC2_GetNetInfo(ConnId, RPCLog, SELog)
RPC2_PutNetInfo(ConnId, RPCLog, SELog)
RPC2_ClearNetInfo(ConnId)
```

⁴The default log size is 32 entries. At this size, a log and accompanying data structures within RPC2 amount to 820 bytes per $\langle \text{host, portal} \rangle$ pair. This is acceptable even for a server with connections to thousands of clients.

An application may obtain RPC or side effect transmission logs for the peer of a connection using the `RPC2_GetNetInfo` call. The last two calls allow an application to modify a transmission log. `RPC2_PutNetInfo` allows an application to add log records. This facility is useful for depositing static estimates obtained at the application layer. Finally, `RPC2_ClearNetInfo` clears a transmission log. This call allows applications to cope with drastic changes in connectivity, such as if the client switches between network connections with significantly different performance characteristics.

3.4.2.1 RPC2 Log Records

An RPC2 client writes a transmission log record when it updates the RTT as described in Section 3.2.2.1. Although RPC2 servers do not write log records, a transmission log is associated with each peer because a process may be both an RPC2 client and an RPC2 server.⁵ A record at client C in the transmission log for server S means:

C and S exchanged B bytes of data between time t_s and time t_r .

where B is the amount of actual user data transferred (not packet headers or duplicates), t_s is an echoed packet timestamp (suitably converted), and t_r is the current time when the client writes the log record. The log record then contains t_r as the observation time, B as the data amount, and $(t_r - t_s)$ as the elapsed time. For RPC2, the elapsed time is exactly an RTT observation, and the byte count is the sum of the data amounts on the request and reply packets. RPC2 writes log records for exchanges of packets during the bind sequence, as well as exchanges of keepalives and busy packets. Since most RPC request and reply packets are small, RPC log entries may be used as measures of end-to-end latency.

3.4.2.2 Side Effect Log Records

Side effects define the meaning of their log records. In SFTP, log records are measures of effective network throughput for bulk transfer. For large files or weak connections, bulk transfers may be lengthy. Rather than wait until the transfer completes to measure effective throughput, SFTP measures exchanges of data and acknowledgement packets. Both the source and the sink write SFTP log records. A record at host H_1 in the SFTP transmission log for host H_2 means:

H_1 and H_2 transferred B bytes of data between time t_s and time t_r .

⁵An example occurs in Coda: Venus is a client of Vice for file system requests, and Vice is a client of Venus for callbacks.

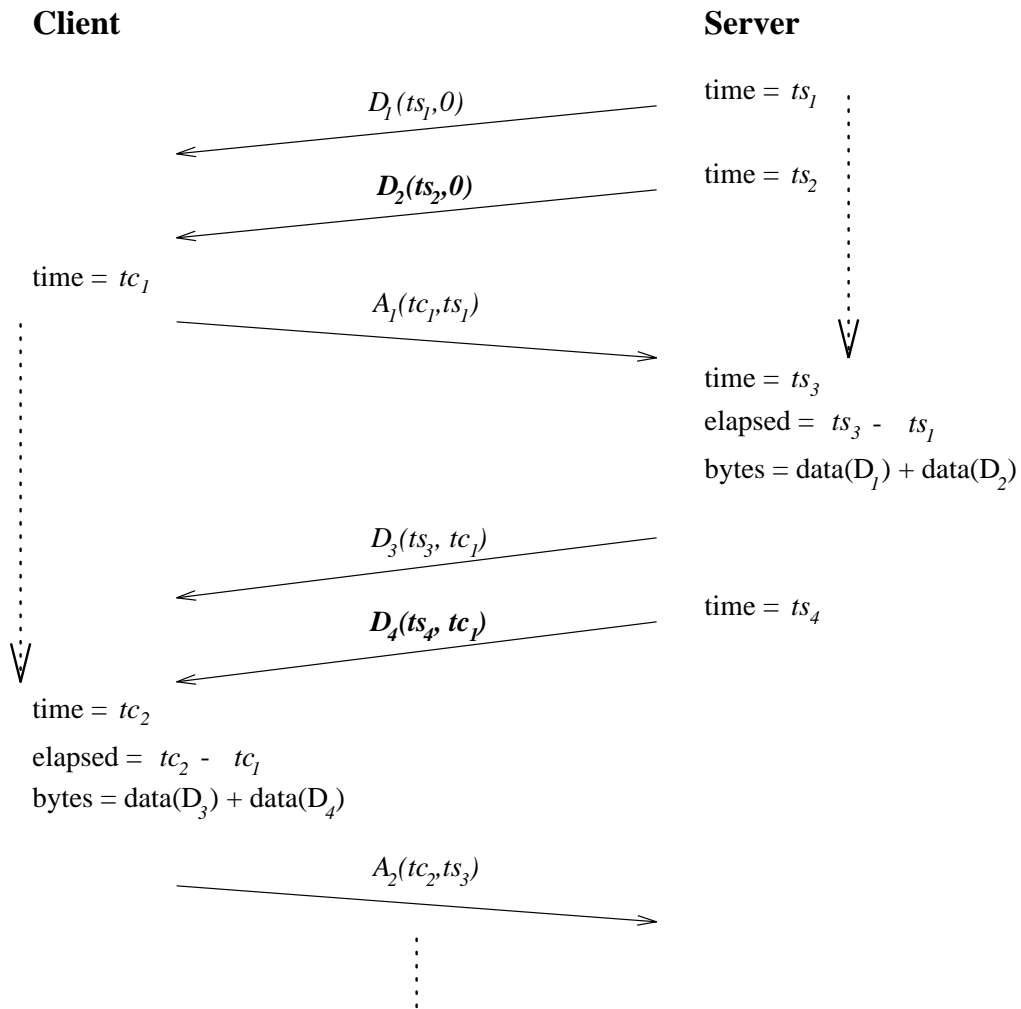

Figure 3.10: Measuring SFTP Rounds

This figure shows how information for SFTP log records is collected during a file transfer. In this example, the server is the source and the client is the sink. Acknowledgements are requested every other packet, as shown in bold. The rounds measured are shown with dotted vertical arrows. The server writes a log record when A_1 arrives acknowledging D_1 and D_2 . The elapsed time is based on ts_1 echoed on A_1 . The byte count reflects the packets acknowledged by A_1 , not those sent by the server, though in this example they happen to be equivalent. The client writes a log record when packet D_4 marked for acknowledgement arrives. The elapsed time in its record is based on the echoed timestamp tc_1 , which is the time the sink sent the most recent acknowledgement received by the server. The byte count reflects the new data acknowledged by A_2 , namely D_3 and D_4 .

where B is the amount of actual user data transferred (the direction depends on which host is the sink), t_r and t_s are times measured at H_1 , t_r is the observation time, and $t_r - t_s$ is the elapsed time. In other words, the data is known to have been sent and received between t_s and t_r .

SFTP writes log records based on the packet timestamps used for measuring round trip times as described in Section 3.3.2. To measure elapsed time, the source measures the time from sending the first data packet to receiving the acknowledgement. As shown in Figure 3.10, it writes a log record when an acknowledgement packet acknowledging new data arrives. The echoed timestamp on the acknowledgement is t_s , and the resulting elapsed time is equivalent to an RTT observation as described for the source in Section 3.3.2. The sink measures the time from sending the acknowledgement to receiving a data packet marked for acknowledgement. It writes a log record when a new data packet marked for acknowledgement arrives. The echoed timestamp on this data packet is t_s . In Figure 3.10, the server logs a record when A_1 arrives, and the client logs a record beginning when D_4 arrives.

To measure effective throughput, SFTP must guarantee that the byte count in each record reflects only the new data actually sent and received between t_s and t_r . The byte count in a log record includes data on packets that satisfy the following conditions:

1. The packets are in the transmit window (source) or receive window (sink).
2. The packets are acknowledged by the acknowledgement (source) or are about to be acknowledged (sink).
3. The packets have not been recorded previously.
4. The packets have timestamps no earlier than the echoed timestamp.

Conditions 1 and 2 exclude duplicate packets. Condition 2 ensures only those packets known to have been received are recorded. Since acknowledgements are cumulative, condition 3 prevents overcounting of packets that are still in the window and have already been included in a log record. Packets are marked when recorded to detect this condition. Packets must be acknowledged to be recorded, but are not necessarily recorded if acknowledged. Note that these conditions do not preclude use of spontaneous retransmissions by the server, as in RTT estimation. Log records may be written at the client as long as the retransmission by the server either generates new data or acknowledges new data.

Condition 4 is necessary because packets may be lost or delayed. Consider the example in Figure 3.11, in which losses and retransmissions cause an acknowledgement to acknowledge more data than was sent to provoke it. The source sends data packets, and the acknowledgement is lost. The source times out and retransmits, and sends enough new data to fill its transmit window. The acknowledgement is again lost. The source times out again, sending the first unacknowledged packet in the transmit window. It finally receives a response, acknowledging receipt of all data. What should the source log record say? It cannot include all of the data

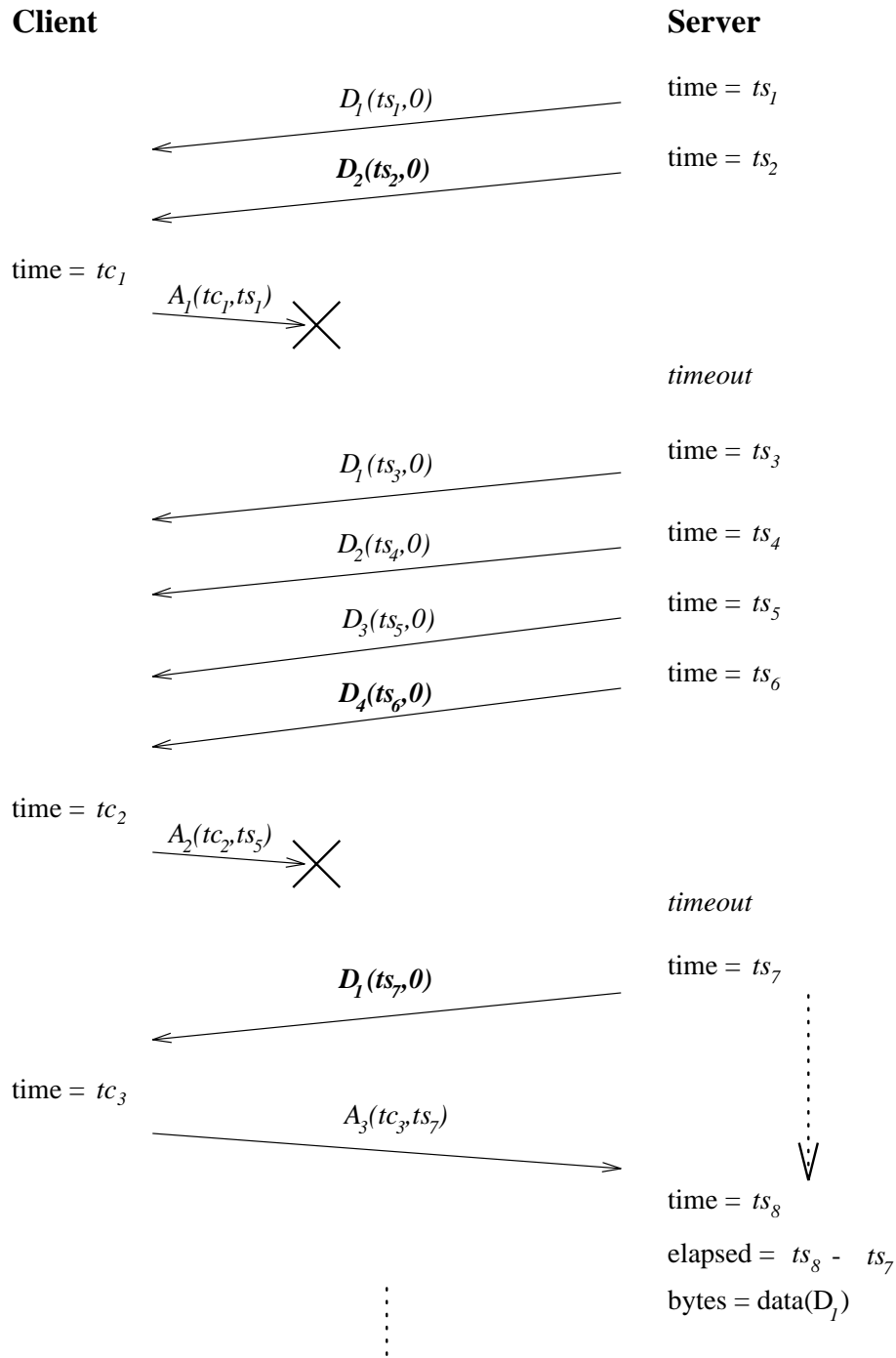

Figure 3.11: SFTP Records and Retransmission

This figure shows how observations for SFTP log records are collected if retransmissions occur. In this example, acknowledgements are requested every other packet, and the transmit window is four packets. Packets marked for acknowledgement are shown in bold. The source writes a log record when A_3 arrives. The byte count reflects only those packets in the transmit window sent no earlier than echoed timestamp ts_7 , namely D_1 . For A_2 , recall from Section 3.3.2 that the sink echoes the timestamp for the leftmost packet in its receive window. Since D_1 and D_2 have already been received, it the sink echoes ts_5 from packet D_3 .

acknowledged, because most of it was sent before ts_7 . Fortunately, one can determine which packets are to be included by comparing the timestamp echoed on the acknowledgement (t_s) to the timestamps on the packets in the transmit window. Packets with earlier timestamps are excluded from the log record. Should an earlier acknowledgement arrive after much delay, such packets may be logged at that point.

A similar situation can occur if packets are delayed. For example, suppose in Figure 3.10 that packet D_1 arrives at the sink after D_2 . When D_4 marked for acknowledgement arrives, what should the sink log record say? It cannot include packet D_1 , because the packet was not sent in response to A_1 ; the sink cannot prove that it was sent between tc_1 and tc_2 .

The conditions above guarantee data is logged at most once, and only during an interval in which it was sent and received. If packets are lost or delayed, condition 4 implies that data may not be logged at all. For example, in Figure 3.11, the data on packets $D_2 - D_4$ is not included in the source log record. Unfortunately, in the absence of an earlier acknowledgement, not enough is known about the timing of earlier packets to log accurate elapsed times for them, even in separate records. The issue is one of retransmission ambiguity. Consider packet D_2 . If its original send time is used, the elapsed time may be an overestimate because the packet may have been lost. If the most recent send time is used (i.e., the packet timestamp), the elapsed time may be an underestimate because the acknowledgement may reflect receipt of an earlier transmission. SFTP does not log records for the earlier packets, and thus may undercount the amount of data transferred.

3.4.3 Application Uses

Venus uses both liveness information and transmission logs. Liveness information is used to suppress *server probes*, which are RPCs that Venus periodically sends to servers to detect state changes⁶. If Venus is connected to a server over a heavily loaded weak link, a probe may fail, causing Venus to declare the server down. This behavior can cause communication on other connections to the same server (e.g., a file transfer) to fail unnecessarily. To avoid this situation, Venus uses liveness information in lieu of probes. If a server was heard from within a probe interval, Venus pretends it probed the server successfully at that time.

Venus uses the SFTP transmission logs to calculate bandwidth estimates for each server, using a weighted average as in Equation 3.2. Venus polls RPC2 periodically to harvest new measurements and update its estimates, and uses a simple threshold to determine if it is weakly connected with respect to a server. While weakly connected, bandwidth estimates are used to influence cache miss handling (Chapter 6) and trickle reintegration (Chapter 5).

Bandwidth estimates can become stale, because they are only collected during file transfer. While weakly connected, file transfers can be less frequent for a variety of reasons. For

⁶Venus probes up servers every 12 minutes, and down servers every 4 minutes.

example, CML optimizations reduce the amount of data sent to the server during reintegration, compared to the amount for the same updates performed while strongly connected. Users can reduce the amount of data received from the servers by deferring demand fetches, and by controlling the amount of data fetched during hoard walks. If Venus relies solely on file transfer for its estimates, it may not detect improvements in network performance promptly while weakly connected.

There are two strategies for dealing with stale estimates: generate test traffic, or find another source of traffic to monitor. The former approach involves declaring an estimate suspect after a certain period, and going forth in search of new information. Venus uses the former approach in an indirect way. If an estimate is not updated within a certain period, Venus optimistically declares the connection strong. If the connection is still weak, Venus will discover that fact on the next file transfer. The staleness threshold should be large enough to prevent gratuitous transitions between strong and weak connectivity, and to allow background processes that might transfer data (e.g., hoarding and trickle reintegration) to occur. The threshold could also be made dependent on worker idle time within Venus to prevent test transitions while a user is actually working.

The second approach involves finding a source of fresh information without generating any additional traffic. While weakly connected, Venus still sends server probes. Thus the RPC transmission logs are refreshed at least once every probe interval. It remains to be seen if the measurements in the RPC transmission logs are sensitive enough to reliably detect crossings of the weakly connected threshold.

Venus also deposits static estimates into the transmission logs in response to application-supplied bandwidth hints. For example, some Coda users run a configuration script on their notebook computers to change the primary network interface, such as from a wireless LAN interface at the office to a SLIP interface when dialing in from home. Drastic changes in network performance are virtually guaranteed when these interface changes occur. The network configuration script supplies Venus with the nominal bandwidth associated with the new interface. Venus then clears the transmission logs associated with each server, and writes into each a static log record containing the nominal bandwidth. Bandwidth hints may be sent to Venus from the command line using `cfs`, or from a program through the `pioctl` interface.

An artifact of the user-level library implementation of RPC2 is that monitoring is distributed among applications. There is no facility for sharing measurements between applications, and each application must discover network performance characteristics independently. Since Venus is long-lived and is often the primary source of network traffic, these are not serious drawbacks.

3.5 Effects of Server Replication

Venus normally makes requests on replicated objects, which requires that it communicate with a group of servers (the AVSG) instead of a single server. Most of the work for replication is performed at the Coda client. Venus must coordinate execution of RPCs to the AVSG and determine connectivity with respect to the AVSG as a whole.

3.5.1 MultiRPC

Venus uses the MultiRPC extension to RPC2 [117] to make requests to groups of servers in parallel. This extension is layered entirely on the client side implementation of RPC2. Individual request packets are sent to each server sequentially on separate RPC connections. Servers respond as they would normally; the request packets are indistinguishable from those sent by a single server RPC.

MultiRPC transmissions on different connections can interfere with each other if connectivity is weak and packets are large, or if multiple file transfers are in progress. Multiple simultaneous transfers occur not only as a result of independent requests, but more commonly as a result of store and reintegration operations to an AVSG. The implementation makes no special provision for this interference; competing connections time out and adjust their retransmission intervals as necessary. However, this approach may not be sufficient in view of simulation studies of multiple TCP connections over bottleneck links [120, 131]. These studies predict phenomena such as clustering of packets by connection, and “ack compression”, which thwarts the ability of a sliding window protocol to regulate its send rate.

An obvious way to alleviate interference between connections during a MultiRPC is to use multicast, and an early version of Coda [114] used a prototype implementation of IP multicast [31] over a single Ethernet segment. Multicast addresses were associated with VSGs. Venus supplied the unicast connections and multicast information for each RPC. MultiRPC multicasted the initial transmission, and then unicasted retransmissions as necessary. Reviving this support in an internetwork setting would involve changes to device drivers and an update to the existing IP implementation. The RPC2 RTT collection and transmission log code would also have to be revisited. Since packet loss vitiates the effectiveness of multicast in reducing interference, the unicast retransmission strategy may also require modification. In addition, gateways would have to be tested to ensure multicast packets are handled correctly, and multicast routing would have to be performed on the appropriate networks. Finally, Coda’s reintegration mechanism would require modification to take advantage of multicast support; currently new file data is fetched by each server through a server-to-client RPC on a separate connection, rather than sent from client to servers. Instead, Coda uses a combination of the reintegration and resolution mechanisms to minimize the amount of data sent over the weak

connection while propagating updates to all members of the AVSG. This issue is discussed further in Chapter 5.

3.5.2 Connectivity to an AVSG

For replicated volumes, Venus must determine the connectivity to the AVSG rather than a single server. The bandwidth estimates for AVSG members are not necessarily equal, and one cannot assume there is a single bottleneck link between the client and the AVSG⁷. If bandwidth estimates show some members are weakly connected and others are strongly connected, what is the connectivity to the AVSG?

Venus considers an AVSG weakly connected if any of its members are weakly connected. The reason for this is that update performance is determined by the slowest server. Once the volume is weakly connected, updates are logged and propagated to server asynchronously. This strategy is somewhat pessimistic for fetches, because data is transferred from only one server. However, one can arrange to fetch data from the AVSG member with the best estimate.

3.6 Quality of Service

An underlying assumption of Coda's communications layer is that the network is completely unhelpful – it neither makes guarantees nor provides feedback regarding the quality of service (QoS) it offers; it simply delivers data in a best-effort manner. The communications layer described in this chapter essentially derives QoS information empirically. Recent work towards supporting real-time distributed applications, such as video players, allows applications to request a certain QoS from the network [15, 19, 38, 118, 130] or the operating system [23, 77, 90]. If the system accepts the request, it may make guarantees or offer feedback on the quality of service. For example, it may promise to notify the application if the quality of service changes significantly.

How would QoS support change the existing communications layer? If such support were available, the communications layer could take advantage of it in a number of ways. For example, SFTP could adjust its retransmission strategy based on the packet loss rate. RPC2 could reduce the frequency of round trip time measurements depending on the presence and strength of a latency guarantee. However, the mechanisms for end-to-end measurement should remain for two reasons.

⁷Initial experiments with bandwidth estimates revealed performance differences correlated with which Ethernet segment a Coda server was attached. Two VSGs of three servers each were split over a private facilities network and a busy public network. The bandwidth estimates for servers on the public network were, on average, less than half the estimates for servers on the private network.

First, they allow broadest possible use of the system. Not all systems offer QoS support, and for those that do, there is no standard way to specify QoS. Parameters vary – common ones are bandwidth, latency, jitter, and loss rate. Parameter values also vary – for example, the bandwidth specification may be a peak value, an average value, or a range of acceptable values. Having specified QoS, there are no standard service guarantees. The system may offer a deterministic (hard) guarantee, a statistical (probabilistic) guarantee, or no guarantee at all. The entity that offers the guarantee may also vary. Most research has focused on guarantees provided by the network, but there is also work on guarantees provided by the operating system.

Second, higher system layers could use end-to-end measurements to verify QoS guarantees or feedback provided by lower layers. Discrepancies may reveal bugs in QoS support or inefficiencies in intervening system layers. If there is a discrepancy, end-to-end measurements are a more accurate reflection of the QoS the application actually receives.

3.7 Chapter Summary

This chapter describes how the communication layer gathers information on network performance and exports it to applications, and how one application in particular, Venus, uses the information to adapt to network performance. The RPC and bulk transfer protocols employ a passive monitoring strategy that gathers measurements without expanding existing packet formats or generating additional network traffic. The protocols use adaptive retransmission algorithms based on round trip time estimation. A comparison of throughput with TCP is provided in Section 7.3. Measurements of network performance are exported to applications in a minimalistic and flexible way using *transmission logs*, which can incorporate both static and dynamic information. Applications use the measurements as they see fit in defining their criteria for weak connectivity. In addition to Venus, transmission logs have been used supply information on network performance to other adaptive applications, such a video player [90].

Chapter 4

Rapid Cache Validation

A distributed file system using weak connections must function in spite of limited bandwidth and intermittent connectivity. The usability of the system in such an environment depends critically on its ability to resynchronize state rapidly upon reconnection. For a distributed file system, the state of interest is the client file cache.

Callback-based cache coherence is invaluable for preserving scalability while maintaining a high degree of consistency. This technique is based on the implicit assumption that the network is fast and reliable. Unfortunately, this assumption is often violated in weakly-connected environments. When a client with callbacks encounters a network failure, it must consider its cached files suspect because it can no longer depend on the server to notify it of updates. Upon repair of the failure, the client must validate cached files before use. Consequently, as failures become more frequent, the effectiveness of a callback-based scheme in reducing validation traffic decreases. In the worst case, client behavior may degenerate to contacting the server on every reference. This problem is exacerbated in systems that use anticipatory caching strategies such as hoarding to prepare for failures. In these systems, validation traffic is proportional not just to the file *working set*, but to the larger *resident set*. The more diligent the preparation for failures, the larger the resident set. The impact of this problem increases as network bandwidth becomes precious.

The approach used to solving this problem is based on the observation that the vast majority of cached objects are still valid upon reconnection. In other words, the rate of remote updates to file system data cached at a client is lower than the rate of connectivity change, particularly in intermittent environments. The solution therefore increases the *granularity* at which cache coherence is maintained. Clients summarize the contents of their caches for the purpose of validation. This technique dramatically reduces reconnection latency, allowing clients to recover from failures more quickly.

This chapter presents the details of rapid cache validation in four parts. The first section discusses key design issues, such as the granularity at which coherence is maintained. Next

the cache coherence protocol is described. The third section discusses implementation details. The last section discusses correctness of the protocol.

4.1 Design

4.1.1 Choice of Granularity

Increasing the granularity at which cache coherence is maintained allows clients to quickly validate their caches after failures. But at which granularities should cache coherence be maintained? Taken to an extreme, this idea would require maintaining a version stamp and callback on the entire file system. If the version stamp remains unchanged after a failure, the client can be confident that no files have been updated on the server. A callback on the entire file system is a very strong statement – it means every file cached at the client is valid. However a callback break on the file system conveys little information – anything in the file system could have changed, whether cached at the client or not. A practical implementation of this idea requires a choice of granularity that balances speed of validation with precision of invalidation.

Coherence on a file-by-file basis requires the most communication for validation, because each file must be checked individually. Invalidation requires the least communication, because the only updated file is identified. This scheme is ideal on a fast, reliable network such as a LAN. Reliability implies few connectivity changes, which renders validation less frequent than invalidation. When validation is necessary, the high bandwidth of a LAN makes it unlikely to be the bottleneck. At the other extreme is coherence at the level of the entire file system. Validation requires the least communication, because the state can be checked with a single version number. But since invalidation occurs when any file in the system is updated, files unaffected by the update must be re-checked. Because of its lack of precision, invalidation in this scheme requires the most communication. The goal is to minimize communication by choosing a granularity appropriate for the validation and invalidation frequency.

The granularity chosen should partition the client's cache into a moderate number of groups. If there are too few groups, client performance will approach that of file-system-level coherence. Similarly, too many groups will result in performance close to that of file-level coherence. Each group should contain objects that are logically related and hence possess similar update characteristics. Grouping objects in this way maximizes the likelihood of successful validation.

The groups should be represented by concise, unique identifiers known to both client and server. The creation of this identifier should not require communication between client and server, or the enumeration of the objects it represents. This implies that a pre-existing partitioning should be used. To support rename without requiring the invalidation of descendants of the renamed object, the identifier must be invariant across name bindings.

An obvious approach is to exploit the hierarchical structure of the file name space. However, the considerations above, particularly with regard to group identifiers, preclude the use of pathname prefixes as units of coherence.

In addition to the above considerations, the desire for a simple implementation suggested only one level in addition to files: *volumes*. Volumes are attractive as units of coherence because they are typically created for individual users or projects and hence represent groups of files that are logically related. Volumes are represented by fixed-length identifiers known to both client and server. The identifiers are invariant across changes in mount points, and are conveniently embedded in all file identifiers.

4.1.2 Volume Callbacks

The system maintains cache coherence by using *volume callbacks* (VCBs). VCBs may be maintained in addition to or instead of file callbacks. The presence of a volume callback means all files cached from the volume are valid, and may be read with no client-server communication. In addition, the server will notify the client if any object in the volume is updated. Thus a volume callback may serve as a substitute for file callbacks.

Early analysis suggested that volume callbacks would be beneficial for collections of files owned by the primary user of a client, and for collections that change infrequently or change *en masse* (e.g., system binaries) [85]. Section 7.4 shows that such collections represent a large fraction of the files that users cache. Performance may be poorer with other workloads, but Coda's original cache coherence guarantees are still preserved.

4.2 Protocol Description

Coda summarizes volume state using *version stamps*, maintained at each server storing the volume. The version stamp is incremented when any file in the volume is updated. A client caches the version stamp, establishing a callback for the volume. The callback is actually on the version stamp. It means the client has cached files corresponding to the version of the volume designated by the value of the stamp.

Of course, the client must ensure that version stamps are consistent with the data they represent, and it must handle updates from other clients, which manifest themselves as callback breaks. The remainder of this section discusses these issues.

4.2.1 Obtaining Callbacks

To ensure that the files cached at the client correspond to the version stamp it receives, the client must validate all cached files from the volume before obtaining a volume version stamp. For volume callbacks to be effective, there must be more than one file cached from the volume. The process of obtaining a volume version stamp is illustrated in Figure 4.1.

If a failure occurs, the client must consider its cached files and volume version stamp suspect because the server may not have been able to notify it of updates. In Coda, this occurs when the AVSG grows. Upon reconnection, the client presents its version stamp to the server. If the stamps match, all of the client's cached data from the volume is valid, and the server grants a callback for the volume. The volume callback is a substitute for file callbacks on all the files in that volume. Figure 4.2 illustrates a successful validation. If the validation fails the client must rely on file callbacks, if present, or obtain them on demand.

If the client holds a volume callback and fetches a new file, the server establishes a file callback for the new file. This is not necessary for correctness, but it is useful for performance. Although one could imagine not establishing the file callback to conserve server memory, granting the file callback in this case requires no additional network communication, and gives the client something to fall back on should the volume callback be broken.

4.2.2 Handling Callback Breaks

When a file is updated by a remote client, the server breaks callbacks to all other clients holding a callback for that file or its volume. An example is shown in Figure 4.3. If a client holds callbacks on both the file and the volume, the server breaks the callback on the file. The client interprets this as an implicit callback break on the volume, and discards its version stamp. Note that if a client holds a volume callback, it will receive a callback break even if the updated file is not in its cache. This is *false sharing*, and if frequent, may indicate that the granularity of cache coherence is too large for that volume. The client should not blindly reestablish the callback when it is broken, because updates exhibit temporal locality [39, 95]. Not only would this waste bandwidth, but it would also harm scalability. The client's policy should take this into account when determining whether the volume callback should be reestablished.

Note that it is not sufficient to merely send the file identifier in the volume callback break message and allow the client to re-establish the VCB after discarding the file (if cached), because other objects in the volume may change between the time the volume callback is broken and the time the client attempts to reestablish it. Alternatively, the server could continue to notify the client of updates. However, this approach suffers from the same deficiency as blindly reestablishing callbacks because of the temporal locality of updates.

The presence of both volume and file callbacks means clients must decide what kind of callback to obtain when one is broken. Suppose a client validates a version stamp for a volume,

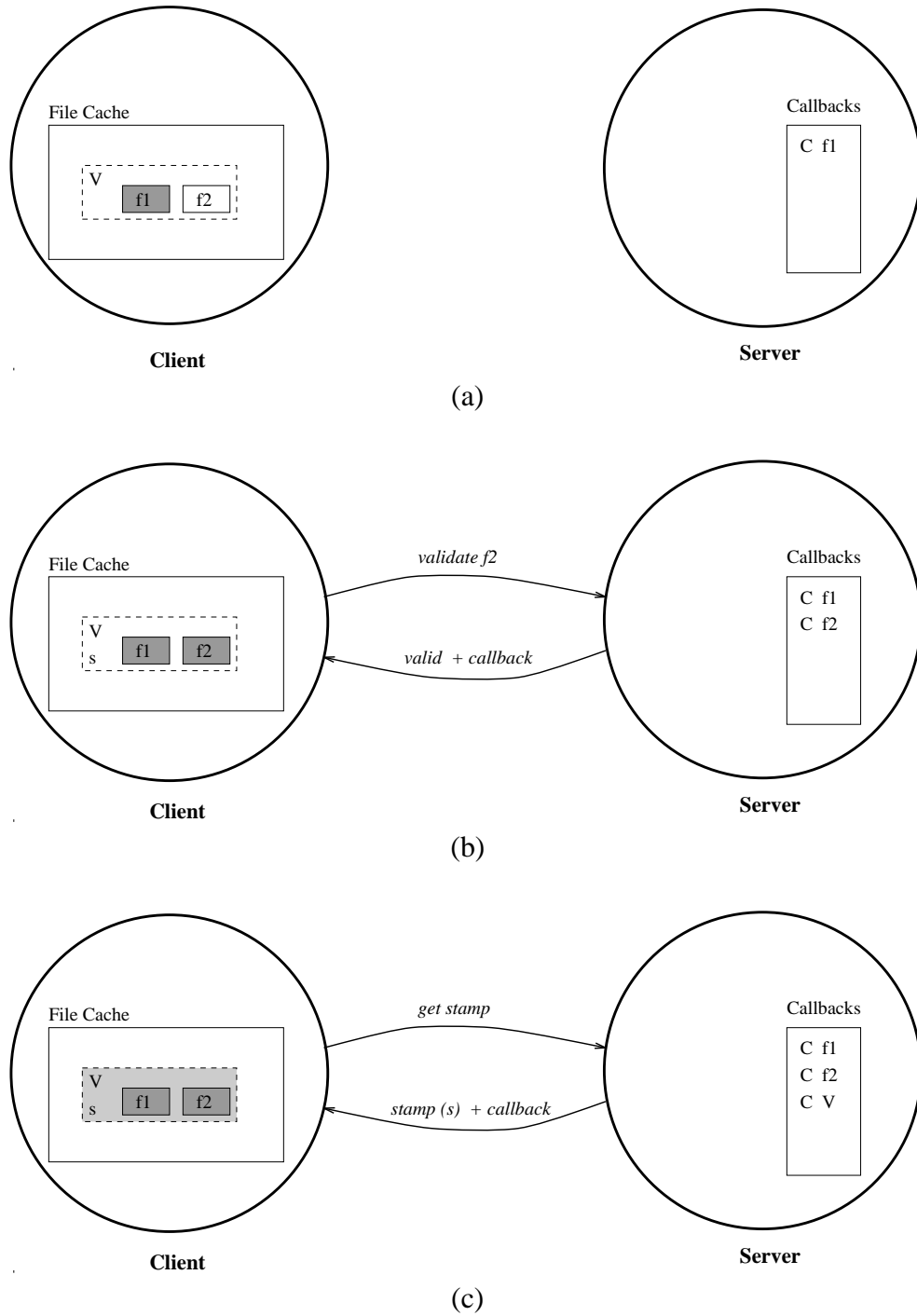

Figure 4.1: Obtaining a Volume Callback

This figure illustrates how a client obtains a volume callback. In (a) the client has cached files f_1 and f_2 belonging to volume V . The client holds a callback on f_1 , as shown by the shading. In (b) the client validates the remaining cached file from V , obtaining a callback on f_2 . At this point the client may request a version stamp for V , as shown in (c).

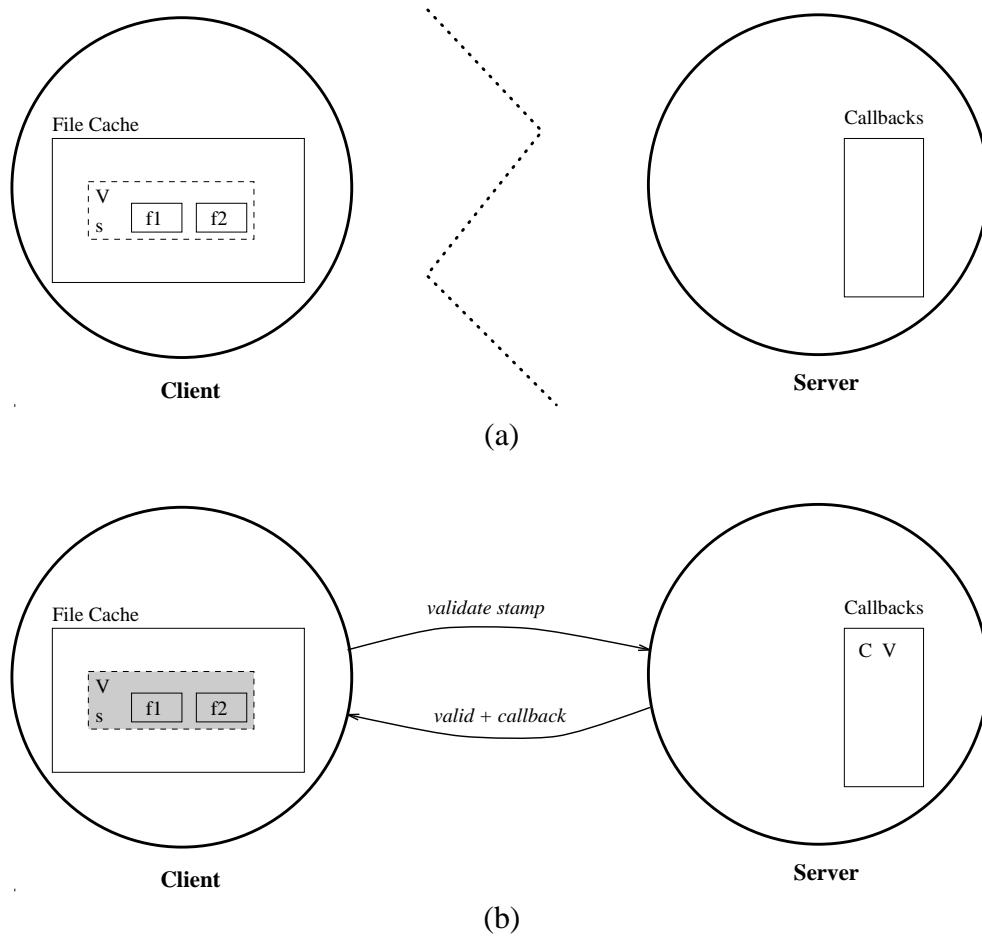

Figure 4.2: Validating by Volume

This figure illustrates volume validation. In (a) the client and server have both detected the partition separating them. In (b) the failure has been repaired, and the client presents its stamp for volume **V**. It is granted a callback, recorded at the server, and may read **f1** and **f2** without additional communication. Note that the server does not know which files from **V** the client has cached.

and it receives a volume callback. At this point it has no file callbacks. If the volume callback is broken, the client must validate its cached files from that volume before it can reestablish the volume callback. In terms of network usage, this is equivalent to recovery from a failure without volume callbacks. In effect, the client has delayed validation of individual files.

In the situation above one might imagine obtaining file callbacks in the background in case the volume callback is broken. This eager strategy assumes a remote update will occur before the next failure. However, this defeats the purpose of obtaining a volume callback. Instead, we employ a lazy strategy, obtaining file callbacks only if the volume callback is actually broken. If no remote updates occur between failures, we have saved the network bandwidth and server memory that would have been required to validate and obtain file callbacks.

4.3 Implementation Details

The implementation of large granularity cache coherence was layered on the existing coherence mechanism. Code changes were required in the Vice interface, the server, and Venus. We discuss these changes in the following subsections.

Server code was required to support the new Vice RPCs, and volume callbacks themselves. Approximately 400 lines of code were added to the server, which consists of approximately 14,500 lines of code excluding headers and libraries. Most of the changes involved supporting the new RPCs (200 lines) and debugging and printing statistics (150 lines). The remainder of the changes were for gathering statistics.

Most of the logic for supporting volume callbacks is contained within Venus. In addition to using the new RPCs, Venus must cope with replication, and decide when using volume callbacks is appropriate. The changes represented an addition of 700 lines to about 36,000 lines of code excluding headers and libraries.

4.3.1 Server Modifications

Volume version stamps were already present as part of *volume version vectors*, maintained at the servers. Like a file version vector, a volume version vector is a summary of the update history for the volume as a whole. The i th slot of a volume version vector on server i in a VSG is the version stamp for the volume.

To minimize changes to code and data structures, volumes callbacks are represented by the unused fid ($\langle \text{VolumeId} \rangle . 0 . 0$). The callback break routine breaks callbacks not only for a file, but also for the volume that contains it.

There are two RPCs in Vice interface that manipulate volume version stamps, shown in Figure 4.4. The first call is `ViceGetVolVS`, which takes a volume identifier, and returns

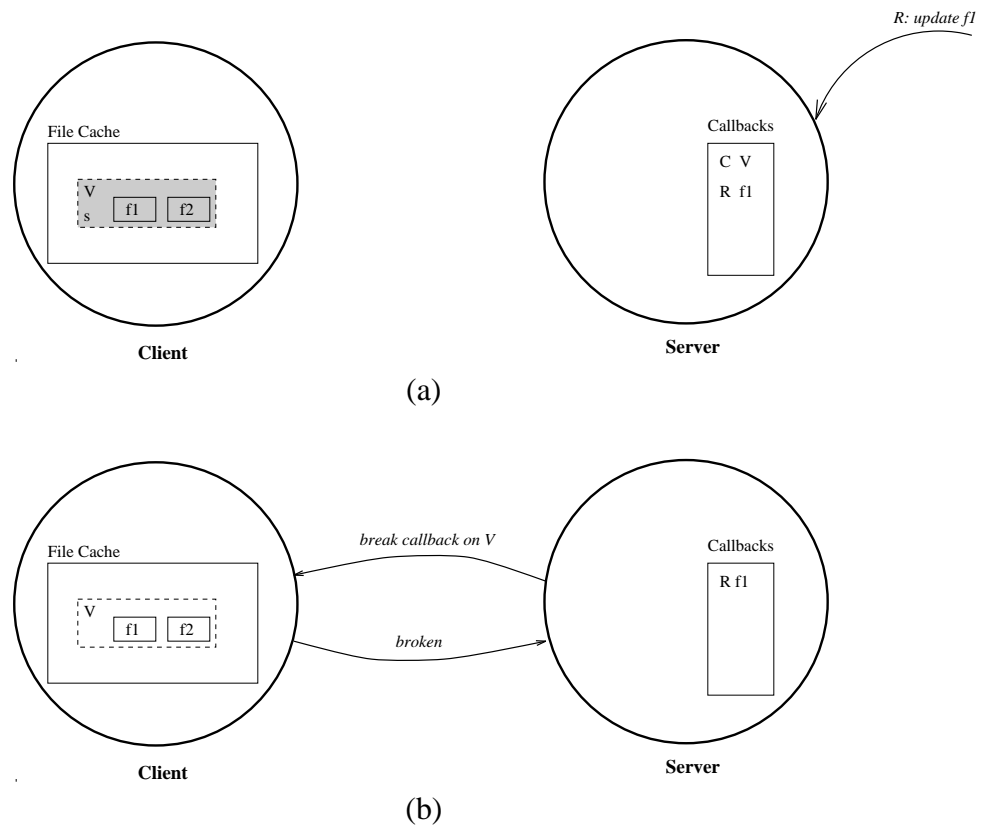

Figure 4.3: Breaking a Volume Callback

This figure illustrates how a server breaks a volume callback. In (a) remote client **R** holding a callback on **f1** updates the file. The server breaks the callback on (b) for the client holding a callback on volume **V**.

```

ViceGetVolVS(IN VolumeId Vid,
             OUT RPC2_Integer VS,
             OUT CallBackStatus CBStatus);

ViceValidateVols(IN ViceVolumeIdStruct Vids[],
                IN RPC2_CountedBS VS,
                OUT RPC2_CountedBS VFlagBS);

```

Figure 4.4: Interface for Volume Version Stamps

This figure shows the Vice RPCs for manipulating volume version stamps. The `ViceGetVolVS` call returns a volume version stamp and optionally a volume callback. The `ViceValidateVols` validates volume version stamps, and sets a volume callback on those that are valid.

a version stamp and a flag indicating whether or not a callback has been established for the volume. The second call, `ViceValidateVols`, takes a list of volume identifiers and version stamps and returns a code for each stamp indicating if it is valid, and if so, whether a callback has been established for the volume. The structure `RPC2_CountedBS` consists of a length field and a sequence of bytes. In addition to these calls, there are new parameters to existing Vice update calls (`mkdir`, `rename`, etc.). These parameters are discussed in Section 4.3.5.

4.3.2 VCB Acquisition Policy

As mentioned in Section 4.2, Venus should have a policy to determine when to obtain a volume callback. The optimal policy would obtain a volume callback only if a failure was going to occur and be repaired before the next remote update. Otherwise, either the volume callback would be broken, or the next validation would fail.

One could invent a variety of policies to approximate the optimal one. Venus uses a simple policy in which it obtains volume callbacks only during hoard walks. This policy is practical for several reasons.

1. The purpose of obtaining a volume version stamp is to prepare for failure. This is synonymous with the purpose of hoarding.
2. A hoard walk validates the cache. Thus the additional overhead of obtaining a version stamp for each volume is low.

3. This strategy maintains scalability. If a volume callback is broken, the client will not request another one until the next hoard walk.
4. Since hoard walks are periodic, the window of vulnerability to failures is bounded. For a client to lose the opportunity to validate files by volume, a remote update would have to be followed by a failure within one hoard walk interval (typically ten minutes). In this case, the client is no worse off than it was before the use of volume callbacks.

This policy also copes nicely with *voluntary* disconnections, when a user deliberately removes a notebook computer from the network. In our environment, many users have both desktop and notebook computers. While at work, they work from the desktop computers, leaving their notebooks connected nearby. Some users modify files hoarded on their notebooks from their desktop. Before disconnecting, they run a hoard walk on the notebook to fetch the files they just changed from the desktop. While connected, the notebook observes the remote updates to volumes that are referenced in its hoard database. These volumes are prime candidates for volume callbacks. This policy takes advantage of explicit hoard walks as hints of imminent disconnection. A policy that becomes more conservative about obtaining volume callbacks when remote updates occur would be unlikely to obtain them in this case.

4.3.3 Access Rights

Directories in Coda have access lists associated with them that specify the operations that a user or group of users may perform. Venus caches access information to perform access checking locally. It does not cache the access lists, because they may be large and specify users or groups unknown to the client. Instead, Venus caches *access rights*, a condensed version of an access list for a particular user. Access rights for an object are returned in the Vice status block, shown in Figure 4.5, which is a result of most Vice calls. The access cache for a directory consists of a fixed number of entries containing a user identifier and that user's rights on the directory. Entries are considered valid when they are installed from the Vice status block. They are considered invalid (or suspect) if the object is invalidated, the user's authentication tokens expire, or if the AVSG grows.

When files are validated in groups, access information is not returned for the individual files. To avoid sending messages to the server to check access information, Venus must use the access cache more aggressively than it did in the past. If a volume is deemed valid, clearly the access rights of a file within it have not changed. Venus now considers entries in the rights cache for a file valid if the file or volume is valid, and the entry corresponds to a user who is authenticated.

```

{
    RPC2_Unsigned      InterfaceVersion;
    ViceDataType       VnodeType;
    RPC2_Integer       LinkCount;
    RPC2_Unsigned      Length;
    FileVersion        DataVersion;
    ViceVersionVector  VV;
    Date_t             Date;
    UserId             Author;
    UserId             Owner;
    CallbackStatus     Callback;
    Rights             MyAccess;
    Rights             AnyAccess;
    RPC2_Unsigned      Mode;
    VnodeId            vparent;
    Unique_t           uparent;
}
ViceStatus;

```

Figure 4.5: Vice Status Block

This figure shows the Vice status block, which is returned for the objects of most Vice calls. It includes version information for the object, whether or not the server has extended a callback promise for it, and the access rights of the requesting user and the anonymous user System:Anyuser.

4.3.4 Effects of Replication

Coda's support of replicated volumes affects the client's handling of volume version state in two ways. First, Venus communicates with the AVSG as a group, sending the same copy of each request to each member of the group. This is performed by the underlying communication protocol, which was designed to support remote procedure call to a set of machines in parallel. Because of this, a validation request must contain the stamps for all the servers in the VSG. Each server simply checks the one corresponding to it.

Second, Venus must collate multiple responses to its requests. When requesting version stamps, it must store the stamp for each server that responds. When validating version stamps, all servers in the AVSG must agree that the stamps are valid before Venus can declare them valid. Similarly, all servers in the AVSG must agree that a callback has been established before Venus can assume it has a callback on the volume.

4.3.5 VCB Maintenance and Updates

When an object is updated, the server increments the version stamps of the object as well as its containing volume. The client receives a status block, shown in Figure 4.5, containing the object's new version information and attributes. Similarly, the client must be able to observe the effects of its updates on the volume version stamp, without receiving callback breaks or sending additional messages.

There are two approaches for updating the client's version stamp when it performs an update – having the client compute the new stamp, or having the server compute and return it. The advantage of having the client compute the new stamp is that no additional changes to the Vice interface are required. Unfortunately, since the server must maintain version stamps anyway, this approach duplicates a good deal of code, and is more difficult to test and maintain.

Instead, the server computes and returns the new version stamp. Each Vice update call has three additional parameters: the old version stamps, the new version stamp, and the callback status. When a client performs an update, it sends its copy of the volume version stamp to the server along with the other parameters for the operation. If the client's stamp is current, the server returns the new stamp and a volume callback. If the client's stamp is stale, the server performs the update but returns a zero stamp and no volume callback. If the client does not have a stamp, or does not wish to obtain a volume callback, it simply sends a zero stamp. This value is guaranteed never to match at the server.

This process is complicated by concurrency control at the server. Objects involved in an update are locked for the duration of the operation. For performance reasons, the server cannot lock a volume for the entire duration of an update. Therefore, it is possible for updates to different objects in a volume to be interleaved. To detect this concurrency, the server updates the client's version stamp along with its own, and checks for a match at the end of the call.

There is a race condition in which the reply containing the callback set for an object is delayed behind a callback break for the same object. This is a general problem and there is a standard technique used to detect the race. Venus records the number of callbacks broken before making an RPC that could return a callback for any object. After the RPC it checks if any callbacks were broken. If so, it conservatively assumes that the broken callback was for an object of the RPC, and it does not set the callback status of any objects of the RPC.

4.4 Correctness

The introduction of multiple granularities rendered the Coda cache coherence protocol sufficiently complex that ensuring correctness became more difficult. This section describes the approach used to ensure that the protocol was correct, and discusses the flaws in the original design revealed by the analysis. Since the analysis itself is lengthy, it appears in Appendix A.

4.4.1 General Approach

The formalism used is a logic based on the logic of authentication developed by Burrows, Abadi and Needham [17, 18] to reason about the correctness of authentication protocols. This logic (henceforth referred to as the “BAN logic”) focused on describing the beliefs of participants in an authentication protocol, and the changes in those beliefs as they communicate. Using this logic, the developers identified errors and inefficiencies in a number of published protocols, one of which had been proposed as an international standard.

The notion of “belief” can also be used to describe cache coherence protocols. Informally stated, the correctness criterion for a cache coherence protocol is: *If a client believes that a cached file is valid then the server that is the authority on that file had better believe that the file is valid.* This insight suggested that the BAN logic could be applied to reason about the behavior of clients and servers in a distributed system, and their beliefs about cached data.

Reasoning about cache coherence is in some ways simpler, but in other ways more difficult, than reasoning about authentication. For example, malicious intent and replay attacks are not at issue because authentication and duplicate suppression are performed by the underlying communication protocol. On the other hand, failures and transmission delays complicate the analysis. These two key characteristics of distributed systems preclude direct use of work in verifying cache coherence for multiprocessors [21, 76].

The strategy for proving correctness consists of first defining the state space and state transitions, then identifying all reachable states, and finally verifying that all possible runs of the protocol maintain cache coherence. For details the interested reader is referred to Appendix A.

4.4.2 Benefits of Formal Analysis

Formal analysis revealed that the initial design of the large granularity protocol was under-specified. Originally there were thought to be ten possible classes of runs of the protocol; the analysis shows that there were fifteen.

Several classes of runs that were missed involved a looping behavior that can occur if a client holds both file and volume callbacks. If the volume callback is broken, the run does not end because the file callback is still present. The file may still be used without contacting the server. Unfortunately, the volume callback may be re-established and broken ad infinitum until the file callback is lost or broken. In practice, this loop is avoidable through the use of a reasonable policy module on the client, which decides when to get a volume callback. While the possibility of this loop was evident in the initial design, its pervasiveness was not. Looping can occur between any states in which a file callback is held, which covers most runs.

The rest of the missed runs involved ordering: if both file and volume state are present at the beginning of the run, they may be validated in either order. It is legitimate for a file to be validated first if conditions do not favor establishing a volume callback upon connection, for example, because of a high rate of remote updates in the volume. Different orders may result in different runs (e.g., if the file is valid but the volume version stamp is not). The implementation was structured such that volumes are always validated first if a volume version stamp is present.

Formal analysis also helped in generating test cases, and early in testing we uncovered a bug in the implementation that harmed the efficiency of the protocol execution, but not the correctness. In the implementation, the client's volume state consists of two fields: the version number, and the callback status. When a volume callback was broken, the client cleared only the callback status field. This is correct, because the client checks the callback status field to determine if there is a callback. However, because the volume version number was still present, the client attempted to validate it with the server on reconnection. The validation was a waste because it was doomed to fail.

4.5 Chapter Summary

For intermittent connectivity to be useful, a system must be able to recover from failures quickly. This chapter described a mechanism that allows file system clients to synchronize their caches rapidly upon reconnection. It does so by introducing an additional level at which cache coherence is maintained, namely the volume. Clients cache and maintain volume version stamps, and present them to servers upon reconnection. If the stamps are current, the client's cached files from that volume are valid, and no additional communication is necessary to access them. Otherwise, the client discards the stamps and reverts to file-based cache coherence. Section 7.4 will show that Coda is able to take advantage of rapid cache validation in the vast majority of cases, and that this mechanism dramatically improves the agility of the system in weakly connected environments.

Chapter 5

Trickle Reintegration

Updates at a weakly connected client are performed locally and logged in stable storage, and then propagated to servers asynchronously. This asynchronous propagation is called *trickle reintegration*. As its name implies, trickle reintegration occurs through a series of *reintegration* operations, which merge the client's updates with server state. In addition to reducing update latency, trickle reintegration alleviates several limitations of disconnected operation. Updates become visible to other clients sooner, allowing sharing and reducing the window of vulnerability to conflicts. The probability of data loss through failure or theft of a mobile client is reduced, because the data is available at servers, and the server copies are both secure and backed up. The challenge of trickle reintegration is to provide these benefits while remaining unobtrusive – the impact of trickle reintegration on foreground activity should be minimal.

This chapter presents a detailed description of trickle reintegration in four parts. The first part compares trickle reintegration to write-back caching. The second part discusses design considerations, and provides an overview of the algorithm. The last two parts discuss design and implementation details, and selection of parameter values.

5.1 Relationship to Write-Back Caching

Trickle reintegration is similar in spirit to write-back caching, as used in distributed file systems such as Sprite [89] and Echo [74]. Both techniques improve update latency by deferring the propagation of updates to servers. They also conserve network bandwidth and server load by taking advantage of updates that cancel or overwrite each other. However, there are several important differences.

First, write-back caching preserves strict Unix write-sharing semantics, since it is typically intended for use in strongly-connected environments. In contrast, optimistic replication allows

trickle reintegration to trade off consistency for performance. In this way, it avoids forcing strongly connected clients to wait for updates to propagate from weakly connected clients.

Second, the primary focus of write-back caching is to reduce file system latency. Reduction of network traffic volume is only an incidental concern. But in weakly connected environments, network bandwidth is precious. Hence reduction of traffic volume is a dominant concern of trickle reintegration.

Third, write-back caching schemes maintain their caches in volatile memory. They suffer from the possibility of data loss due to inopportune failures such as software crashes or the power cycle of the client (an all too frequent occurrence for users of mobile computers). Their need to bound the damage due to failures typically limits the maximum delay before update propagation to some tens of seconds or a few minutes. In contrast, the local persistence of updates is assured on Coda clients. Trickle reintegration can therefore defer update propagation for many minutes or even hours, bounded only by concerns of theft, loss or disk damage.

5.2 Architecture

The goal of trickle reintegration is threefold. First, it should propagate updates with reasonable promptness, for the reasons cited at the beginning of this chapter. Propagation is constrained by the presence and strength of a network connection, and by other activity on the client. These constraints imply that propagation may be delayed indefinitely. To guard against data loss caused by failures, such as software crashes or battery outages, Venus logs updates in stable storage as in disconnected operation. Once an update is logged, it may be propagated to servers in a best effort manner.

Second, trickle reintegration should be unobtrusive. Propagating updates over a weak connection can be a lengthy process. Therefore, trickle reintegration, unlike reintegration, is not a transient event; it is an ongoing concern. Foreground activity, in particular, read and update requests, must not be blocked during reintegration.

Finally, Venus should conserve bandwidth by minimizing the amount of data it sends to the servers. Trace-driven simulations of Coda indicated that CML optimizations, described in Section 2.2.2.2, were the key to reducing the volume of reintegration data [115], and measurements of Coda in actual use confirm this prediction [91]. Reducing the amount of data reintegrated has other benefits such as reducing server load and reducing interference with foreground activity, and it is particularly important if there is non-zero cost associated with the network. For a weakly connected client to take advantage of log optimizations, it must delay update propagation. This goal must be balanced with the earlier goal of propagating updates promptly.

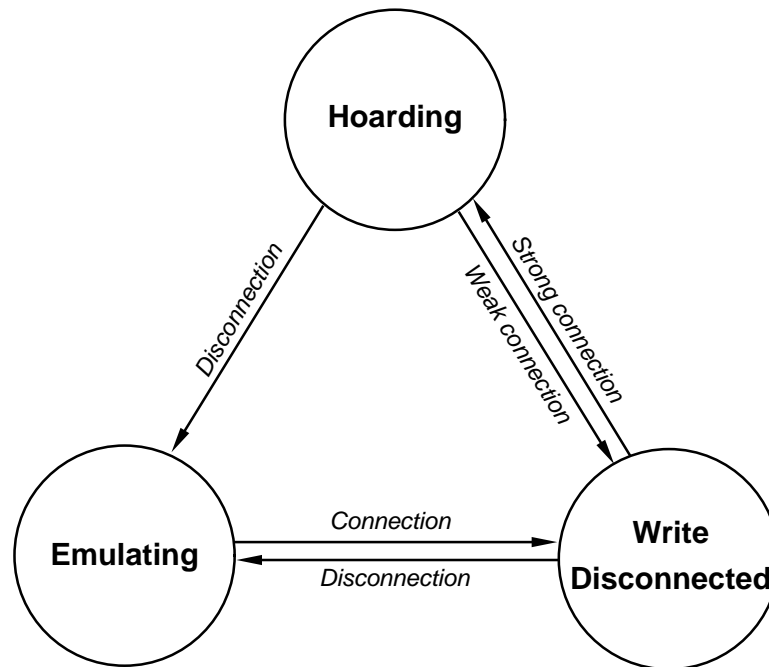

Figure 5.1: Venus State Transition Diagram

This figure shows Venus volume states and the main transitions between them. To support weak connectivity, the reintegrating state of Figure 2.1 is replaced with the “write-disconnected” state. In the write-disconnected state, updates are logged but cache misses may be serviced. Reintegration is permitted only in this state. A transition from emulating to write-disconnected occurs if the CML is non-empty upon reconnection, or if the connection is weak.

The remainder of this section provides an overview of trickle reintegration. First it discusses the structural modifications necessary to make trickle reintegration unobtrusive. Then it describes how Venus decides when to propagate updates, and how it preserves the effectiveness of log optimizations. Finally, it presents an overview of the algorithm in the common case. This description is necessarily oversimplified; implementation details are deferred to Section 5.3.

5.2.1 Structural Modifications

Supporting trickle reintegration required major modifications to the structure of Venus. Because reintegration over a weak connection can be an ongoing process, the original transient reintegrating state of Figure 2.1 has been replaced by a stable *write disconnected* state. Figure 5.1

shows the volume states of Venus and the main transitions between them.

As in the original state model, Venus is in the hoarding state when strongly connected, and in the emulating state when disconnected. When weakly connected, Venus is in the write disconnected state. Venus's behavior in this state is a blend of connected and disconnected modes. As in connected mode, Venus services cache misses (although some misses may require user intervention), and maintains cache coherence using callbacks. As in disconnected mode, Venus performs updates locally and logs them in the CML, and then propagates them to servers asynchronously using trickle reintegration.

Since connectivity is a per-volume property, it is possible for a client to be in different states with respect to different volumes at a given moment. For example, a mobile client may be weakly connected with respect to most volumes, but may be disconnected with respect to a few because their server is down.

A user can force a full reintegration at any time that she is in the write disconnected state. This might be valuable, for example, if she wishes to terminate a long distance phone call or realizes that she is about to move out of range of wireless communication. It is also valuable if she wishes to ensure that recent updates have been propagated to a server before notifying a collaborator via telephone, e-mail, or other out-of-band mechanism.

To avoid penalizing strongly-connected clients, a weakly-connected client cannot prevent them from reading or updating objects awaiting reintegration. Read requests by strongly connected clients are satisfied with data present at the server, because there is no guarantee that the weakly connected updates will propagate in a timely manner (e.g., the weakly connected client may become disconnected) or at all (e.g., the updates may fail when performed at the server). Updates by strongly connected clients result in callback breaks at the weakly connected client. A callback break does not necessarily mean there is a write-write conflict that would prevent reintegration from succeeding; for example, the clients may have added different names to the same directory. Therefore, the client ignores the callback and proceeds as usual. If there is a conflict, it is detected at reintegration time, and may be resolvable automatically (e.g., with an application-specific resolver). Failing that, Venus makes the conflict visible to the user just as if it had occurred after a disconnected session. The user may then apply the existing Coda mechanisms for resolving conflicts [66].

5.2.2 Preserving the Effectiveness of Log Optimizations

Trickle reintegration reduces the effectiveness of optimizations over the CML because records are propagated to the server earlier than when disconnected. Thus they have less opportunity to be eliminated at the client. A good design must balance two factors. On the one hand, records should spend enough time in the CML for optimizations to be effective. On the other hand, updates should be propagated to servers with reasonable promptness. At very low bandwidths,

the first concern is dominant since reduction of data volume is paramount. As bandwidth increases, the concerns become comparable in importance. When strongly connected, prompt propagation is the dominant concern.

How can a client maximize log optimizations? The optimal strategy is to reintegrate only those log records that will not be cancelled. The strategy used to approximate this ideal should have the following properties. First, it should avoid reintegrating “hot spots” in the log. Intuitively, hot spots are updates in the log that are cancelled quickly. If updates are good candidates for optimization, Venus should not attempt to reintegrate them; it should allow time for optimizations to occur. Second, it should allow “cool” prefixes of the log to propagate to the servers. Since the CML is maintained in temporal order, the oldest records are at the head. To ensure that updates arrive at the server with reasonable promptness, the head of the log should not be blocked indefinitely when opportunities for reintegration arise. Intuitively, if an update resides in the CML “long enough”, it is probably worth reintegrating. Last, determining whether to reintegrate a record should be efficient.

Coda uses a simple strategy based on *aging*. The age of a CML record is the length of time it has spent in the log. A record is not eligible for reintegration until it has spent a minimal amount of time in the CML. This amount of time is called the *aging window*, A . Aging avoids hot spots if the aging window is large enough. Cancellations remove older records, with newer records, if any, appended to the tail of the log. Aging also allows inactive log prefixes to propagate to the servers, even if other objects in the volume are active. Calculation of the age is very simple and efficient; each CML record contains its creation time.

The aging window establishes a limit on the effectiveness of log optimizations. The current implementation uses a fixed A , the selection of which is described in Section 5.4. It would be a simple extension to Coda to make the aging window adaptive to connection strength. At low bandwidths, a large aging window allows Venus to minimize data volume by taking advantage of log optimizations. As bandwidth increases, the benefits of propagating updates to the server outweigh the benefits of reducing the amount reintegrated. When strongly connected, there is no need to reduce data volume, and updates are propagated synchronously.

5.2.3 Overview of the Algorithm

Trickle reintegration is performed on volumes in the write-disconnected state. It proceeds in the three stages described for reintegration in Section 2.2.2.3: the prelude, interlude, and postlude. The prelude refers to the preparations Venus makes for sending a reintegration request to the server. The interlude refers to server processing of the reintegration request. The postlude is the client processing of server results and clean-up activities, including commit or abort of the CML records involved. Some of the steps enumerated below were discussed previously in Section 2.2.2.3; such steps are reviewed only briefly.

5.2.3.1 Prelude

Venus begins the prelude for a volume by checking if it is eligible for reintegration. This check may be triggered by a thread referencing an object in the volume, such as a worker LWP or the hoard daemon, or the *volume daemon*, which runs every five seconds. The triggering thread performs the following checks to determine the volume's eligibility:

- volume state check – the volume must be write disconnected. By definition, this means the AVSG is non-empty.
- CML check – the volume's CML must be non-empty.
- authentication check – the volume must have authentication tokens for the CML owner. The server requires tokens to perform updates. If tokens are not present, Venus notifies the user that a reintegration is awaiting tokens.
- reintegration check – the volume must not already be undergoing reintegration.

If the volume meets these conditions, the triggering thread scans the CML to determine if there are records exceeding the aging window. If it finds ripe records, it dispatches a reintegrator thread to do the actual work, and then moves on to its next task. If any of the checks fail, the triggering thread exits the prelude and moves on to its next task.

The reintegrator performs the rest of the reintegration. It begins by completing the prelude, the remainder of which consists of the following steps:

- **prevent interference.** Venus allows most read and update activity in the volume to proceed during trickle reintegration. However, there are several tasks which may interfere with reintegration, or which require exclusive control of the volume to execute. These tasks are blocked until trickle reintegration completes:
 - application-specific resolvers (ASRs), which require control over when their updates are propagated. ASRs use the write-disconnected state and update logging in place of transactional support. Blocking them prevents the reintegrator from reintegrating their updates inappropriately.
 - the *checkpoint daemon*, which periodically writes a backup of the CML and associated data to local disk. Blocking this daemon is necessary because the reintegrator may modify the CML.
 - resolution, which requires exclusive control of the volume.
- **cancel store records for files open for write.** If the file has been modified, the data in the container file may no longer match the description in the store record.

- **determine which records to reintegrate.** The reintegrator scans the log for records that exceed the aging window. Since the CML is maintained in temporal order, the aging window partitions log records into two groups: a prefix containing records older than *A* and a suffix containing records younger than *A*. If the client is weakly connected, the reintegrator selects a subset of the prefix, the size of which depends on the size of the records and data involved and the bandwidth of the network. The selection of this subset will be discussed in Section 5.3.2. The reintegrator then erects a logical divider called the *reintegration barrier* in the CML as shown in Figure 5.2. During reintegration, which may take a substantial amount of time on a slow network, the portion of the CML to the left of the reintegration barrier is frozen. Only records to the right are examined for optimization.
- **replace temporary fids.** While write-disconnected, Venus may run out of permanent fids for newly created objects. If so, it assigns temporary fids to those objects, rather than incur the delay of an RPC to the server to obtain permanent fids during the servicing of a request. If any of the selected records contain temporary fids, Venus now obtains permanent fids from the server via a `ViceAllocFid` RPC, and replaces the temporary ones.
- **lock objects of store records.** Because Venus may service updates during reintegration, the reintegrator must lock the objects associated with `store` records to ensure their data is consistent for backfetching. Locking is described in more detail in Section 5.3.1.
- **pack log records.** The reintegrator allocates an in-memory buffer and marshals the log records into it.
- **select the servers for reintegration.** If the client is weakly-connected, the reintegrator chooses a single server with which to reintegrate. Otherwise, it reintegrates with all AVSG members. This selection is discussed in more detail in Section 5.3.5.

The reintegrator completes the prelude by sending a `ViceReintegrate` RPC to the server. The RPC interface is shown in Figure 5.3.

5.2.3.2 Interlude

The interlude is the processing of the `ViceReintegrate` RPC at the server. The RPC2 socket listener receives the request and dispatches a Vice worker LWP to process it. The processing consists of the following main steps:

- **retrieve the CML.** The CML does not arrive as an argument of the RPC request; rather, the Vice worker transfers it in bulk through an RPC2 side-effect into an in-memory buffer.

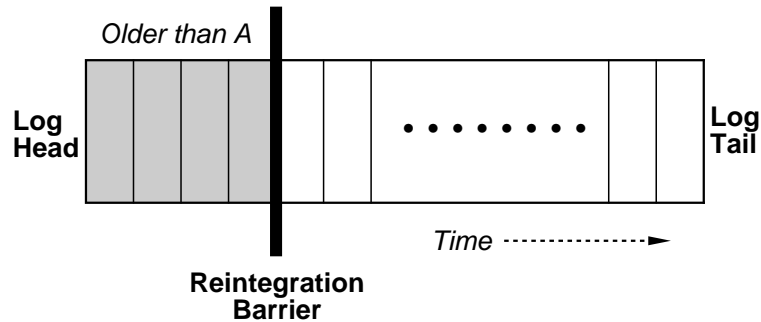

Figure 5.2: CML During Trickle Reintegration

This figure shows a typical CML state while weakly connected. A is the aging window. Venus is reintegrating the shaded records, which are protected from update activity by the reintegration barrier.

```
ViceReintegrate(IN VolumeId Vid,
               IN RPC2_Integer LogSize,
               OUT RPC2_Integer Index,
               OUT ViceFid StaleDirs[],
               IN RPC2_CountedBS OldVS,
               OUT RPC2_Integer NewVS,
               OUT CallbackStatus VCBStatus,
               IN RPC2_CountedBS PiggyCOP2,
               IN OUT SE_Descriptor BD);
```

Figure 5.3: Reintegration RPC

This figure shows the reintegration RPC interface. The `Vid` parameter identifies the volume for which reintegration is requested. The CML length is given in `LogSize`. If a failure occurs, the `Index` parameter identifies the position of the failed record in the log. If any of the directories in the CML are stale, the server returns their identifiers in `StaleDirs[]`. The parameters `OldVS`, `NewVS`, and `VCBStatus` have to do with volume callback maintenance, and the `PiggyCOP2` parameter is used by the update protocol.

- **unmarshall CML records.** The worker unpacks the CML records from the buffer into a sequence of log records.
- **lock objects.** The worker scans the CML to obtain the fids of all of the objects involved, then looks up and write locks the vnodes corresponding to those fids. Deadlock with other workers is avoided by locking vnodes in fid order.
- **check semantics.** The worker performs the semantic checks described in Section B.2.1.2: concurrency control, integrity checks, and protection checks. The concurrency control check for reintegration is certification, as described in Section 2.2.2.3.
- **perform operation.** If the semantic checks succeed, the worker performs the updates tentatively and breaks callbacks to connected clients.
- **backfetch data.** The worker retrieves new data associated with `store` records by making RPCs over the server-to-client callback connection, using the `CallBackFetch` RPC. Venus dispatches a callback handler thread to services these requests.
- **put objects.** If all is well, the worker atomically commits the changes to recoverable storage. Otherwise, it discards the changes. In either case, it releases the vnodes. An error in performing any part of the interlude, for any record, is sufficient cause for the server to reject the entire reintegration.

Finally, the worker sends the RPC reply to the client.

At the client, Venus services user read and update requests for objects in the volume during the interlude, including those being reintegrated. For updates, Venus performs them locally and appends records to the CML as usual. An update request may contend with an ongoing reintegration in two ways. First, a newly appended record may enable optimization of other CML records. If the records eligible for cancellation are not beyond the reintegration barrier, Venus performs the optimization. Otherwise, if they are frozen, Venus marks them “pending cancellation”. Second, the update may involve an object whose data is to be backfetched. This is called *file contention*, because the update and reintegration both require the object’s cache container file. File contention is discussed in more detail in Section 5.3.1.2.

5.2.3.3 Postlude

The postlude begins when RPC2 awakens the reintegrator with either the reply from the server, or an error. The reintegrator performs the following steps to complete the postlude:

- **unlock objects of `store` records.** The reintegrator releases the locks on the objects that it obtained during the prelude.

- **process result.** If reintegration succeeded, the reintegrator atomically commits the records in the prefix. Commitment includes updating object state such as version vectors and data versions, and clearing the dirty bit for objects that are no longer represented in the CML. The reintegrator then removes the reintegration barrier and all the records to its left. If the server indicated that any of the directories involved in the reintegration are stale (the `StaleDirs` out-parameter), the reintegrator invalidates them. The need for this parameter is discussed in Section 5.3.3. Finally, the reintegrator clears any pending CML cancellations, as the records on which they depend have been committed at the AVSG.

If reintegration failed, the reintegrator's actions depend on the type of failure that occurred.

- *semantic failure* – this is a failure in which the server rejects an update, for example, because of a write-write conflict. If the server cannot replay an update, it returns the index of the offending record. Since there is a reply from each AVSG member, the reintegrator identifies the offender with the smallest index. It then *checkpoints* the CML state to local disk, removes the reintegration barrier, and performs any pending optimizations. If the offending record remains, the reintegrator marks the objects involved in conflict. Note that once an object is marked in conflict, the subtree beneath it is inaccessible until the conflict is repaired. The local state is available through repair tools. CML records associated with this local state remain in the log, but they are tagged to prevent their inclusion in future reintegration attempts.
 - *retryable failure* – this is a failure in which the server's response suggests that the reintegration may succeed if tried again later. For example, the server may be temporarily busy. The reintegrator cancels records marked pending as in semantic failures, waits a predefined period of time, and then retries the reintegration. There is a fixed number of retries permissible, after which the failure is treated as a semantic failure.
 - *timeout failure* – this is a failure in which no response was received from the server. Venus cannot make any assumptions about whether or not the reintegration succeeded at the server, so it leaves the log state as is until it contacts the server. This issue is discussed in Section 5.3.4.
- **invoke resolution.** If Venus reintegrated with a subset of the AVSG, the reintegrator invokes resolution on the reintegrated objects to propagate the updates to the remainder of the AVSG. This issue is discussed further in Section 5.3.5.
 - **resume waiting threads.** Any threads blocked by reintegration are resumed at this point.

Reintegration completes with the retirement of the reintegrator thread.

Lock set	Lock to be set	
	Read	Write
None	ok	ok
Read	ok	wait
Write	wait	wait

Table 5.4: Compatibility Matrix for Object Locks

Locking of file system objects follows a single writer/many readers model.

5.3 Detailed Design

5.3.1 Concurrency Control

The original implementation of reintegration used volume-level synchronization, with the reintegrator thread obtaining exclusive control of the volume for the duration of the operation. Other requests for data in the volume, cached or not, were blocked until reintegration completed. The advantage of this scheme is simplicity – there is no need to lock individual objects because no other thread is allowed to execute requests in the volume. Deadlock is not an issue, for the same reason. The implicit assumption of this approach is that reintegration latency is low. If this assumption holds, the lack of concurrency within the volume is not a serious disadvantage. However, this assumption does not hold in weakly connected environments. On a weak connection, reintegration latency arises from two sources: transmission of the log, and transmission of new file data. The former can be controlled by making the amount of the CML being reintegrated arbitrarily small. The latter cannot be controlled because a single `store` record could involve storing a large file.

It is desirable to allow concurrent activity within a volume during a potentially long-lived reintegration. Specifically, Venus should be able to service read requests to objects in the volume, whether or not they are participating in the reintegration. A read of a reintegrating object is no different from a read of the object while disconnected. Venus should also service update requests to objects in the volume. Exclusive volume locking precludes both of these activities. The remainder of this section describes how reintegration retains a reasonably simple, deadlock-free implementation, while allowing more concurrency within the volume.

5.3.1.1 Object-Level Concurrency Control

Venus services reads and updates to objects in a volume undergoing trickle reintegration by using object-level concurrency control. The reintegrator locks objects in the prelude and the postlude. In the prelude, it read-locks the objects of `store` records. Locking is necessary to ensure that the version of the data backfetched by the server is consistent with the `store` record. Read-locking prevents the objects from being updated or removed, as shown in the object lock compatibility matrix in Figure 5.4.

In the postlude, if reintegration suffers a semantic failure, the reintegrator must abort the offending records and quarantine the objects that were involved. The reintegrator must write-lock objects for abort to ensure that no other threads are reading or updating them. The reintegrator does not lock objects during commit, even though the object's version vectors are updated, because it is the only reader and writer of these fields until the objects are cleaned.

During reintegration, Venus services read requests as usual, relying on cached state if available (even if it is reintegrating), or fetching objects from servers if necessary. Venus performs update requests locally and logs them in the CML. An update may require write access to a file whose data is being backfetched (i.e., the file is read-locked). This phenomenon is called *file contention*, and is described below.

5.3.1.2 File Contention

Both volume and object-level concurrency control suffer from blocked updates to varying degrees. Object-level locking blocks repeated updates to the same file. Unfortunately, locality of reference suggests that even this case will happen frequently. (Indeed, this is why log optimizations are so effective.) File contention usually indicates the aging window is too small, and it is most severe at the lowest bandwidths. To avoid holding resources while waiting for the network, Venus creates a shadow copy of the cache container file associated with an `fsoobj` when it detects contention. Shadowing thus involves no overhead in the absence of contention. As shown in Figure 5.5, the shadow includes a copy of the `CacheFile` structure used to describe the container file. This structure consists of the container file name, its inode number, and its length.

When a thread tries to write lock an `fsoobj`, Venus determines if the object is already locked for backfetch. If so, the container file associated with the `fsoobj` is moved to the shadow copy, and a new `CacheFile` structure is allocated to describe the shadow. The data from the shadow container file is then copied back to the main container file. The container file is moved to the shadow rather than copied to preserve any backfetches already in progress, and to ensure that they complete out of the shadow. If the backfetch has not yet begun, the backfetch code opens and fetches from the shadow if one exists. Once the shadow is constructed, the object is unlocked, and the thread blocked on the write lock obtains the lock and proceeds.

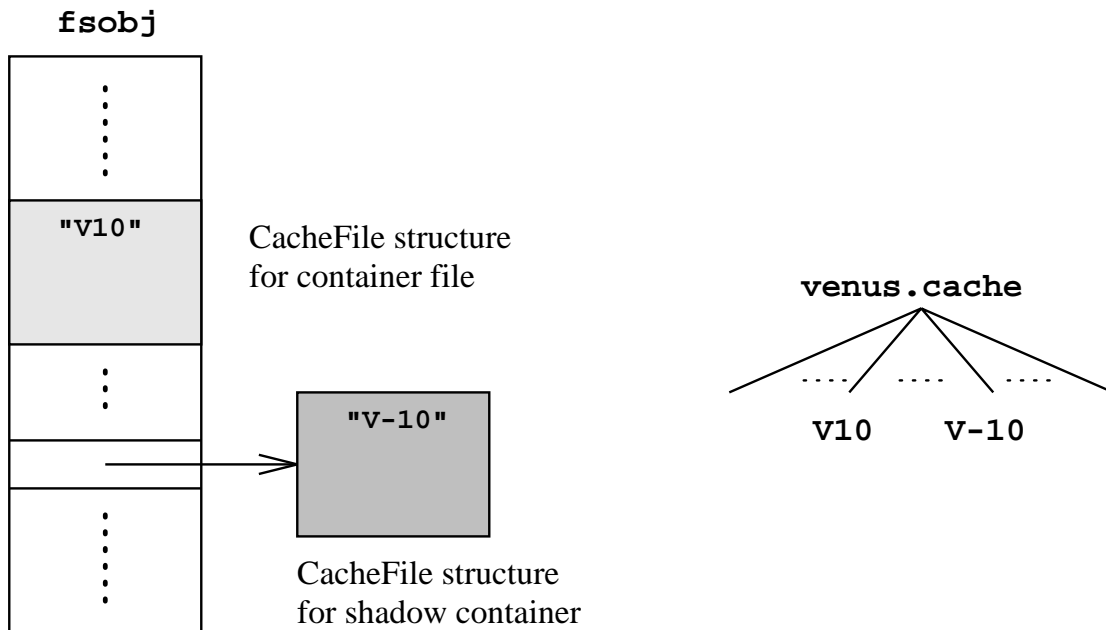

Figure 5.5: Shadowing Cache Files

This figure shows an `fsobj` with a shadow cache file. The shadow is created during reintegration if an update occurs to a file while Venus is reintegrating a `store` record for that file. The `fsobj` includes a `CacheFile` structure describing cache container file `v10`. A new `CacheFile` structure is allocated to describe shadow container `v-10`. When reintegration completes, Venus removes the shadow container and associated `CacheFile` structure.

Any updates it performs are added to the CML. When reintegration completes, the reintegrator thread removes the shadow. Because reintegration does not survive crashes or shutdowns, there is no need for the shadow file to be recoverable. At startup, Venus removes any shadow cache files left over from its previous incarnation.

The amount of space consumed by shadow files is a concern for a resource-poor mobile. Only the objects of `store` records, namely files, may have shadow copies. Because only one reintegration is permitted in a volume at a time, a file may have at most one shadow.

5.3.1.3 Deadlock Prevention

It is important to ensure that the reintegrator's use of object locks is deadlock-free. The necessary conditions for deadlock are [96]:

1. Mutual exclusion – at least one resource must be held in a non-sharable mode.
2. Hold and wait – there must exist a thread that is holding at least one resource and waiting to acquire others.
3. No preemption – once a thread holds a resource, only it may release the resource.
4. Circular wait – the deadlock itself is a set of processes holding resources in a pattern that forms a cycle in the wait-for graph.

In Venus, locks are non-preemptive, and write locks are non-sharable. To prevent deadlocks, either the “hold and wait” or the “circular wait” conditions must be prevented.¹

During the prelude, the reintegrator read-locks the objects of `store` records. These objects are files (i.e., leaf nodes in the file system hierarchy). For a deadlock involving the reintegrator to occur, there must be another thread that locks more than one leaf node (hold and wait), uses write locks (mutual exclusion), and locks in no particular order (allows circular wait). There is only one operation other than reintegration that write locks more than one leaf node – `rename`. Requiring both `rename` and reintegration to lock leaf nodes in `fid` order removes the circular wait, thereby preventing deadlock.

During the postlude of an aborted reintegration, the reintegrator write-locks all objects involved. Unfortunately, these objects are not necessarily leaf nodes. Objects are aborted in order of their occurrence in the CML, which is not necessarily in `fid` order. Thus there exists the potential for deadlock during CML abort. To prevent deadlock, Venus removes the “hold and wait” condition by having the reintegrator thread first release its locks on the backfetched objects before abort, and then reacquire them as it aborts each record.² If a record involves more than one object, the reintegrator locks, aborts, and unlocks each object one at a time. Because it does not hold and wait, it cannot be part of a deadlock.

¹The original implementation's use of an exclusive volume lock prevents deadlocks by removing the “hold and wait” condition, because the volume lock is the only lock that need be held. Despite this, the reintegrator thread still write locks objects during CML abort. If locks were held across requests, the reintegrator thread could deadlock.

²The objects do not vanish, even if subsequent updates delete them, as long as they are represented in the CML. Once the reintegrator releases the lock on an object, it is possible for another thread to service a request involving the object before the reintegrator reacquires the lock. Such a request is doomed, in a sense, because it involves state that is about to be aborted. This example is an instance of a more general problem in which the request arrives any time before the failed reintegration begins.

5.3.2 Reducing the Impact of Reintegration

Given a prefix of the CML older than A , how much of it should Venus reintegrate at once? There is a tradeoff associated with the amount of the log, or *chunk size*, that Venus sends to the server for a single reintegration. A small chunk size maximizes the likelihood of success, because there is less time for failures to strike, and there are fewer records to pass through semantic checks at the server. A small chunk size also minimizes the likelihood that reintegration will interfere with other tasks requiring the network, such as a demand fetch. On the other hand, a large chunk size allows Venus to amortize the fixed costs of reintegration, such as RPC latency and transaction commitment. Clearly, as network bandwidth increases, the effect of chunk size on reintegration latency decreases. The chunk size should therefore be adaptive to network bandwidth.

The goal is to reintegrate the largest amount of data that is likely to succeed, without interfering with other tasks requiring the network. Venus places a time limit on reintegration, and calculates the chunk size C based on this limit and an estimate of the current bandwidth.³ The default time limit is 30 seconds, which corresponds to a C of 36 KB at 9.6 Kb/s, 240 KB at 64 Kb/s, and 7.7 MB at 2 Mb/s. Venus then selects the maximal prefix of the CML that is older than A and whose sizes sum to C or less. This prefix is the chunk for reintegration. The reintegration barrier is placed after it, and reintegration proceeds as described in Section 5.2.3. This procedure is repeated a chunk at a time, deferring between chunks to high priority network use, until all records older than A have been reintegrated.

Because most log records are small, Venus is usually able to find a prefix of the log that fits within the reintegration limit. There is one exception, the `store` record, which is accompanied by new file data. If the amount of data is large, reintegration of the `store` record alone may exceed the reintegration limit. In this case, Venus should be able to make forward progress without monopolizing the link, and in spite of intermittence. Venus transfers the file as a series of *fragments*, each of which fit within C . The state of the transfer is preserved across connections; if a failure occurs, the transfer continues from the last successfully transferred fragment. The atomicity of reintegration is preserved, because the server does not reintegrate the `store` record until all of its data has arrived at the server. Note that this is the reverse of the procedure at strong connectivity, where the server verifies the logical soundness of the updates before fetching file data. The change in order reflects a change in the more likely cause of reintegration failure in the two scenarios; while weakly connected, a failure during file transfer is much more likely than a semantic failure.

This mechanism is simply a form of fragmentation and reassembly. While fragmentation and reassembly services are provided at lower system layers, the duration of reintegration over

³If a measure of the reliability of server connections is maintained, such as a distribution of connection lengths, the time threshold could also be made sensitive to intermittence.

a weak connection is long enough to warrant higher level control. Consistent with the end-to-end argument [107], Venus provides a high-level version of fragmentation and reassembly because only it has the information necessary to determine the appropriate chunk size. Using this mechanism, Venus can recover from failures without resending the entire file, allowing it to make incremental progress in spite of intermittence.

5.3.2.1 Reintegrating Fragments

When Venus transfers a fragment, the data is stored in a *shadow inode* for the file at the server. In this way the partially transferred data is not exposed to requests from other clients, and requests from other clients are not blocked at the server while Venus transfers the new data. Venus references the shadow inode for a file using a *handle*. The handle is a 3-tuple consisting of the server birth time, and the shadow inode's device and inode number. The handle is independent of a specific connection, because the duration of a file transfer over a weak link may exceed the lifetime of a single connection. Indeed, it may even exceed the lifetime of Venus. For this reason, Venus keeps handles in the `store` record, which is persistent.

Because Venus may disconnect for arbitrarily long periods, or may cancel a `store` record before it finishes transferring the data, the server must be able to garbage collect shadow inodes periodically. The *salvager*, a server thread which runs at startup, automatically garbage collects such inodes. To detect if a request involves a shadow inode that has been garbage collected, the server checks the birth time of the handle. This scheme could be generalized for garbage collection at other times by using an epoch number in place of the server birth time.

There are four calls in the Vice interface pertaining to reintegration of files by fragment, shown in Figure 5.6. Venus requests creation of a shadow inode at the server using the `ViceOpenReintHandle` call. The server returns a handle for a shadow inode associated with the specified `fid`. Venus retains the handles returned by the VSG in the `store` CML record, and uses them in the remaining three calls. Venus sends fragments of a file using the `ViceSendReintFragment` call. Venus transfers a fragment by specifying the offset within the file and the number of bytes to be transferred in the SFTP descriptor. Just as in a backfetch, Venus transfers the fragment from a shadow container file if one exists. Should a failure occur, Venus may check the status of a shadow inode using the `ViceQueryReintHandle` call, which validates the handle and returns the current length of the file at the server.⁴ When Venus has transferred all of the data to the server, the `ViceCloseReintHandle` call reintegrates the `store` record using the data in the shadow inode. Except for the absence of a backfetch, the server performs the same reintegration interlude described in Section 2.2.2.3.

If multiple clients attempt to transfer fragments for the same file, the server will create shadow inodes for each client, and the handles it returns will differ by inode number. The host

⁴The query and send calls could be combined, but a separate query mechanism allows for more sophisticated queries and negotiation.

that completes its data transfers and reintegrates first will succeed. Subsequent reintegrations by the other hosts will fail.

5.3.2.2 Selective Reintegration

By default, the CML is reintegrated in temporal order. One possible refinement would allow a user to reintegrate updates pertaining to specific objects. To implement this refinement, Venus must track the dependencies between records, and first reintegrate the antecedents of the updates of interest. For example, updates to `foo.tex` depend on the creation of its parent directory. Dependencies are captured by a *precedence graph* [29] computed for the CML. A precedence graph is a directed graph consisting of nodes representing transactions, and arcs representing dependencies between those transactions. The direction of the arc indicates the order between the transactions. In the context of Coda, the transactions are CML records, and the dependencies refer to write dependencies.⁵ Precedence graph construction is not necessary at present because the temporal ordering of the CML guarantees that antecedents are reintegrated first.

5.3.3 Remote Updates and Volume Callbacks

There is an interaction between volume callbacks, discussed in Chapter 4, and reintegration of updates to directories that have been updated remotely. If an object is dirty, Venus considers it valid whether or not it holds a callback, and services requests for the object from the cache. Venus may obtain a callback on a volume for which it has dirty cached objects, and maintain the volume callback through reintegration. Because directories are certified by value, it is possible for Venus to cache stale directory state through a successful reintegration. Recall from Section 4.1.2 that a volume callback may serve as a substitute for a file (directory) callback. Therefore, to maintain cache coherence, Venus must not retain both the stale directory state and the volume callback.

This interaction does not occur frequently. To trigger it, a client must update a directory while disconnected or weakly connected. Then, before reintegrating, a second client must update the directory at the server, and the first client must obtain a volume callback on the directory's volume. Finally, the first client must reintegrate successfully, and maintain its volume callback.

A good solution to this problem requires computation and message traffic proportional only to the number of stale directories. That number is small, and often zero. Clearly, discarding the volume callback after reintegration is not desirable. Nor is the class of solutions requiring work on every remote update (callback break), because not all remote updates correspond to dirty

⁵The CML does not contain enough information to capture read dependencies, such as in an operation `cat foo > bar`.

```

ViceOpenReintHandle      (IN ViceFid Fid,
                          OUT ViceReintHandle RHandle);

ViceQueryReintHandle     (IN VolumeId Vid,
                          IN ViceReintHandle RHandle[],
                          OUT RPC2_Unsigned Length);

ViceSendReintFragment    (IN VolumeId Vid,
                          IN ViceReintHandle RHandle[],
                          IN RPC2_Unsigned Length,
                          IN OUT SE_Descriptor BD);

ViceCloseReintHandle     (IN VolumeId Vid,
                          IN RPC2_Integer LogSize,
                          IN ViceReintHandle RHandle[],
                          IN RPC2_CountedBS OldVS,
                          OUT RPC2_Integer NewVS,
                          OUT CallbackStatus VCBStatus,
                          IN RPC2_CountedBS PiggyCOP2,
                          IN OUT SE_Descriptor BD);

```

Figure 5.6: Interface for Reintegration by Fragment

This figure shows the interface for reintegration of files by fragment. The `ViceOpenReintHandle` call creates and returns a handle for a shadow inode at the server, and the `ViceSendReintFragment` call deposits file data into the shadow inode. If a failure occurs before the fragment is transferred completely, Venus may check the status of a handle with the `ViceQueryReintHandle` call. Finally, reintegration with file data present at the server is accomplished with `ViceCloseReintHandle`. Arrays of RHandles are specified for the latter three calls because Venus must send each server its handle.

objects, and these solutions would introduce more distributed state into the system which would have to be maintained. Solutions that involve validating dirty directories after reintegration are also not ideal, because it is likely that most of the directories will not be stale.

Since the server performs version checks on each object involved in a reintegration, it is a simple matter for it to indicate which, if any, of the directories involved in the reintegration are stale. The server returns, as a result of the `ViceReintegrate` RPC, a list of fids that correspond to stale directories in the client's cache. Venus marks those directories invalid, and purges them once all references to them are cleared.⁶ If Venus maintains a volume callback through the reintegration, it is assured that no clean directory state will become stale. Even if Venus does not have a volume callback, it is still saved from performing doomed validations of stale objects. The computation and message traffic expended by this solution is minimal, and proportional to the number of stale directories involved in the reintegration.

5.3.4 Ensuring Atomicity

The original implementation of reintegration was flawed with respect to one class of failures, namely, when a reintegration completes at the server successfully but the RPC response to the client is lost in spite of retransmissions. This failure can occur if a network partition separates the client and server during the interlude. When this failure occurs, reintegration succeeds at the server but fails at the client. Venus declares the server down and preserves the log state so that the operation may be retried when the failure is repaired. Unfortunately, the retry is doomed, because the operations have already completed at the server.

This problem is rare on LANs because of their high reliability – even if the RPC response is lost, it is likely that the RPC layer at the client will retry the request and provoke another response. However, in an intermittent environment, this problem occurs frequently enough that it must be addressed. The problem first arose on clients connected via SLIP. Although SLIP connections are slow, one would expect them to be reasonably reliable. However, the SLIP gateway Coda clients used had a bug that caused it to freeze for periods exceeding the system timeout interval, thus producing intermittent behavior.

A standard solution to this sort of problem is to employ a *distributed two-phase commit protocol* [28] in which the client is the coordinator, and the servers are subordinates. Each server indicates whether or not the operation succeeded. The client collects the server responses, and if all is well, it sends a “commit” message to each server. Otherwise, it sends an “abort” message. Each server then commits or aborts the reintegration as instructed, and acknowledges the client. Reintegration completes at the client when it receives acknowledgements from all servers. Note that the server must be prepared to “go either way” with the request from the

⁶There may be other CML records, not yet reintegrated, that also refer to these directories. In the meantime, Venus may continue to service requests on these directories, including updates, from the cached copy.

time it indicates the outcome to the client to the time it receives the final outcome from the client. In particular, all resources needed to complete the reintegration must be held until the outcome is known. If the client crashes during this interval, the server is blocked, holding locks on the objects involved in the reintegration. Because clients may disconnect for arbitrarily long periods, this vulnerability to failures makes distributed two-phase commit unattractive.

Instead, if the client times out, it presumes that the reintegration failed at the server (the more likely outcome), but detects if it succeeded. Servers retain the identity of the last record reintegrated in each volume from each client. The identifier is the *store ID* embedded in each log record. The store ID is a ⟨host ID, uniquifier⟩ pair. The uniquifier is initialized with the system time and incremented on each use. Thus the store ID is strictly increasing over time and unique across client restarts. When the server receives a CML, it compares the store ID of the first record with its last store ID for the client, if any. If its uniquifier is greater than that of the first log record, it returns an error to the client along with its store ID. The client then commits all log records up to and including the one with the matching store ID and retries the operation with the remaining CML.

To ensure atomicity, the server must commit the identifiers to recoverable storage. However, the administrative tasks required to change the format of a server's recoverable storage are considerable. For this reason, the server maintains the identifiers in volatile memory. Hence, it is still possible for reintegration to fail non-atomically if the server crashes after completing reintegration, and the client does not receive a reply. This failure mode is no more frequent than server crashes, and therefore no more frequent than its original occurrence rate in a LAN environment.

After most failures, Venus applies log optimizations over the prefix of the log that was being reintegrated. The advantage of optimizing after failures is two-fold: subsequent reintegrations involve less data, and the offending record may be cancelled. However, care must be taken in applying log optimizations when the client times out, because one cannot be certain that reintegration failed at the server. If reintegration succeeded, the results of records that the client would cancel may be visible to other clients. For example, suppose Venus has a CML containing records `create foo`, `remove foo`, `create foo`, and it times out while attempting to reintegrate the first `create` record. If the reintegration succeeded at the server, `foo` is globally visible. Venus must send the `remove` record to the server, otherwise the subsequent `create` will fail. Therefore Venus applies optimizations over the log prefix for reintegration failures only if it receives a response from the server. If it receives no response, optimizations for records in the log prefix remain disabled until their fate is known.

For a replicated volume, the responses for a subset of the AVSG may be lost. In this case, the Venus times out on the corresponding servers, and reintegrates with the remaining AVSG. If reintegration succeeds, Venus commits the operations in the log prefix and discards those records. If the AVSG then grows, the existing resolution mechanisms are applied to the objects involved in the previous reintegration. If they are successful, the reintegration proceeds. It

is possible for the client to find itself in a situation in which the servers do not agree on the identity of the last reintegrated record. In this case, Venus declares failure and marks the objects associated with the log head in conflict, as it would for a semantic failure.

5.3.5 Effects of Server Replication

When strongly connected, Venus reintegrates with all AVSG members in parallel. Each server receives a copy of the CML, and then backfetches the new file data from the client. This strategy is based on the assumption that clients and servers are connected by a fast network. In such an environment, it is reasonable to expend bandwidth to maximize availability by reintegrating with as many AVSG members as possible. However, when bandwidth is scarce, Venus must minimize the amount of data sent over the weak link, while still maximizing the probability that all AVSG members receive the updates.

5.3.5.1 Backfetching

An obvious way to avoid sending multiple copies of data over the weak link is to use multicast beneath RPC2, as described in Chapter 3. Unfortunately, in addition to the issues discussed in that chapter, the implementation of reintegration is not structured to take advantage of multicast. Although Venus would no longer send multiple copies of the CML, each AVSG member would individually backfetch a copy of the new file data. Servers perform backfetches independently on their server-to-client callback connections; logically these requests are not multicasts. As the data in Section 5.4 shows, the vast majority of data transferred during reintegration occurs during backfetch.

Backfetching over a different connection than the reintegration request introduces another problem for weakly connected clients, namely, that traffic on the different connections can interfere, even though it occurs on behalf of the same request. The connection on which Venus makes the reintegration RPC has no knowledge of progress on the callback channel, and will time out if a response isn't forthcoming. On a weak connection, the retransmissions can contribute to congestion, and may cause the reintegration RPC to time out even though backfetches are proceeding normally.

A solution to both of these problems is to modify RPC2 to allow multiple side effects per RPC, rather than a single one. The reintegration RPC would then include a side effect descriptor for the CML, as it does now, and an additional descriptor for each container file whose contents are to be backfetched. The backfetches would occur in series, over the same connection as the reintegration request. This strategy would have lower RPC overhead than the current one, because only one RPC is performed per reintegration instead of an additional RPC for each backfetch. Backfetch traffic would not interfere with the reintegration request

because RPC2 and its side effects share liveness information, as described in Section 3.2.3. Backfetches would also be amenable to multicasting. The main disadvantage of this scheme is that if a failure occurs, communicating its identity to the application would be awkward.

5.3.5.2 Resolution

Coda uses a solution independent of multicast, relying instead on the resolution subsystem. It assumes that the servers are strongly connected to each other – an assumption required by other parts of Coda. While weakly connected, Venus reintegrates with a single server. If reintegration succeeds, the reintegrator thread then invokes resolution on all reintegrated objects to propagate them to the remaining AVSG members. In principle, Venus could reintegrate with a subset of the AVSG, the size of which is dependent on the strength of the connection.

There are several potential drawbacks to an implementation that depends on resolution. First, resolution is performed lazily, imposing a delay when the object is next referenced. But since the reintegrator triggers resolution in the background, most if not all of the delay is hidden from user requests. Second, servers break callbacks on the objects of resolution, because the resolution protocol updates at least their version vectors.⁷ Although Venus must refetch the status of the objects after resolution, it does not refetch the data unless the object's data actually changed. Suppression of data fetches is described next in Section 5.3.5.3. Last, a guiding principle in the design of Coda is that clients bear the brunt of the work. Resolution is a four-phase protocol that involves all servers in the AVSG; compared to reintegration, resolution is a heavyweight operation. Two factors mitigate the increased server load. First, a weak connection limits the rate at which a client can issue server requests. Second, it is less costly for a server to fetch data from another strongly-connected server via resolution than to backfetch it from a weakly-connected client.

There is a refinement to this solution that would decrease the number of resolutions necessary to propagate updates to all AVSG members. It is a hybrid of the reintegrate-with-all model used by strongly-connected clients, and the reintegrate-with-one-and-resolve model used by weakly-connected clients. In the hybrid approach, Venus would send the CML to all servers, but only one server would backfetch new data. Venus would then invoke resolution only for the objects of `store` records. This solution takes advantage of the fact that most of the data for reintegration is backfetched. It expends a small amount of bandwidth to eliminate resolution and status refetch for directories, and may be useful for intermediate points in the connectivity spectrum. The implementation of this solution would require servers that do not backfetch leave enough state behind to trigger a resolution upon reference from any client, because a failure may prevent the reintegrating client from invoking resolution. This is not an issue

⁷The current implementation of resolution requires servers to update their version vectors whether or not they perform compensating operations. The implementation could be refined in certain cases, such as file resolution, to suppress the callback break from servers that already possess the most recent copy of the object.

in the reintegrate-with-one-and-resolve model, because only one server actually performs the updates.

5.3.5.3 Suppressing Data Fetches

A callback break does not necessarily mean an object is invalid. It simply means that the server no longer promises to tell the client if it becomes invalid. A server may break callbacks arbitrarily, for example, to garbage collect state. The client is free to request another callback.

A server sends callback breaks to clients when it performs an update, regardless of whether the update changed the status of the object or both status and data. Strongly connected clients normally invalidate and discard an object upon receiving a callback break. This could result in unnecessary data fetches if the data was unchanged. While this is not a serious problem for a strongly connected client, a weakly connected client would be squandering knowledge that takes time to obtain. Thus a weakly connected client should not discard data gratuitously; it should retain it until there is strong evidence that the data is actually invalid. This is particularly important in view of the resolution protocol, which updates at least the status of an object on every invocation.

There are several ways to suppress unnecessary data fetches in the implementation. Coda uses the *data version* field of the Vice status block to detect status-only updates. This field is used for concurrency control checks of non-replicated objects at the server, as a version vector is used for replicated objects. It is incremented only during update operations that change the data. When Venus receives a callback break, it retains the data until it obtains a new status block for the object. It then determines the currency of its data by checking a separate data version field. Since data version numbers may differ from server to server, Venus keeps a vector of data versions, similar to the version vector, and checks the appropriate element for each server. Validating an object then proceeds as follows. First Venus compares the version vectors obtained from the server with the cached copy. If the version vectors are equal, the client has the correct data. If the version vector check fails, and the server's version vector is dominant, the updates at the server could have updated only the status, or both status and data. Venus uses the data version to distinguish the two cases. Data versions require maintenance. Venus must increment them after all locally performed updates. While disconnected, it must also decrement them as appropriate when CML records are cancelled.

The main advantage of the client-based solution is that no changes to the server implementation are required. The disadvantage is that an extra status check is necessary after a callback break to determine which part of the object changed.⁸ A cleaner solution, which would require

⁸An old version of AFS had a "Check and Fetch" RPC that worked as follows. A client supplies the status block of the file it has. If the status is valid, the server grants a callback. If the status is not valid, the server sends the new status block, then transfers new data, and then grants a callback. Either way, the client ends with new

more work at the server, would be to associate a type with a callback. The server would then break callbacks on status or status and data as appropriate.

5.4 Selecting an Aging Window

What should the value of A be? The choice of A trades off prompt propagation to servers against reduction of data volume through log optimizations. To choose a good default value for A , one must understand when log optimizations tend to occur, and how effective they are as a function of time.

This section describes a trace-based simulation study to determine a good default aging window. Although Venus uses a fixed A , its value may be changed from the command line using the `cfs` program, or from a program using the `pioctl` interface. The optimal value is of course workload dependent, and this study is based on workloads that are common in academic environments. However, this procedure for selecting a default is applicable to any workload.

5.4.1 File Reference Traces

The simulation study was based on file reference traces collected using the DFSTrace system [86] from workstations in the School of Computer Science at Carnegie Mellon University. Over two years of detailed traces were collected from 1991 to 1993 from approximately 30 workstations and Coda file servers. The traces were recorded at the level of Unix system calls, and capture references to any file system a workstation accesses. In our environment, workstations access the local Unix file system as well as a variety of distributed file systems including AFS, NFS, and Coda. The content of the trace records for each operation is presented in Table 5.7.

The traces used for this study were the same as those chosen by Jay Kistler for his evaluation of client storage requirements for disconnected operation and reintegration latency [62]. These traces consist of two groups of five traces each, collected for the most part from single user workstations. The first group, the *work-day* traces, contained 12-hour periods of user activity. The second group, the *full-week* traces, contained 168-hour periods. A summary of the traces is shown in Table 5.8. Activity in the traces is typical of an academic environment, including software development, document preparation, and mail and bulletin board reading. References not pertinent to the study were filtered using the trace postprocessing software. Details regarding filtering are given in Table 5.9.

status/data and a callback. The disadvantage of check and fetch is lack of performance predictability – a client cannot be certain how much data will be fetched when it sends the RPC request.

Record	Items recorded (with header)
open	flags, mode, file descriptor, index, user ID, old size, size, file type, fid, directory fid, path
close	file descriptor, index, # reads, # writes, # seeks, bytes read, bytes written, size, fid, file type, open count, flags, caller, mode
stat, lstat	fid, file type, path
seek	file descriptor, index, # reads, # writes, bytes read, bytes written, offset
chdir, chroot, readlink	fid, path
execve	size, fid, owner, path
access, chmod	fid, mode, file type, path
creat	fid, directory fid, old size, file descriptor, index, mode, path
mkdir	fid, directory fid, mode, path
chown	owner, group, fid, file type, path
rename	from fid, from directory fid, to fid, to directory fid, size, file type, # links, from path, to path
link	from fid, from directory fid, to directory fid, file type, from path, to path
symlink	directory fid, fid, target path, link path
rmdir, unlink	fid, directory fid, size, file type, # links, path
truncate	old size, new size, fid, path
utimes	access time, modify time, fid, file type, path
mknod	device, fid, directory fid, mode, path
mount	fid, read/write flag, path
unmount	fid, path
fork	child pid, user ID
exit, settimeofday	(header only)
read, write	file descriptor, index, amount
lookup	component fid, parent fid, file type, component path
getsymlink	fid, component path, link path
root	component fid, target fid, path
dump	system call counts
note	annotation

Table 5.7: Contents of Trace Records

This table shows the contents of trace records for each operation. Records corresponding to UNIX system calls are shown in the upper portion of the table. The `lookup`, `root`, and `getsymlink` records are generated during name resolution. The `note` record allows users to embed notes in a trace, for example to indicate a particular point in the execution of an application.

Trace Length	Machine Name	Machine Type	Simulation Start	Trace Records
Work Day (12 hours)	brahms.coda.cs.cmu.edu	IBM RT-PC	25-Mar-91, 11:00	195289
	holst.coda.cs.cmu.edu	DECstation 3100	22-Feb-91, 09:15	348589
	ives.coda.cs.cmu.edu	DECstation 3100	05-Mar-91, 08:45	134497
	mozart.coda.cs.cmu.edu	DECstation 3100	11-Mar-91, 11:45	238626
	verdi.coda.cs.cmu.edu	DECstation 3100	21-Feb-91, 12:00	294211
Full Week (168 hours)	concord.nectar.cs.cmu.edu	Sun 4/330	26-Jul-91, 11:41	3948544
	holst.coda.cs.cmu.edu	DECstation 3100	18-Aug-91, 23:21	3492335
	ives.coda.cs.cmu.edu	DECstation 3100	03-May-91, 12:15	4129775
	messiaen.coda.cs.cmu.edu	DECstation 3100	27-Sep-91, 00:15	1613911
	purcell.coda.cs.cmu.edu	DECstation 3100	21-Aug-91, 14:47	2173191

Table 5.8: Summary of the Work-day and Full-week Traces

These traces were selected from over 1700 collected during February-October 1991. The “Trace Records” column refers to the number of records in each trace during the simulated period (i.e., between simulation-start and simulation-start plus 12 or 168 hours). All of the traces except the Concord trace are of single-user workstations. Concord was used as a timesharing compute-engine. Source: Kistler [62], Table 8.1, page 207.

Attribute	Filter Value
<i>opcode</i>	open close stat lstat chdir chroot creat mkdir access chmod readlink getsymlink chown utimes truncate rename link symlink unlink rmdir lookup root
<i>file type</i>	regular, directory, link
<i>reference count</i>	1
<i>error</i>	0 (success)
<i>matchfds</i>	match closes with corresponding opens
<i>start time</i>	simulation start
<i>end time</i>	trace length
<i>pids</i>	exclude activity by Venus

Table 5.9: Trace Filter Specification

The DFSTrace analysis library allows traces to be filtered by a variety of attributes including operation, pathname, start time, and end time. This table shows the attributes on which the traces are filtered. References to device files, and special files such as `/dev/null` are excluded, as well as unsuccessful operations. The start time is given by the “Simulation Start” column of Table 5.8, and the end time is 12 or 168 hours later as appropriate. The reference count specifier filters out all close records except the final one for a file, as that is when Venus performs activity such as writing CML records. Activity by Venus itself, such as management of local container files, is excluded by specifying the process id of Venus in each trace.

5.4.2 Venus Simulator

The traces were used as input to a Venus simulator. To derive the timing of log optimizations, the simulator must model the cache management responsibilities of Venus. Writing and validating such a simulator is a difficult task at best. To avoid this, Venus was modified to act as its own simulator. In simulator mode, Venus is driven by requests from a trace instead of the operating system. All network access, disk access, and communication with the operating system is stubbed out. Modifications that would normally occur in RVM take place in virtual memory. All volumes are placed in emulating state; updates are logged. The simulator output includes the state of the CML at the end of the trace, and data on cancelled CML records.

The traces reference file systems other than Coda. For the purposes of simulation, all objects referenced in the trace are treated as if they were in the distributed file system. File systems outside of Coda are mapped into separate Coda volumes. The simulator assumes there are no cache misses; if an object unknown to Venus is referenced, the simulator implicitly creates it, but does not generate any explicit file system activity in the simulation.

5.4.3 Results

This section presents several sets of results showing the impact of the aging window on the effectiveness of log optimizations. The analysis assumes throughout that records are reintegrated as soon as they become old enough, and that all reintegrations succeed. These assumptions render the aged CML records immune to further optimization. The section begins with an analysis of the “base case”, in which results are normalized with respect to a maximum aging window of four hours. If a weak connection is available, it is likely that a user will make use of it periodically for the reasons listed at the beginning of this chapter, but in particular to reduce the probability of data loss. The four hour maximum represents half a typical working day, and is a reasonable upper bound on the amount of work loss a user might be willing to tolerate. The goal of this analysis is to find a default aging window that yields 50% effectiveness. That is, the default A should enable the client to optimize half of the CML data that it would if it were disconnected for the entire four hour period. The analysis that follows shows that 50% effectiveness can be achieved with a default aging window of 10 minutes.

The remainder of the section presents a sensitivity analysis of two parameters. The first parameter is the size of the maximum aging window. Instead of measuring the effectiveness of log optimizations with respect to a four-hour window as in the base case, this part of the analysis compares the amount of optimization at a given A to that possible over the entire length of the trace (12 or 168 hours). Since more optimizations are possible over the longer period, one would expect the value of A that yields 50% effectiveness to be larger than that for the base case.

The second parameter is the set of files assumed to reside in the distributed file system. The base case includes all file references in the traces, other than those excluded by the filter given in Table 5.9. In particular, the base case includes references to `/tmp`, which would normally reside in the local file system. Previous work on file reference patterns shows that temporary files tend to be both short-lived and small [39]. Their short lifetimes suggest they would be likely candidates for optimization, and might therefore skew the base case results towards a smaller aging window. On the other hand, their small size may render their effect on the amount of data saved insignificant.

The analysis shows that these perturbations do not change the conclusions of the base case analysis significantly. In all cases, the default value exceeds the median window for 50% effectiveness.⁹ To achieve 50% effectiveness for all ten traces, the aging window would have to be 11 minutes for the base case. If the maximum window is equal to the full length of the trace, the 50% mark is reached at 18 minutes; the increase is due to one of the week-long traces. If temporary files are excluded, and the four-hour maximum is used, the 50% mark is at 14 minutes. Finally, if temporary files are excluded, and the maximum window is the full length of the trace, the 50% mark is at 48 minutes. The increase is due to three of the week long traces, whose 50% marks are at 30, 34, and 48 minutes, respectively.

5.4.3.1 Base Case

The base case assumes that updates are reintegrated no later than four hours after they are performed. Intuitively, this behavior would occur with a write-disconnected client using an aging window of four hours. For this case, the effectiveness of log optimizations as a function of the aging window is normalized with respect to a maximum four-hour aging window. Table 5.10 shows the CML sizes for each trace, with and without optimizations, for the base case. The optimized section shows the amount of data in the CML at the end of the period traced (full day or work week) using a four-hour aging window. The unoptimized section shows the amount of data in the CML without optimizations; this amount is produced using an aging window of 0. The table shows widely varying numbers of records per trace in both the unoptimized and optimized sections. With the exception of the *ives* trace without optimizations, the majority of data (87% or more) represented by the CML arises from the container files associated with `store` records. Even for the unoptimized *ives* trace, the data size is 65% of the total amount reintegrated.

Figures 5.11 and 5.12 show effectiveness of CML optimizations for base case over the day and week traces, respectively. The graphs show wide variation across traces. An aging window of 300 seconds yields only a 30% effectiveness on some traces, but over 80% on others. Some

⁹The distribution of aging windows at 50% effectiveness has a large range and is skewed towards 0 for all cases. The median is the proper index of central tendency for such data [55].

Trace	Unoptimized				Optimized				
	CML Records	CML Size (MBytes)	Data Size (MBytes)	Total (MBytes)	CML Records	CML Size (MBytes)	Data Size (MBytes)	Total (MBytes)	
<i>Day traces</i>									
brahms	2424	0.6	19.4	20.0	1424	0.3	4.9	5.2	
holst	4120	0.9	10.9	11.8	325	< 0.1	0.9	1.0	
ives	846	0.2	2.1	2.3	232	< 0.1	0.7	0.8	
mozart	2469	0.6	8.5	9.1	877	0.2	1.3	1.5	
verdi	554	0.1	41.0	41.2	112	< 0.1	10.4	10.4	
<i>Week traces</i>									
concord	35332	7.9	858.5	866.4	3480	0.8	48.7	49.5	
holst	36890	8.1	62.4	70.5	2974	0.7	29.6	30.2	
ives	175381	40.5	75.0	115.5	11662	2.7	28.1	30.8	
messiaen	8523	1.9	199.1	201.0	2351	0.5	48.9	49.4	
purcell	8872	2.0	92.8	94.8	3843	0.9	50.2	51.1	

Table 5.10: Unoptimized and Optimized CML Sizes, Base Case

This table shows the unoptimized and optimized CML sizes at the end of each file reference trace for the base case. The “CML Size” columns give the total size of records in the CML. The “Data Size” columns give the amount of data in the container files of `store` records; this is the amount of data backfetched. The “Total” columns show the sums of the corresponding “CML Size” and “Data Size” figures. The unoptimized and optimized figures bound the amount of data reintegrated. A client reintegrates the unoptimized amount with an aging window of 0, and the optimized amount with an aging window of four hours.

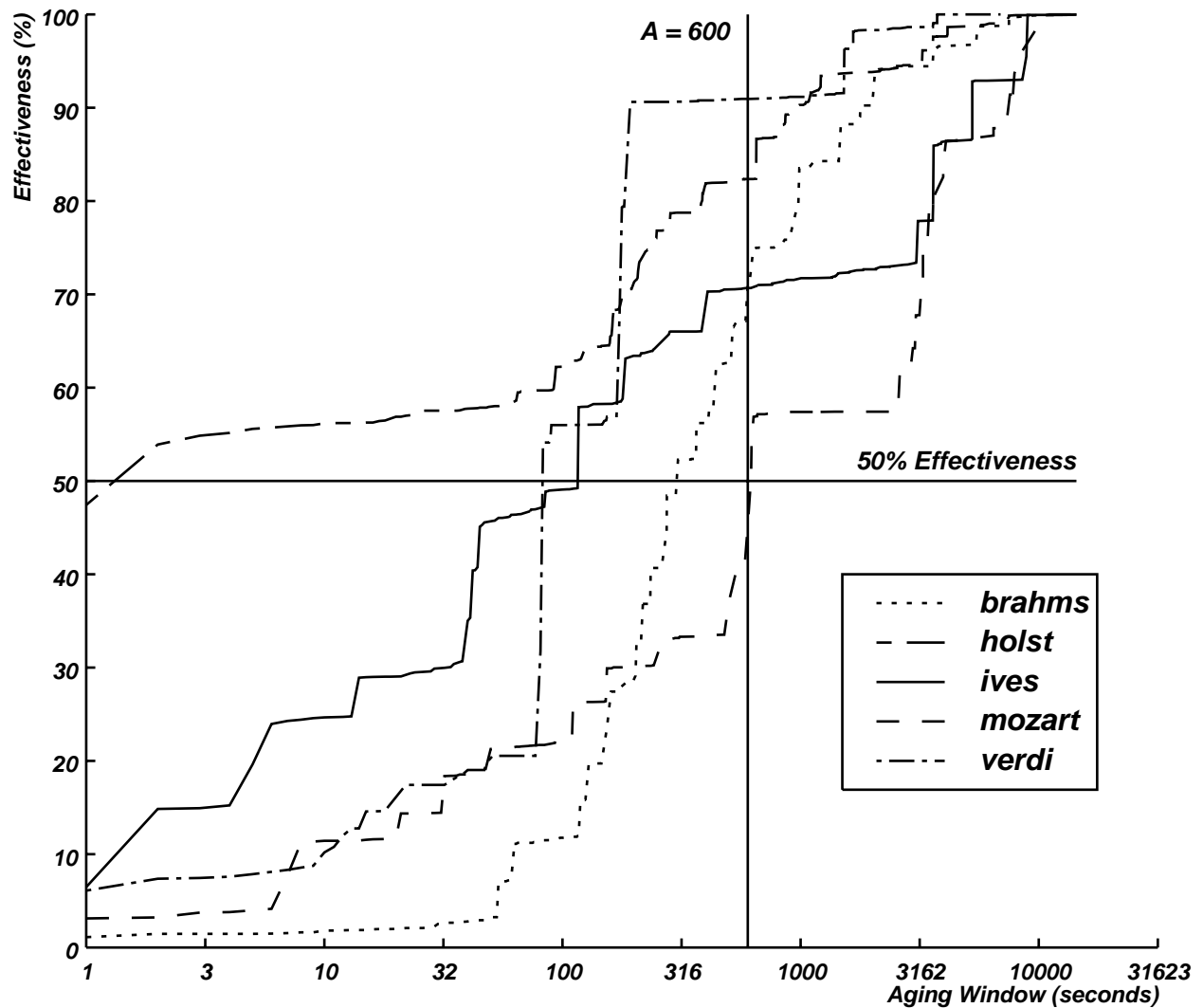

Figure 5.11: Effect of Aging on CML Optimizations, Base Case, Day Traces

This figure shows the cumulative distribution of CML data ages at optimization for the day-long traces.

Note A , the aging window, is shown log scale. The graph is normalized with respect to a four-hour maximum aging window. Each point on a curve is a ratio of two quantities. The numerator is the amount of data saved by optimizations for the value of A at that point. The denominator is the savings when A is four hours (14400 seconds). The value of the denominator is the difference between the unoptimized and optimized totals in Table 5.10.

The default aging window and 50% effectiveness lines shown divide the graph into quadrants. The default aging window is 50% effective if the lower right hand quadrant of the graph is empty.

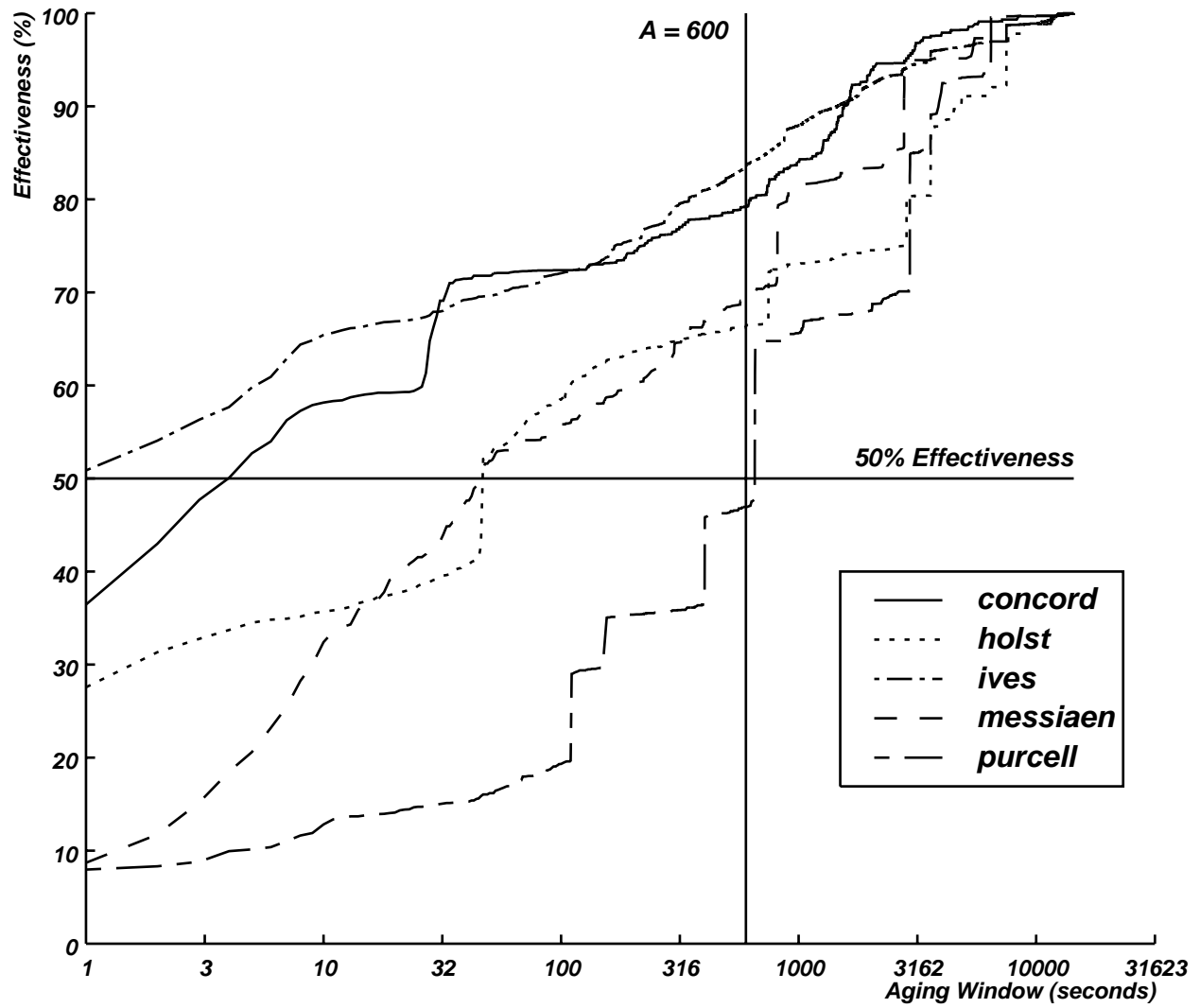

Figure 5.12: Effect of Aging on CML Optimizations, Base Case, Week Traces

This figure shows the cumulative distribution of CML data ages at optimization for the week-long traces. All other conditions are as in Figure 5.11.

of the distributions have long tails: to reach 80% effectiveness on all traces, the aging window must be over one hour. For 50% effectiveness, the aging window ranges from 1 – 655 seconds, with a median of 65 seconds. An aging window of 600 seconds yields over 65% effectiveness for eight of the ten traces. For the remaining two traces, the *mozart* day trace and the *purcell* week trace, the effectiveness is 45% and 47%, respectively. Since 600 seconds yields nearly 50% effectiveness on all traces for the base case, it was chosen as the default value for *A*. In the figures, the default aging window is 50% effective if the lower right hand quadrant of the graph is empty.

5.4.3.2 Full-Length Aging Window

In this case, the client is considered disconnected for the entire trace, and log optimizations may occur at any time during that period. Table 5.13 shows the CML sizes at the end of each trace, with and without optimizations. The unoptimized section is the same as in Table 5.10. The optimized section shows the amount of data in the CML at the end of the period traced (full day or work week). The optimized amounts for four of the day traces are virtually identical to those in Table 5.10. The exception is the *verdi* trace, whose optimized size is less than half that obtained with respect to a four hour aging window. The difference is due to the cancellation of two *store* records for a Venus binary (then just over 3MB) at approximately six hours of age. The optimized data amounts for the week traces are all significantly lower than those in Table 5.10; they vary from 31–82% of the optimized amounts for the base case. This is not surprising, because a week-long trace provides much more time for optimizations to occur. As before, the majority of the data in the optimized logs arises from container files associated with *store* records.

Figures 5.14 and 5.15 show the effectiveness of CML optimizations with respect to the CML size at the end of the day and week traces, respectively. Note that the X axes for Figures 5.14 and 5.15 have different scales than the graphs for the base case. For 50% effectiveness, the aging window ranges between 2 – 1040 seconds, with a median of 199 seconds. The default aging window yields 51–82% effectiveness for eight of ten traces. The exceptions are the *mozart* day trace and the *purcell* week trace. At 600 seconds the *mozart* day trace shows 45% effectiveness; it reaches the 50% mark at 620 seconds. The *purcell* day trace shows 35% effectiveness at 600 seconds; it requires 1040 seconds to reach 50% effectiveness. Overall, the lower right-hand quadrants of Figures 5.14 and 5.15 show that the default window yields nearly 50% effectiveness on nine of the ten traces.

Compared to the base case, the full length aging window made little difference for four of the five day traces. The exception was the *verdi* trace, whose aging window for 50% effectiveness jumped from 83 to 174 seconds. The latter window is still much smaller than the default. Not surprisingly, the week traces were affected more by a full-length aging window than the day traces. The aging window for 50% effectiveness increased significantly for three of the five

week traces, *holst*, *messiaen*, and *purcell*. Only the window for *purcell* is larger than the default aging window.

5.4.3.3 No /tmp Files

This case assumes that /tmp resides in the local file system, and thus excludes trace references to it and its descendants. It preserves the maximum four-hour aging window as in the base case. Table 5.16 shows the CML sizes for each trace with respect to the maximum aging window of four hours, excluding references to /tmp. The table shows significantly lower unoptimized log sizes for most traces (compared to Table 5.10). In particular, the *concord* trace had over 200 MB less data (a decrease of 28%). As before, the vast majority of data is from the container files associated with `store` records. This decrease in log sizes illustrates the amount of update activity to /tmp in the traces. However, the optimized log sizes differed little from the base case for all but two traces. The *verdi* day trace had 3.1 MB less data without /tmp files (a decrease of 30%), and *messiaen* week trace had 4.0 MB less data (a decrease of 8%). These observations confirm that much of the activity to /tmp is subject to optimization.

Figures 5.17 and 5.18 show the effectiveness of CML optimizations with respect to a four hour maximum aging window, excluding /tmp files. For 50% effectiveness, the aging window ranges from 1–813 seconds, with a median of 215 seconds. The default aging window yields 58–85% effectiveness on seven of ten traces. The remaining three traces, the *mozart* day trace, the *messiaen* week trace, and the *purcell* week trace were all close to 50%, at 45%, 46%, and 45% respectively.

Compared to the base case, the graphs show considerably lower effectiveness for small aging windows. For example, at a 30 second aging window, the median effectiveness drops from a 35% (range 3–77%) in the base case to 14% (range 1–65%) without /tmp files. This decrease is consistent with short /tmp file lifetimes.

5.4.3.4 Full-Length Aging Window, No /tmp Files

This case excludes references to /tmp its descendants, and considers the client disconnected for the entire traced period. Table 5.19 shows the unoptimized and optimized log sizes at the end of each trace, excluding references to /tmp. Because updates to /tmp files are excluded, the unoptimized log sizes are smaller than in the full-length window case of Section 5.4.3.2. The optimized log sizes are virtually identical. Because optimizations have the full length of the trace to occur, the optimized log sizes are smaller for the *verdi* trace and the week traces compared to the four-hour aging window case without /tmp files of Section 5.4.3.3.

Figures 5.20 and 5.21 show the effectiveness of CML optimizations excluding references to /tmp. Note that the X axes for these graphs have different scales than the graphs for the base

Trace	Unoptimized				Optimized				
	CML Records	CML Size (MBytes)	Data Size (MBytes)	Total (MBytes)	CML Records	CML Size (MBytes)	Data Size (MBytes)	Total (MBytes)	
<i>Day traces</i>									
brahms	2424	0.6	19.4	20.0	1424	0.3	4.9	5.2	
holst	4120	0.9	10.9	11.8	318	< 0.1	0.9	1.0	
ives	846	0.2	2.1	2.3	210	< 0.1	0.7	0.8	
mozart	2469	0.6	8.5	9.1	873	0.2	1.3	1.5	
verdi	554	0.1	41.0	41.2	103	< 0.1	4.1	4.1	
<i>Week traces</i>									
concord	35332	7.9	858.5	866.4	1851	0.4	16.1	16.5	
holst	36890	8.1	62.4	70.2	1661	0.4	17.5	17.9	
ives	175381	40.5	75.0	115.5	7204	1.7	23.7	25.4	
messiaen	8523	1.9	199.1	201.0	1157	0.3	15.1	15.4	
purcell	8872	2.0	92.8	94.8	2671	0.6	35.8	36.4	

Table 5.13: Unoptimized and Optimized CML Sizes, Full Trace Length

This table shows the unoptimized and optimized CML sizes at the end of each file reference trace. The unoptimized CML sizes are the same as in Table 5.10. The “CML Size” columns give the total size of records in the CML. The “Data Size” columns give the amount of data in the container files of `store` records; this is the amount of data backfetched. The “Total” columns show the sums of the corresponding “CML Size” and “Data Size” figures. The unoptimized and optimized figures bound the amount of data reintegrated. A client reintegrates the unoptimized amount with an age of 0, and the optimized amount with an age of 12 hours or 168 hours for the day-long and week-long traces, respectively.

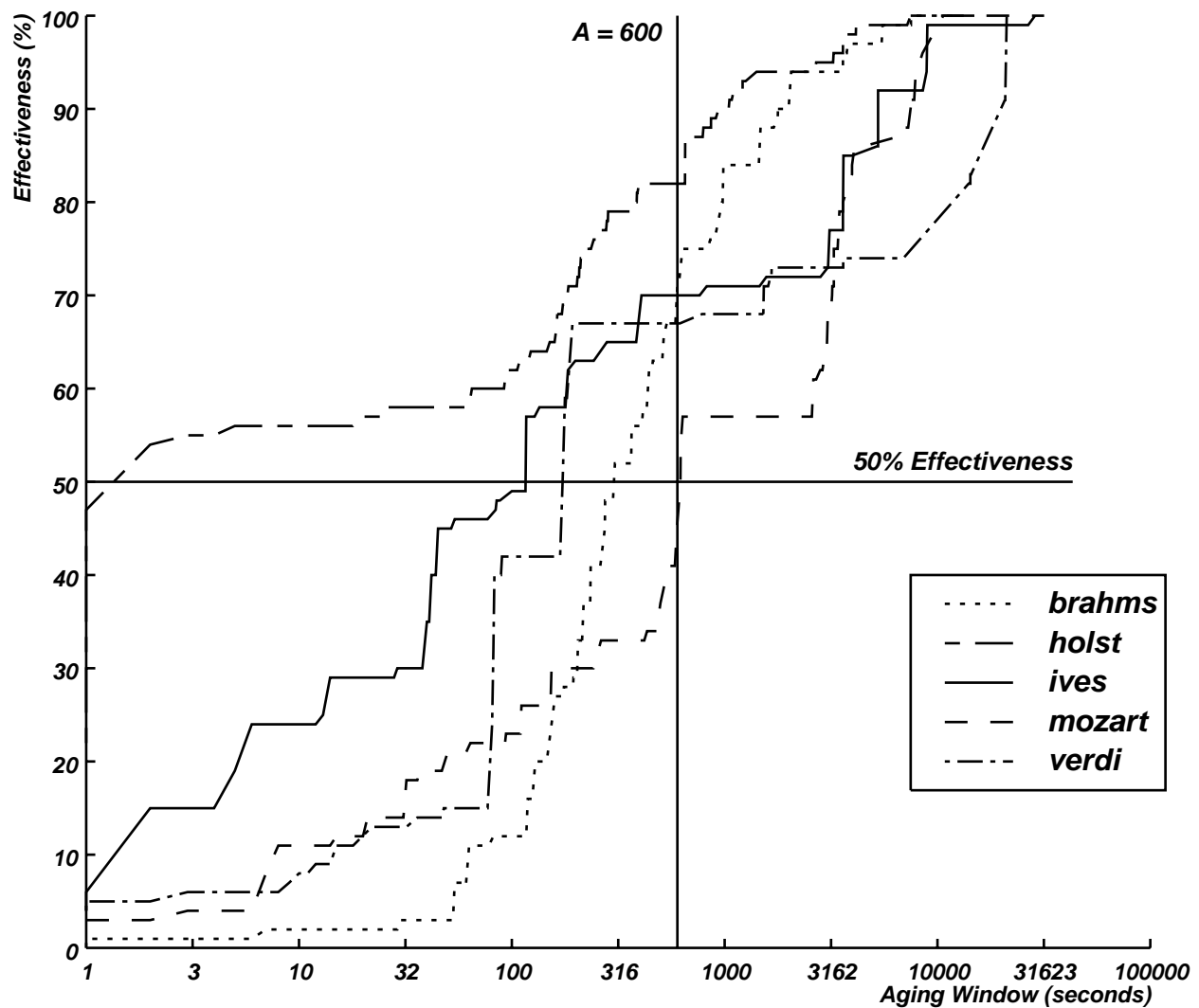

Figure 5.14: Effect of Aging on CML Optimizations, Day Traces

This figure shows the cumulative distribution of CML data ages at optimization for the day-long traces. The maximum age is 43200 seconds (12 hours).

Note A , the aging window, is shown log scale. The effectiveness is the ratio of the amount of data optimized for the trace at A to the total amount of data optimized for the trace. The total amount of data optimized is the difference between the unoptimized and optimized totals in Table 5.13.

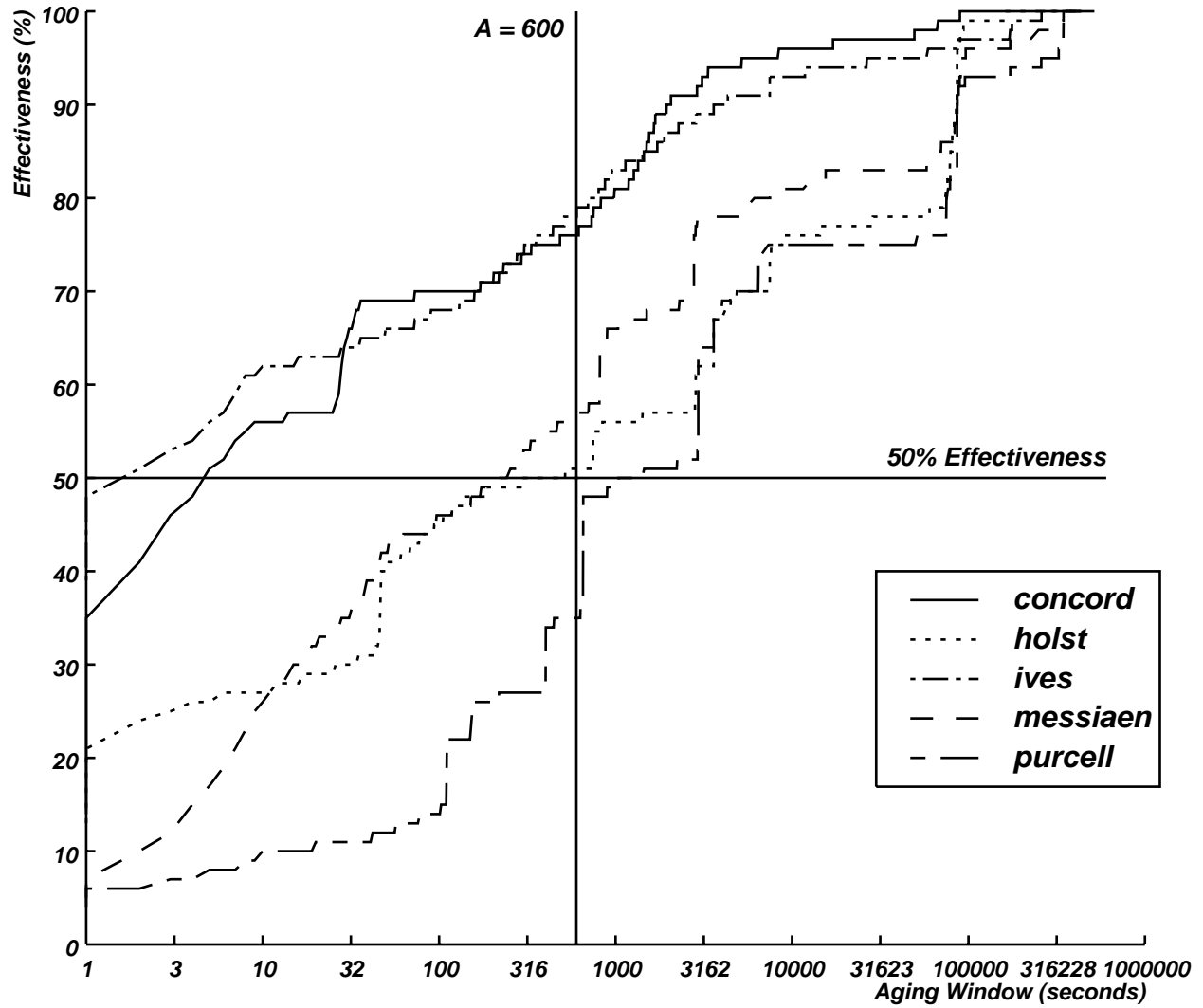

Figure 5.15: Effect of Aging on CML Optimizations, Week Traces

This figure shows the cumulative distribution of CML data ages at optimization for the week-long traces. The maximum age is 604800 seconds (168 hours). All other conditions are as in Figure 5.14.

case. For 50% effectiveness, the aging window ranges from 2–2851 seconds, with a median of 275 seconds. The default aging window yields at least 50% effectiveness for six of the traces. Exceptions are the *mozart* day trace, and the *holst*, *messiaen*, and *purcell* week traces. The *mozart* day trace was close, at 45% effectiveness; it reaches the 50% mark at 623 seconds.

Compared to the base case, the median effectiveness is again significantly lower for small aging windows. At 30 seconds, the median effectiveness drops from 35% (range 3-77%) in the base case to 11% (range 1-61%). At 600 seconds, there is little difference for the day traces, but the effectiveness is lower for the three week traces mentioned previously.

5.5 Chapter Summary

This chapter describes trickle reintegration, the mechanism Venus uses to propagate updates performed at a weakly connected client. Trickle reintegration propagates updates in a best effort manner, as network availability and bandwidth allows. At the same time, it conserves network usage by delaying propagation to take advantage of updates that cancel or overwrite each other. Because update propagation over a weak connection can be a lengthy process, it is important that trickle reintegration be unobtrusive; that is, it must not interfere with foreground activity at the client. The evaluation of trickle reintegration, in Section 7.5, will show that it achieves this goal.

Trace	Unoptimized				Optimized				
	CML Records	CML Size (MBytes)	Data Size (MBytes)	Total (MBytes)	CML Records	CML Size (MBytes)	Data Size (MBytes)	Total (MBytes)	
<i>Day traces</i>									
brahms	2166	0.5	19.4	19.9	1424	0.3	4.9	5.3	
holst	2020	0.5	5.5	5.9	313	< 0.1	0.8	0.9	
ives	712	0.2	1.8	2.0	227	< 0.1	0.7	0.8	
mozart	2010	0.5	8.4	8.9	875	0.2	1.3	1.5	
verdi	350	< 0.1	31.4	31.5	98	< 0.1	7.3	7.3	
<i>Week traces</i>									
concord	15206	3.4	624.6	628.0	3477	0.8	48.7	49.5	
holst	32505	7.1	54.6	61.7	2848	0.6	29.6	30.2	
ives	159198	36.8	71.4	108.2	11585	2.7	27.9	30.6	
messiaen	5632	1.3	122.2	123.5	2331	0.5	44.9	45.4	
purcell	7574	1.7	91.1	92.8	2665	0.9	50.2	51.1	

Table 5.16: Unoptimized and Optimized CML Sizes, Excluding /tmp, Four Hour Maximum

This table shows the unoptimized and optimized CML sizes as in Table 5.10, except references to /tmp are excluded.

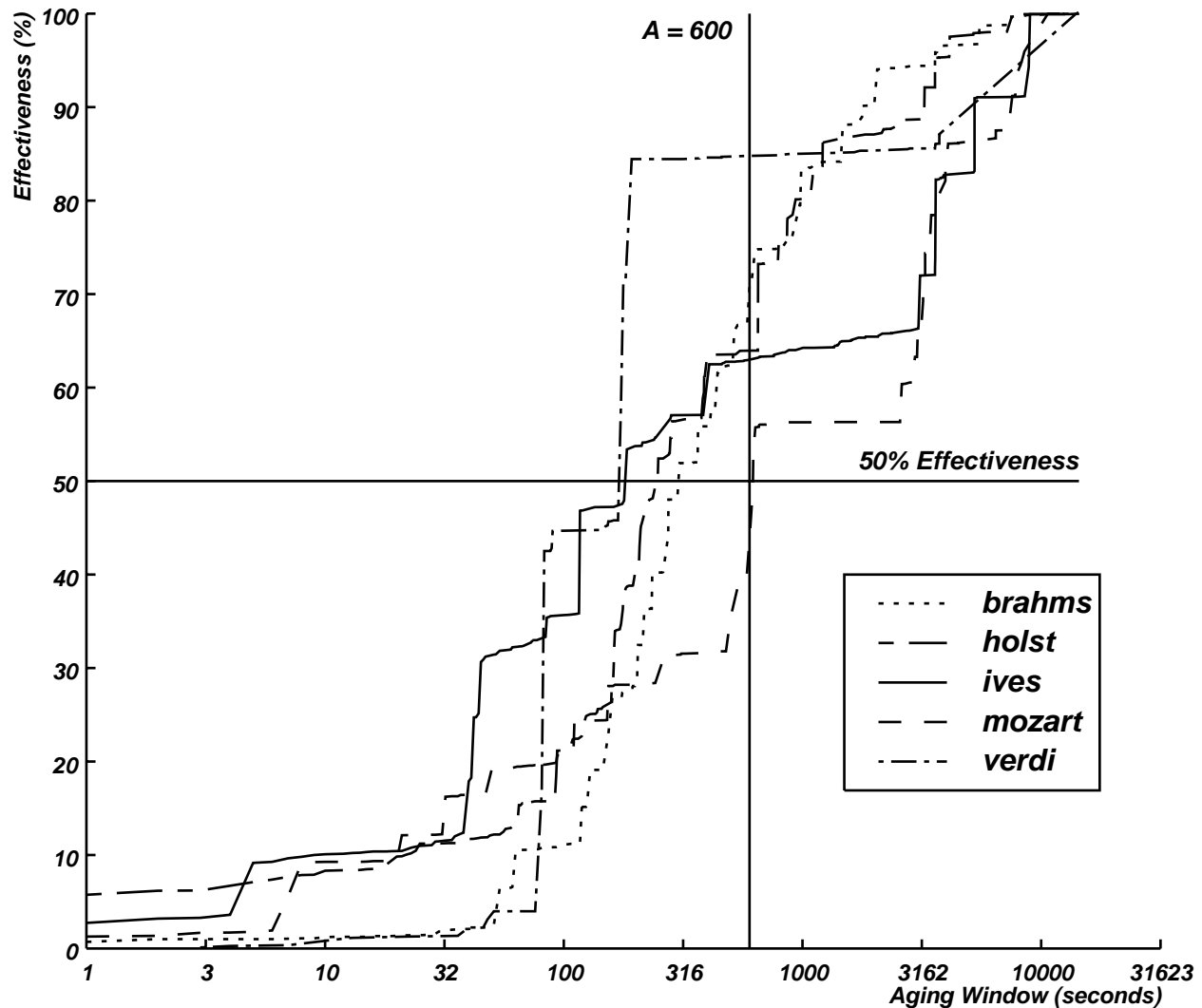

Figure 5.17: Effect of Aging on CML Optimizations, Excluding $/tmp$, Four-Hour Maximum, Day Traces

This figure shows the cumulative distribution of CML data ages at optimization, excluding files in $/tmp$, for the day-long traces.

The graph is normalized with respect to a four-hour maximum aging window. Each point on a curve is a ratio of two quantities. The numerator is the amount of data saved by optimizations for the value of A at that point. The denominator is the savings when A is four hours (14400 seconds). The value of the denominator is the difference between the unoptimized and optimized totals in Table 5.16.

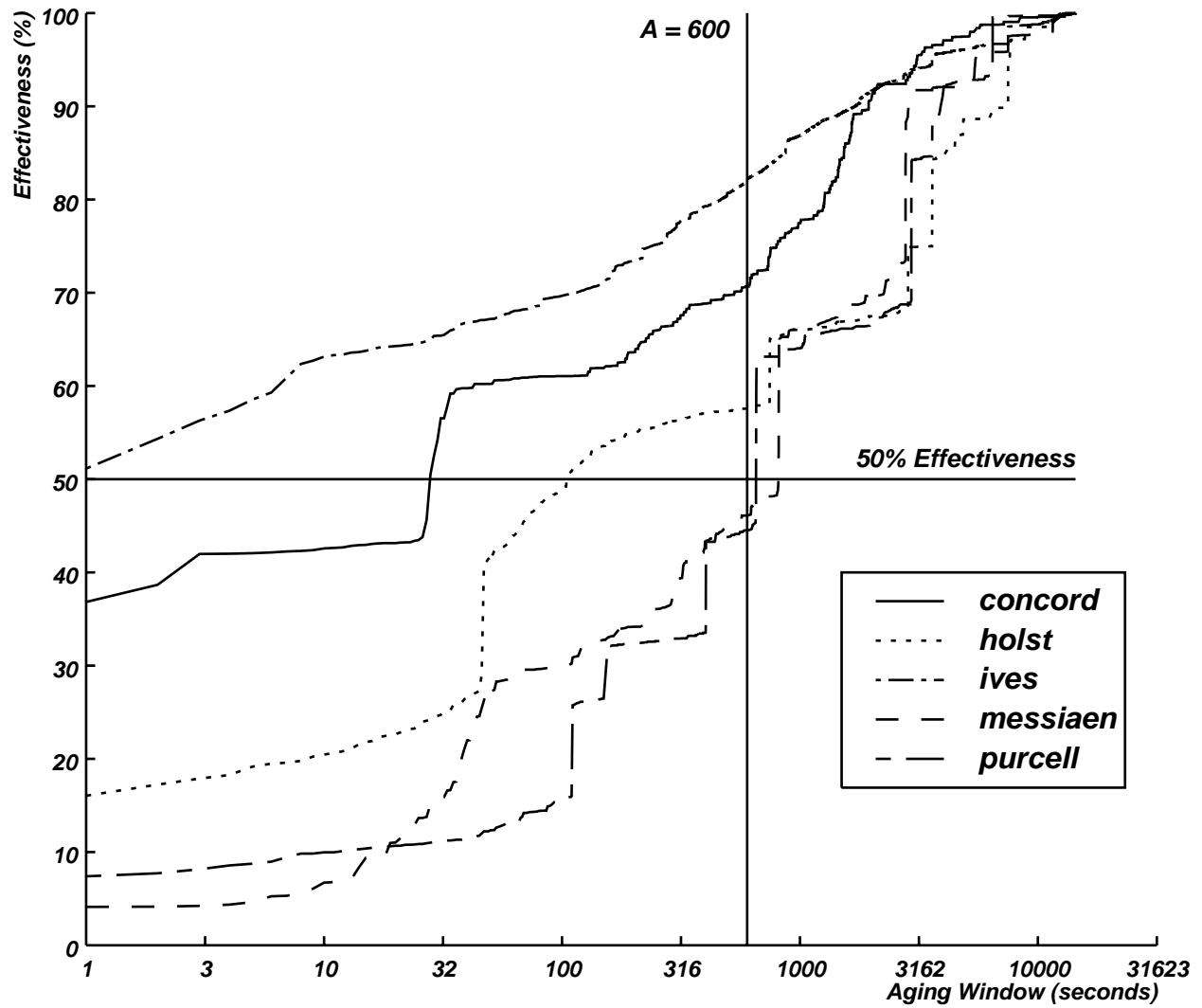

Figure 5.18: Effect of Aging on CML Optimizations, Excluding /tmp, Four-Hour Maximum, Week Traces

This figure shows the cumulative distribution of CML data ages at optimization, excluding files in /tmp, for the week-long traces. All other conditions are as in Figure 5.17.

Trace	Unoptimized				Optimized				
	CML Records	CML Size (MBytes)	Data Size (MBytes)	Total (MBytes)	CML Records	CML Size (MBytes)	Data Size (MBytes)	Total (MBytes)	
<i>Day traces</i>									
brahms	2166	0.5	19.4	19.9	1424	0.3	4.9	5.3	
holst	2020	0.5	5.5	5.9	306	< 0.1	0.8	0.9	
ives	712	0.2	1.8	2.0	205	< 0.1	0.7	0.8	
mozart	2010	0.5	8.4	8.9	871	0.2	1.3	1.5	
verdi	350	< 0.1	31.4	31.5	92	< 0.1	4.1	4.1	
<i>Week traces</i>									
concord	15206	3.4	624.6	628.0	1848	0.4	16.1	16.5	
holst	32505	7.1	54.6	61.7	1549	0.3	17.5	17.9	
ives	159198	36.8	71.4	108.2	7193	1.7	23.7	25.4	
messiaen	5632	1.3	122.2	123.5	1148	0.3	14.7	15.0	
purcell	7574	1.7	91.1	92.8	2668	0.6	35.8	36.4	

Table 5.19: Unoptimized and Optimized CML Sizes, Excluding /tmp, Full Trace Length

This table shows the unoptimized and optimized CML sizes as in Table 5.13, except references to /tmp are excluded.

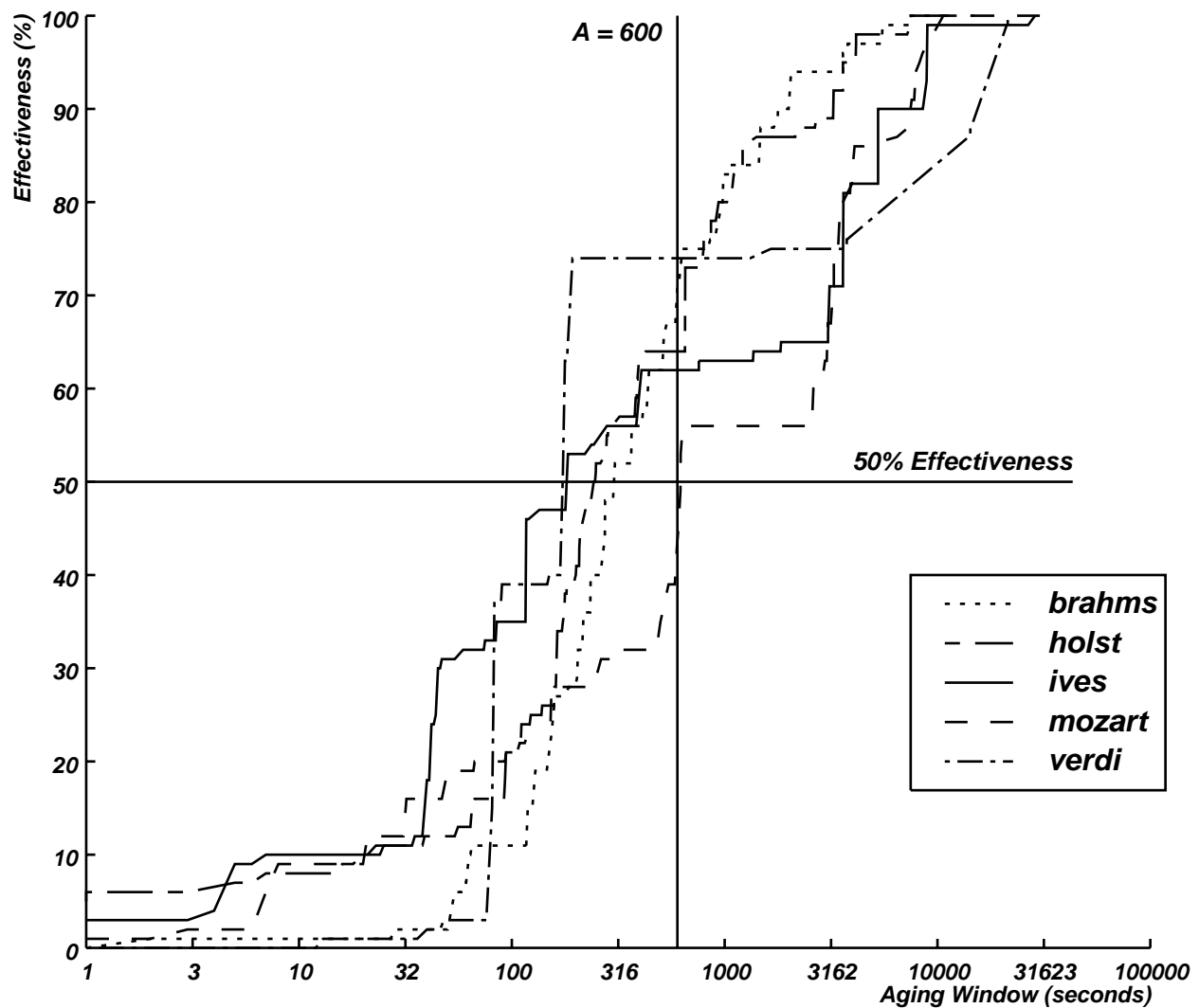

Figure 5.20: Effect of Aging on CML Optimizations, Excluding /tmp, Day Traces

This figure shows the cumulative distribution of CML data ages at optimization, excluding files in /tmp, for the day-long traces.

Each point on a curve is a ratio of two quantities. The numerator is the amount of data saved by optimizations for the value of A at that point. The denominator is the savings at the end of the trace. The value of the denominator is the difference between the unoptimized and optimized totals in Table 5.19.

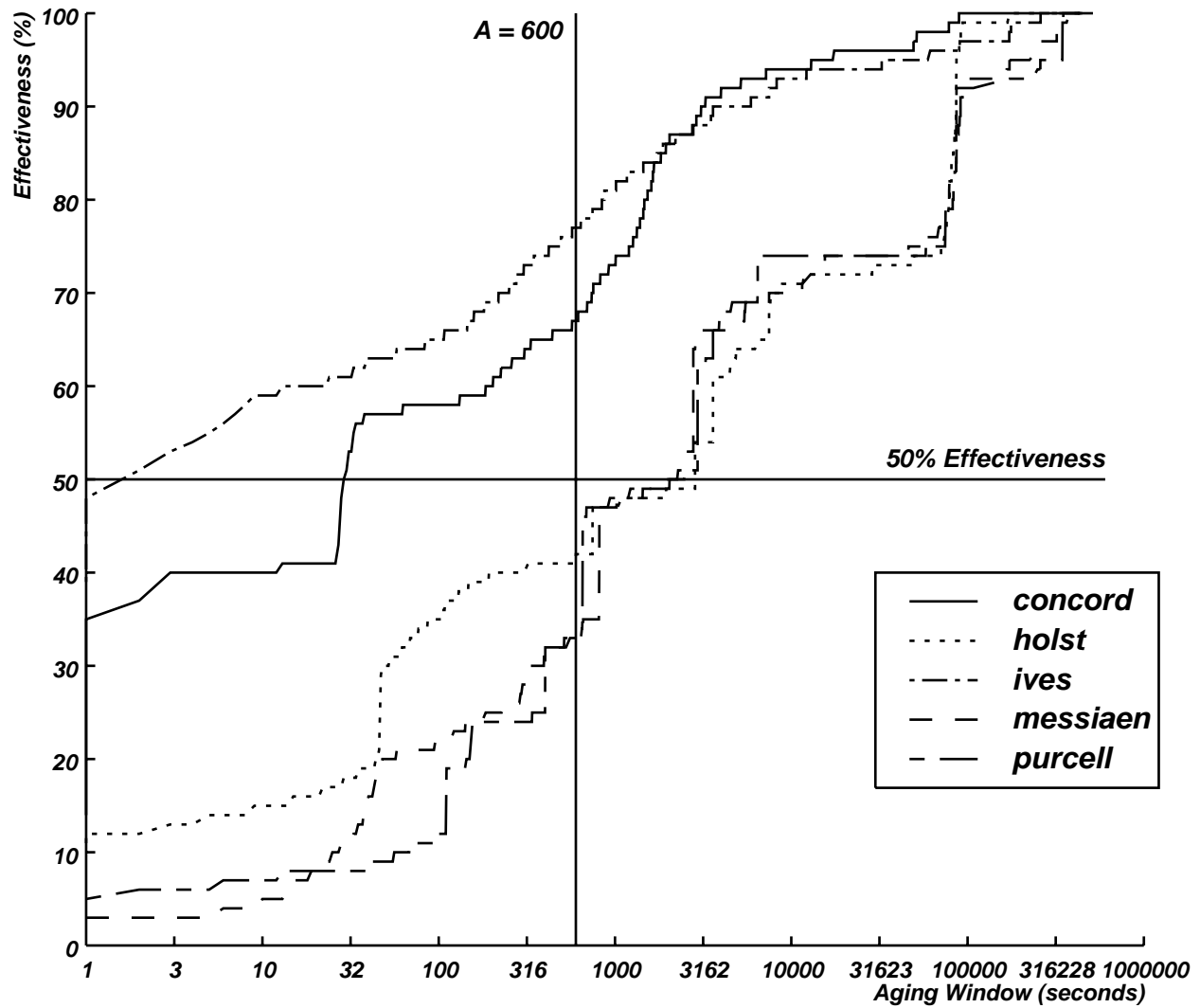

Figure 5.21: Effect of Aging on CML Optimizations, Excluding /tmp, Week Traces

This figure shows the cumulative distribution of CML data ages at optimization, excluding files in /tmp, for the week-long traces. All other conditions are as in Figure 5.20.

Chapter 6

Handling Cache Misses

As connectivity weakens, the performance penalty of cache misses becomes too large to ignore. From a user's perspective, this lack of performance transparency can overshadow the functional transparency of caching. For example, a cache miss on a 1 MB binary at 10 Mb/sec can usually be serviced in a second or two. At 9.6 Kb/sec, the same miss causes a delay of nearly 20 minutes! In most cases, a user would rather be told that the file is missing than be forced to wait a substantial time for it. But there are also situations where a file is so critical that a user is willing to suffer this delay. The maximum delay a user is willing to tolerate for a particular file is called his *patience threshold* for that file.

How can Venus decide whether or not to service a cache miss while weakly connected? As the penalty for suboptimal decisions increases, so does the value of user advice. Venus uses *a priori* advice on a file's importance as input to a model that determines the user's patience threshold for the file. In cases where the servicing of a cache miss is still questionable, Venus solicits the user for advice through an interactive facility called the *advice monitor*. User advice is optional: if the client is unattended, or if a user does not run an advice monitor, Venus operates from a set of default actions.

This chapter describes mechanisms for handling cache misses while weakly connected. The user assistance mechanisms are part of a more general framework by Ebling [35]; this chapter describes how that framework is applied to weak connectivity. The chapter begins by describing the advice monitor. It then shows how a user can interact with the system to control the amount of data fetched during cache miss servicing and hoard walks. The final section delves into the underlying patience model.

6.1 Advice Monitor

The advice monitor is a user-level process that serves as a liaison between the user and Venus. Through the advice monitor, a user may selectively enable different kinds of advice or request information about various aspects of the system, and Venus may solicit advice or notify the user of important events. The advice monitor and Venus communicate using RPC2; relevant interface calls are listed in Table 6.2. The code for user interaction is implemented in Tcl/Tk [94] and requires that the user be running the X window system. Figure 6.1 shows the process structure and flow of information for a typical user interaction. In this example, an event occurs within Venus that prompts it to ask for advice. The thread making the request is blocked until the user responds.

The functionality of the advice monitor could be provided as part of Venus. However, there are several advantages to implementing it as a separate process. First, it minimizes additions to Venus, which is already both large and complex. Modifications to Venus for user advice are limited for the most part to hooks. Second, development and testing of the advice monitor can proceed independent of Venus. The main disadvantage of a separate process implementation is higher latency for operations involving user advice. This is not a serious drawback, because interactions are exceptional events, and their latency is likely to be overwhelmed by user think time.

The advice monitor runs on behalf of a particular user. There are two reasons for this approach. First, since the advice monitor exposes information on a user's file references, it is important to restrict access to such information for security reasons. Second, the advice monitor pesters the user for advice regarding only the activity for which she is responsible.

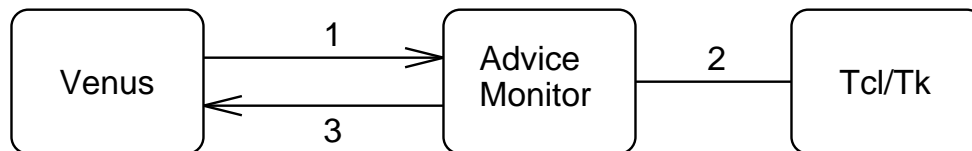

Figure 6.1: Advice Monitor Interaction

This figure shows the communication between processes involved in a user advice interaction on a client. An event occurs within Venus for which it requires advice. It sends an RPC request to the advice monitor (1), which in turn executes the Tcl/Tk interpreter with a script for the interaction (2). Once the user responds, the advice monitor replies to the RPC with the result of the interaction (3).

Operation	Description
NewAdviceService	Called the first time an advice monitor contacts Venus
ConnectionAlive	Determine if Venus is reachable
RegisterInterest	Selectively enable or disable advice
SetParameters	Set Venus parameters dynamically
ImminentDeath	Called on advice server shutdown
HoardWalkAdvice	Request advice about which objects to fetch during a hoard walk
WeaklyConnectedMiss	Request advice on whether or not to service a cache miss while weakly connected
LostConnection	Clean up connection state from previous advice monitor invocation

Table 6.2: Advice Monitor Interfaces

This table shows the RPC interfaces between Venus and the Advice Monitor pertinent to weakly connected operation. The top section of the table shows calls made by the Advice Monitor to Venus, and the bottom section shows calls made by Venus to the Advice Monitor.

Although it is possible for different users to thwart each others efforts at limiting the amount of data fetched, in practice clients are single-user workstations or notebook computers.

6.2 User Interactions

The user interactions pertinent to weak connectivity come in three forms. Two of them are prompted by Venus on hoard walks and certain cache misses, and one is initiated by the user to augment the hoard database with data on recent cache misses.

6.2.1 Handling Cache Misses

The cache miss handling mechanism allows users to selectively suppress the servicing of demand cache misses while weakly connected. (Cache misses caused by the hoard subsystem are handled by a separate mechanism, described in Section 6.2.3.) When a cache miss occurs, Venus estimates the time needed to service it. This estimate is based on the size of the object,



Figure 6.3: Weakly Connected Miss

The Advice Monitor displays this screen when the estimated fetch time for a file exceeds the patience threshold. The screen is triggered by receipt of a `WeaklyConnectedMiss` RPC.

obtained from the object's status information, and the current bandwidth to its VSG. If Venus does not already have status information about the object cached, it obtains that information from the VSG. The delay for this is acceptable even on slow networks because status information is only about 100 bytes long.

The estimated service time is then compared with the patience threshold, whose calculation is described in Section 6.3. If the service time is below the threshold, Venus transparently services the miss. If the threshold is exceeded, Venus queries the user through the advice monitor by displaying the screen shown in Figure 6.3. The user may choose to suppress the fetch; in that case Venus returns an error to the calling application. If the user does not respond to the screen within 15 seconds, Venus fetches the file. In this case, the client is likely unattended, and the file may be needed later. If an advice monitor is not running, Venus automatically fetches the file. The decision process for handling cache misses is illustrated in Figure 6.4.

6.2.2 Augmenting the HDB

At any time, a user can ask the advice monitor to display all of the unserved cache misses that have occurred since the previous such request. The advice monitor displays each miss along with contextual information, as shown in Figure 6.5. The advice monitor records information on unserved cache misses internally; it does not need to contact Venus to generate the list of cache misses. The user can select which, if any, of the missing objects should be added to the HDB. The advice monitor then sends a request to Venus to add the objects to the HDB, just as the `hoard` program does. Venus does not fetch the objects immediately – that is deferred until a future `hoard` walk. By default, `hoard` walks occur in the background once every 10 minutes, but the user can force a foreground `hoard` walk at any time.

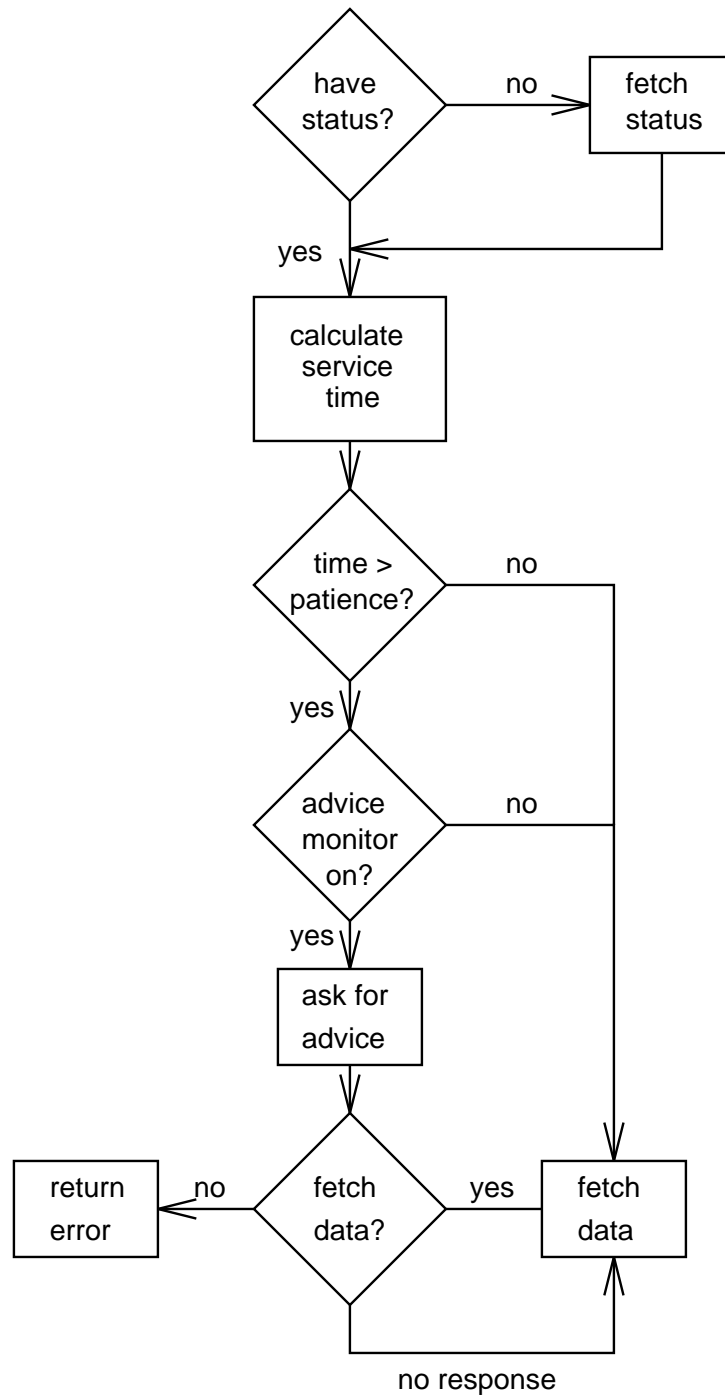

Figure 6.4: Cache Miss Handling

This figure illustrates the decision process for weakly connected cache miss handling, explained in Section 6.2.1.

File/Directory	Program	HDB?
/coda/usr/satya/papers/s15/s15.mss	head (1)	<input type="checkbox"/>
/coda/project/coda/alpha/real.src/venus/fso0.c	gnu-emacs (<input type="checkbox"/>
/coda/misc/tex/i386_mach/alpha/bin/virtex	-sh (1)	<input type="checkbox"/>

Figure 6.5: Augmenting the Hoard Database

This screen, displayed in response to a user's request to see recorded cache misses, shows the name of each missing object, the program that referenced it, and the number of misses incurred on the file by instances of the program. To add an object to the HDB, the user clicks the button to its right. A pop-up form, shown in Figure 6.6 allows the user to specify the hoard priority of the object and other related information.

Pathname: /coda/project/coda/alpha/real.src/venus/fso0.c

Hoard Priority

20

+

Figure 6.6: Specifying an HDB Entry

This pop-up form is displayed when the user requests that a missing object be added to the HDB from the screen in Figure 6.5. For directories, the user may include children or descendants by clicking the appropriate buttons. Clicking the "+" button indicates that the specification will apply to future children or descendants of the directory as well.

6.2.3 Controlling Hoard Walks

A hoard walk is executed in two phases. In the first phase, called the *status walk*, Venus obtains status information for missing objects and determines which objects, if any, should be fetched. The status walk usually involves little network traffic. During the second phase, called the *data walk*, Venus fetches the contents of objects selected by the status walk. If there are many large objects to be fetched, this phase can be a substantial source of network traffic.

An interactive phase between the status and data walks allows a user to limit the volume of data fetched in the data walk. For each object selected during the status walk, Venus estimates its fetch time based on its size and the current bandwidth to its VSG. Those objects whose fetch times fall below the user's patience threshold are pre-approved for fetching, and Venus fetches them automatically during the next data walk. The fetching of other objects must be explicitly approved by the user.

Venus solicits advice from the user by issuing a `HOARDWALKADVICE` RPC to the advice monitor between the status and data walks. The advice monitor displays a screen like the one in Figure 6.7. The screen allows users to select the objects to be fetching during the data walk. If no input is provided by the user within 3 minutes, the screen disappears and the data walk fetches all objects listed. The user input timeout is much longer than in the cache miss interaction because the user may need more time to examine the list of objects. Of course, if the advice monitor is not running, the screen is not displayed, and Venus fetches all objects selected by the status walk.

6.3 Patience Model

The simplest approach to characterizing a user's patience threshold (τ) is to use a single, user-selectable number. For example, with τ set at 2 seconds, only misses that would take less than 2 seconds are transparently handled. Implementing such a policy would be trivial. But as mentioned earlier, τ really depends on how important a user perceives an object to be: for a very important object, the user is probably willing to wait many minutes. Since user perception of importance is exactly the notion captured by the hoard priority P of an object, we hypothesize that τ should be a function of P . The challenge is to determine and validate the functional form and parameters of this relationship.

At the present time, we are not aware of any data that would enable us to scientifically screen potential candidates for this functional form. Hence the current implementation uses a function based solely on intuition, but this function can easily be replaced if a better alternative becomes available. We conjecture that patience is similar to other human processes such as vision and hearing, whose sensitivity is logarithmic [22]. This leads to a relationship of the form $\tau = \alpha + \beta e^{\gamma P}$, where β and γ are scaling parameters and α represents a lower bound on

Cache Files: Allocated = 6250 Occupied = 389 Available = 5861					
Cache Space (KB): Allocated = 50000 Occupied = 8244 Available = 41756					
Speed of Network Connection (b/s) = 9600					
Number of Objects Preapproved for Fetch = 3					
Object Name	Priority	Cost (s)	Fetch?	Stop Asking?	
/coda/project/coda/alpha/src/venus/fso0.c	20	48	<input type="checkbox"/>	<input type="checkbox"/>	
/coda/misc/emacs/i386_mach/bin/emacs	600	611	<input type="checkbox"/>	<input checked="" type="checkbox"/>	
Total Expected Fetch Time (s) = 65					
Total Number of Objects to be Fetched = 4					
Cache Space (KB) After Walk: Alloc'd = 50000 Occ'd = 8301 Avail = 41699					
Cancel				Done	

Figure 6.7: Controlling the Data Walk

This screen enables the user to selectively suppress fetching of objects during a hoard walk. The hoard priority and estimated service time of each object are shown. The user approves the fetch of an object by clicking on its "Fetch" button. By clicking on its "Stop Asking" button, she can prevent the prompt and fetch for that object until strongly connected. At the bottom of the screen is the cache status that would result from the data walk. This information is updated as the user clicks on "Fetch" buttons.

patience. Even if an object is unimportant, the user prefers to tolerate a delay of α rather than interacting with the system. Intuitively, the value of α should be at least the time it takes for Venus and the advice monitor to display the cache miss window, and for the user to respond to it. The default parameter values are $\alpha = 2$ seconds, $\beta = 1$, and $\gamma = 0.01$, but they may be changed by the user. The default values result in plausible patience values for many files commonly found in the hoard profiles of Coda users.

Figure 6.8 illustrates the patience model. The patience threshold τ is expressed in terms of the size of the largest file that can be fetched in that time at a given bandwidth. For example, for a patience threshold of 60 seconds, the largest file that can be fetched at a bandwidth of 64 Kb/sec is 480KB. Each curve in Figure 6.8 shows τ as a function of P for a given bandwidth. The region below a curve represents those combinations of file sizes and hoard priorities for which caches misses are transparently handled and pre-approval is granted during hoard walks. For example, a cache miss on the 1 MB file is serviced transparently, regardless of priority, if the bandwidth exceeds 2 Mb/sec. But at 9.6 Kb/sec, it is serviced transparently only if it is hoarded at high priority.

6.4 Chapter Summary

This chapter has described mechanisms for more intelligent handling of cache misses while weakly connected. These mechanisms are motivated by the fact that the servicing of a cache miss over a weak connection is not necessarily transparent. The high variability in performance has rendered caching *translucent*. The system exposes caching to the user in cases where preserving transparency would harm usability. That is, it selectively relaxes transparency when necessary, and does so in a way that minimally impacts the user. This chapter has focused on a specific instance of a more general problem: how can a system decide whether or not to act transparent? Work by Ebling [35] is exploring how best to relax transparency while preserving usability.

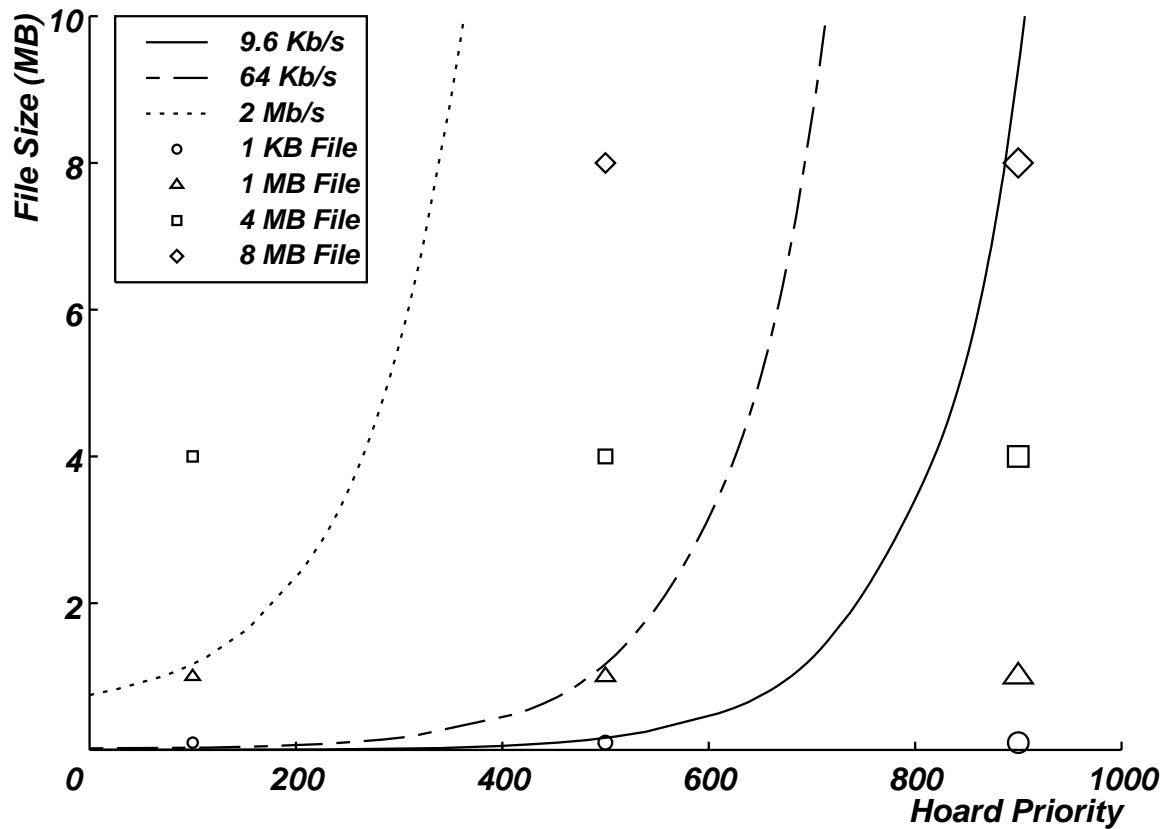

Figure 6.8: Patience Threshold versus Hoard Priority

Each curve in this graph expresses patience threshold, (τ), in terms of file size, as discussed in Section 6.3. Superimposed on these curves are points representing files of various sizes hoarded at priorities 100, 500, and 900. At 9.6 Kb/sec, only the files at priority 900 and the 1KB file at priority 500 are below τ . When bandwidth rises to 64 Kb/sec, the 1MB file at priority 500 also falls below τ . At 2Mb/sec, all files except the 4MB and 8MB files at priority 100 are below τ .

Chapter 7

Evaluation

The mechanisms for weak connectivity described in this thesis have been implemented and deployed as part of the Coda file system. This chapter presents a quantitative evaluation of the transport protocol, rapid cache validation, and trickle reintegration mechanisms. The evaluation is based on controlled experimentation and empirical data gathered from the deployed system in everyday use. This chapter begins with the status of the implementation and a description of the usage environment.

7.1 Evolution and Implementation Status

The mechanisms for weak connectivity were deployed in stages starting in 1993. The first stage involved enabling the transport protocols to operate at low bandwidths. Early anecdotal evidence from Coda indicated that users of disconnected operation often wanted to make their updates visible to collaborators after a period of working disconnected, and they felt more comfortable when the results of many hours of hard work were safely stored on a server. These concerns were significant enough that users sometimes came in to work just to reintegrate. The ability to reintegrate over a phone line addressed both of these concerns.

Serious use of reintegration by phone soon revealed that it was much slower than even the most pessimistic estimates. Examination of network traffic and Venus code revealed that cache validation traffic, which is barely perceptible on a LAN, had substantial impact on a slow network. It was especially painful when connections were intermittent. For slivers of connectivity to be useful, it is imperative that cache validation occupy a negligible fraction of each sliver. Batching validation requests on a single RPC helped speed up validation, but not enough. The rapid cache validation mechanism was then implemented in late 1993 and deployed in early 1994.

The next stage extended Venus to operate write-disconnected. In this state, Venus logged updates as if it were disconnected, but continued to service cache misses as if it were connected. Entry into and exit from this state was done via explicit commands. A user stayed connected continuously, operating mostly write-disconnected, but occasionally forcing reintegration. Lapses in a user's hoarding strategy, resulting in cache misses, were functionally masked. Once write-disconnected mode was operational, the manual triggering of reintegration was eliminated with the trickle reintegration mechanism. Trickle reintegration was developed in late 1994 and released for general use in 1995. Early versions of trickle reintegration propagated data to all AVSG members regardless of connection strength. To conserve bandwidth over weak connections, users partitioned their clients from all but one server, reintegrated with it, and then manually triggered resolution to propagate the updates to all AVSG members. The implementation was refined in 1996 to reintegrate with one server while weakly connected and trigger resolution automatically, and to check data versions of objects to eliminate unnecessary refetching of data after resolution.

The last stage was to substantially improve the handling of cache misses when weakly connected. Examination of misses showed that they ranged in importance from critical to banal, and arose from a wide range of causes. Fully automating the handling of misses appeared unlikely to be satisfactory. Instead, users were provided contextual information about misses, and given opportunity to influence their handling. The user assistance mechanism was developed in early 1995, and has been released for general use. The mechanism continues to be refined and extended by Maria Ebling as part of her work [35].

7.2 Usage Environment

Coda has been in daily use by a community of Coda developers and other computer science researchers since 1991. At the time of this writing, there are ten Coda servers housing approximately 4.0GB of data. The servers are all DECstation 5000/200 series workstations running Mach 2.6 [1]. Three of these servers comprise a production VSG, and three a beta-test VSG. The remaining four servers are used for alpha testing, and hold volumes of varying replication factors. Each of the three groups runs different releases of the server software.

The servers collectively store 270 volumes. About 30% of these volumes are *user volumes*, which store users' private data. Eighteen of the user volumes are *object volumes*, used in addition to home volumes to store the results of compilations. Most user volumes are stored on the production servers. The main exception is object volumes, which are stored on the beta servers. Object volumes are good stress tests for the beta servers because they result from real user activity and object files are relatively easy to regenerate in case a catastrophic bug strikes. Another 14% are *system volumes*, which are used to store application software, such as editors, window managers, compilers, and document processing tools, as well as Coda binaries. System

volumes also form the top levels of the Coda name space. About one third of the system volumes are stored on the production servers; the rest reside on the beta servers. *Project volumes* hold data used in collaborative work, such as the Coda system source areas. Project volumes account for 40% of all volumes, and are generally stored on the production servers. The remaining volumes are *test volumes*, used for system stress testing and demonstration purposes. Test volumes are stored on the alpha servers.

There are 50 Coda user accounts, of which about 25 are used regularly. There are about 45 clients, evenly divided between desktop and notebook computers. All clients run Mach 2.6, although the Coda client software has been ported to Mach 3.0 [42], and ports are underway to NetBSD and LINUX [8]. Most workstations are DECstation 5000/200s, although there are a few DECstation 3100s and Intel i386-based machines. The notebook computers are all Intel i486-based. Until December 1995, they were almost entirely DEC pc425SLs. Now about two thirds of them are IBM Thinkpad 701cs. Many users run Coda on both their desktop workstations and their notebook computers.

The environments for desktops and notebooks differ with respect to Coda. For the desktops, most system and application software is supplied by AFS. Hence they tend not to use the Coda system areas. The notebook computers do not have access to AFS, and were configured this way for two reasons. First, the notebooks were intended for mobile use, and AFS lacked support for disconnected operation. Second, disk space on notebooks was limited, and could not support both AFS and Coda caches. (This is no longer true – the new notebooks have more disk space than our desktops!) The notebooks access application software from the Coda system areas, and most notebook users store their home directories and environment files in their Coda user volume.

7.3 Transport Protocol

The addition of round trip timing to RPC2 and SFTP means the protocols do more work when processing packets. The obvious question is then: Is transport protocol performance acceptable with round trip timing? To answer this question, file transfer performance was compared to that of the most widely used transport protocol available under Mach 2.6, namely TCP [99].

File transfers were performed using three different network configurations: a 10 Mb/s Ethernet, a 2 Mb/s WaveLan wireless network, and a modem operating at 9.6 Kb/s over a phone line using SLIP. The configurations are shown in Figure 7.1. The experiment consisted of disk-to-disk transfers of a 1 MB file using RPC2/SFTP and FTP [100] between a DECpc 425SL notebook and a DEC 5000/200 workstation.

The observed throughput, based on end-to-end transfer times, is shown in Table 7.2. The results show that RPC2 and SFTP perform well over a wide range of network speeds. In



(a) Ethernet

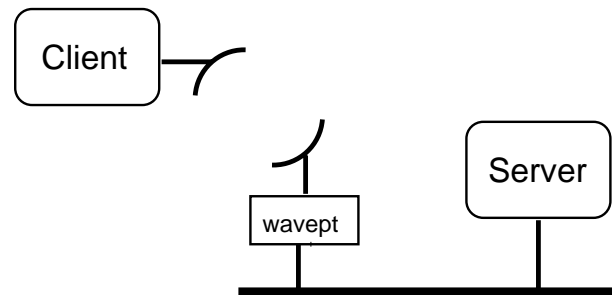

(b) Wavelan

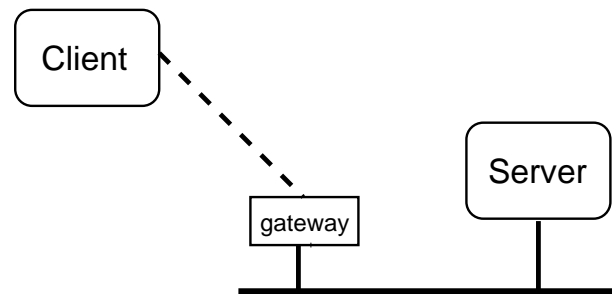

(c) Modem

Figure 7.1: Experiment Configuration

This figure shows the three configurations used in the evaluation of the transport protocol. The experiments were conducted using a DEC pc425SL notebook client and a DECstation 5000/200 server, both with 32 MB of memory, running Mach 2.6. The client and server shared an isolated network. In the WaveLan configuration, the server was connected via Ethernet to a Wavepoint. In the Modem configuration, the client dialed an Intel i486-based workstation, which acted as a SLIP gateway.

Transfer Direction	Network	Nominal Speed	TCP		RPC2/SFTP		
			(KB/sec)	% Nom.	(KB/sec)	% Nom.	
Send	Ethernet	10 Mb/s	300	(28)	24	343 (12)	27
	WaveLan	2 Mb/s	95	(10)	38	146 (6)	58
	Modem	9.6 Kb/s	0.80	(0.005)	69	0.86 (0.003)	73
Receive	Ethernet	10 Mb/s	228	(8)	18	244 (13)	19
	WaveLan	2 Mb/s	71	(17)	28	144 (8)	58
	Modem	9.6 Kb/s	0.85	(0.008)	72	0.82 (0.002)	70

Table 7.2: Transport Protocol Performance

This table compares the observed throughput of TCP and RPC2/SFTP. The data was obtained by timing the disk-to-disk transfer of a 1MB file between a DECpc 425SL notebook client and a DEC 5000/200 server over an isolated network. Both client and server were running Mach 2.6. Each result is the mean of five trials. Numbers in parenthesis are standard deviations. The “% Nom.” column gives the percentage of the nominal bandwidth used by the file transfer, based on the mean observed throughput.

almost all cases, SFTP’s performance equals or exceeds that of TCP. However, this end-to-end evaluation does not reveal the individual contributions of the various techniques used in RPC2 and SFTP (e.g., round trip timing, calculation of retransmission intervals, retransmission strategy), only the effect of the collection of techniques as a whole. Therefore, one cannot determine from this evaluation the correctness or relative importance of the design decisions made; one can only conclude that the combination of those decisions resulted in reasonable performance for the experiment in question.

Opportunities abound for further improvement to the transport protocols. For example, they could perform header compression as proposed for TCP [53]. Or, SFTP could be enhanced to ship file differences rather than entire file contents. But the focus of this work has been at higher levels of the system, with minimal efforts at the transport level. Further transport level improvements may enhance higher level mechanisms, but cannot replace them.

7.4 Rapid Cache Validation

Two questions best characterize the evaluation of Coda’s rapid cache validation mechanism. First, under ideal conditions, how much do volume callbacks improve cache validation time? Second, in practice, how close are conditions to ideal? This section addresses both questions.

7.4.1 Performance Under Ideal Conditions

For a given set of cached objects, the time for validation is minimal when two conditions hold. First, at disconnection, callbacks must exist for all volumes represented in the cache. Second, while disconnected, the volumes containing these objects must not be updated at the server. Then, upon reconnection, communication is needed only to verify volume version stamps. Fresh volume callbacks are acquired as a side effect, at no additional cost.

Under ideal conditions, the primary determinants of performance are network bandwidth and the composition of cache contents. This section describes experiments conducted to measure validation time as a function of these two variables.

7.4.1.1 Methodology

The figure of merit for these experiments is the time required to validate a client's cache after a failure, or the *cache recovery time*. Obviously, the cache recovery time depends on the cache contents. For these experiments, the cache contents are based on the hoard profiles of five Coda users, summarized in Table 7.3. The profiles were chosen to represent a range of user activity and expertise. These profiles are used primarily for notebooks.

The experiments were performed with a single client and server, both DECstation 5000/200s with 32 MB of memory, running Mach 2.6. The client used a 50 MB Coda file cache. The machines were connected via Ethernet. Emulation of slower networks and failure injection was performed by a package which intercepts outgoing packets and suppresses or delays them according to a *filter*. For example, the filter might specify that request packets to a certain host be dropped with some probability, or delayed as if the network were a lower speed. The delay is a simple-minded calculation, and does not take into account overheads such as UDP and IP header sizes, or IP fragmentation. A comparison of RPC latency for emulated and real 9.6Kbps links is shown in Table 7.4. The filter package is linked into Venus and the server, and requests to insert and remove filters are issued via RPC.

For each experiment, the client's hoard database was initialized with the hoard profiles for a single user, and the cache filled by a hoard walk. Each run of the experiment consisted of the following steps:

- Partition the client from the server by inserting filters that specify all packets between the two to be dropped.
- At the client, check server status. (The client times out on the server and declares it down.)
- Heal the partition by removing the filters.
- At the client, check server status. (The client discovers the server is up.)
- Run a hoard walk to validate cache entries.

Volume Type	Number of Files Cached				
	User 1	User 2	User 3	User 4	User 5
X11	38	127	133	125	142
T _E X			560	158	
System	9	6	190	342	689
Cboard					361
Other tools		42	13	13	42
Coda binaries			2	6	4
Coda sources			4	549	6
Kernel sources					24
User 1 personal	114				
User 2 personal		234			
User 3 personal			190		
User 4 personal				220	6
User 5 personal					537
Other personal	107	4	5	10	10
Total files	268	413	1097	1423	1821
Total volumes	7	6	9	11	12
Cache size (MB)	2.4	16.5	9.2	37.3	22.3

Table 7.3: Contents of Hoard Profiles for Five Coda Users, by Volume

This table characterizes the contents of the hoard profiles for five Coda users. Entries represent the number of objects hoarded from each volume by each user.

The system type represents volumes containing system binaries, utilities, and include files. Cboard is a project volume for a calendar program; its maintainer is user 5. “Other tools” refers to five volumes containing utilities such as GNU-Emacs and less. The “Coda binaries” volume contains Coda-related programs that many users hoard. The “Coda sources” category is of interest primarily to Coda developers. It consists of two volumes containing scaffolding for the project tree, libraries, include files, and sources. User 4’s personal files are split into a home volume and a volume solely for object files. “Other personal” is a set of five volumes belonging to users other than the ones we studied. Two of those volumes contain versions of `kermi`t that most users hoard, and one contains a popular window manager.

Packet Size	Time (seconds)	
	Emulated	Real
60	.11 (.01)	.33 (.01)
260	.43 (.03)	.76 (.04)
560	.96 (.01)	1.4 (.0)
1060	1.8 (.0)	3.3 (2.6)
2060	3.5 (.0)	4.6 (.28)
3060	5.2 (.0)	6.6 (.0)
4060	7.9 (1.9)	8.7 (.0)

Table 7.4: Emulated versus Real RPC at 9.6 Kbps

This table compares the RPC latency using the network emulator set to 9.6 Kbps over an Ethernet, and using a dialup SLIP link nominally rated at 9.6 Kbps. RPC request and response packets were the same size. The experiments were conducted using an i386-based IBM L40 notebook client and a DECstation 5000/200 server, both running Mach 2.6. RPC packet headers are 60 bytes long; the first line gives the times for a null RPC. Each entry is the mean and standard deviation for the most consistent eight trials from a set of ten. The large standard deviations for 4060 bytes (emulated) and 1060 bytes (real) were due to retransmissions during one or more runs.

The recovery time was taken from the time at which the client noticed the server was up to the end of the hoard walk. Since the experiment was conducted under ideal conditions, no updates occurred on cached volumes at the server by any other client during the partition.

The experiments measured cache recovery times for four network speeds and three validation strategies for each user. The network speeds were 10 Mb/sec, representing Ethernet; 2 Mb/sec, representing packet radio (such as NCR WaveLan); 64 Kb/sec, representing ISDN, and 9.6 Kb/sec, representing a dialup connection. The validation strategies were **NoOpt**, **Batched**, and **VCB**. The **NoOpt** strategy validates an object by fetching its status block from the server and comparing it to the cached copy. This corresponds to the `Vnode` operation `GetAttr` [64]. The **Batched** strategy allows a group of files to be validated in one RPC. This refinement was described in Section 7.1. In Coda, up to 50 fids may be piggybacked with version information on a `GetAttr` request. The **VCB** strategy validates objects by volume using previously cached version stamps. These validations are also batched; for these experiments only one RPC is needed to validate the volumes.

Although the production version of Coda uses the **Batched** strategy, the **NoOpt** strategy was measured for two reasons. First, it allows the results to be compared to file systems that do not batch validations, such as AFS. Second, even though batching takes less time and bandwidth at any speed than **NoOpt**, it has some disadvantages at low bandwidth. Batching can result in large request packets – nearly 3KB in Coda. These request packets have high latency at low bandwidth (see Table 7.4), and retransmissions of these packets can starve other requests, causing Venus to declare servers down. Indeed, such failures occurred during the experiments! It may be more appropriate to use a smaller batching factor for low bandwidth networks. A demand (user) request for one file can result in a batch validation of up to 50 files, which incurs additional latency that could be deferred to background processes.

Batching of volume validations does not have as great an impact on the system as batching of file validations because clients have information on many fewer volumes than files, and volume identifiers and version stamps are much smaller than their counterparts for files.

7.4.1.2 Results

Cache Recovery Time Table 7.5 presents the results of the experiments. The same data is graphically illustrated in Figure 7.6. The results show that for all users, and at all bandwidths, volume callbacks reduce cache recovery time. The variation in recovery time across users is proportional to the number of files cached. The reduction is modest at high bandwidths, but becomes substantial as bandwidth decreases. At 9.6 Kb/sec, where **VCB** is likely to be most important, recovery time takes only 4–7% of the time required by **NoOpt**, and 11–20% of the time required by batching. The results for **VCB** at 9.6 Kb/sec are only 25% longer than for **VCB** at 10Mb/sec, indicating that **VCB** compensates successfully for a three order of magnitude reduction in bandwidth.

Network Speed	Validation Strategy	Recovery Time in Seconds					Relative Times
		User 1	User 2	User 3	User 4	User 5	
10Mb/s	NoOpt	6.8 (.5)	9.9 (.8)	20.9 (.6)	31.5 (.5)	46.0 (1.1)	100.0%
	Batched	2.5 (.5)	3.6 (.5)	8.2 (.5)	11.0 (.0)	19.0 (.8)	38.5%
	VCB	2.5 (.5)	3.5 (.5)	7.4 (.5)	10.0 (1.3)	17.5 (.8)	35.5%
2Mb/s	NoOpt	6.5 (.5)	11.0 (2.6)	21.3 (1.2)	32.0 (.5)	46.0 (.9)	100.0%
	Batched	3.0 (.0)	4.1 (.4)	9.4 (.5)	12.6 (.5)	21.0 (.8)	42.9%
	VCB	2.3 (.5)	3.7 (.5)	7.3 (.5)	9.4 (.5)	18.1 (.8)	34.9%
64Kb/s	NoOpt	12.8 (1.4)	17.5 (.5)	40.9 (1.4)	63.6 (1.6)	87.5 (2.2)	100.0%
	Batched	5.4 (.5)	7.2 (.5)	16.9 (.4)	24.3 (.5)	36.5 (.9)	40.6%
	VCB	2.3 (.5)	4.0 (.5)	7.4 (.5)	9.6 (.5)	17.8 (.9)	18.5%
9.6Kb/s	NoOpt	67.8 (1.4)	102.8 (.9)	226.1 (2.2)	342.4 (4.0)	453.8 (9.7)	100.0%
	Batched	23.8 (2.8)	31.4 (2.5)	80.9 (15.8)	103.1 (9.7)	136.3 (8.7)	31.5%
	VCB	4.8 (.5)	5.3 (.5)	8.9 (.6)	11.3 (.5)	20.3 (.9)	4.2%

Table 7.5: Cache Recovery Time

This table presents the time in seconds needed by a client to validate cached files when it discovers a server is up. The cache contents are determined by the hoard profiles for each of the five users. The rightmost column is the average reduction in validation time compared to NoOpt for each of the other two strategies. The reduction is given as a percentage, and is calculated as $(100 \times t_{\text{Other}}) / t_{\text{NoOpt}}$. These results are conservative in a number of respects, as explained in Section 7.4.1.2.

The experiments were conducted using DECstation 5000/200s running Mach 2.6 as the client and server, and volumes stored at one server. The network speeds correspond to the nominal speeds of Ethernet (10 Mb/s), WaveLan (2 Mb/s), ISDN (64 Kb/s), and Modem (9.6 Kb/s). For the three slower speeds, bandwidth was varied using an emulator on Ethernet. Each entry is the mean and standard deviation (in parentheses) of the most consistent eight trials from a set of ten.

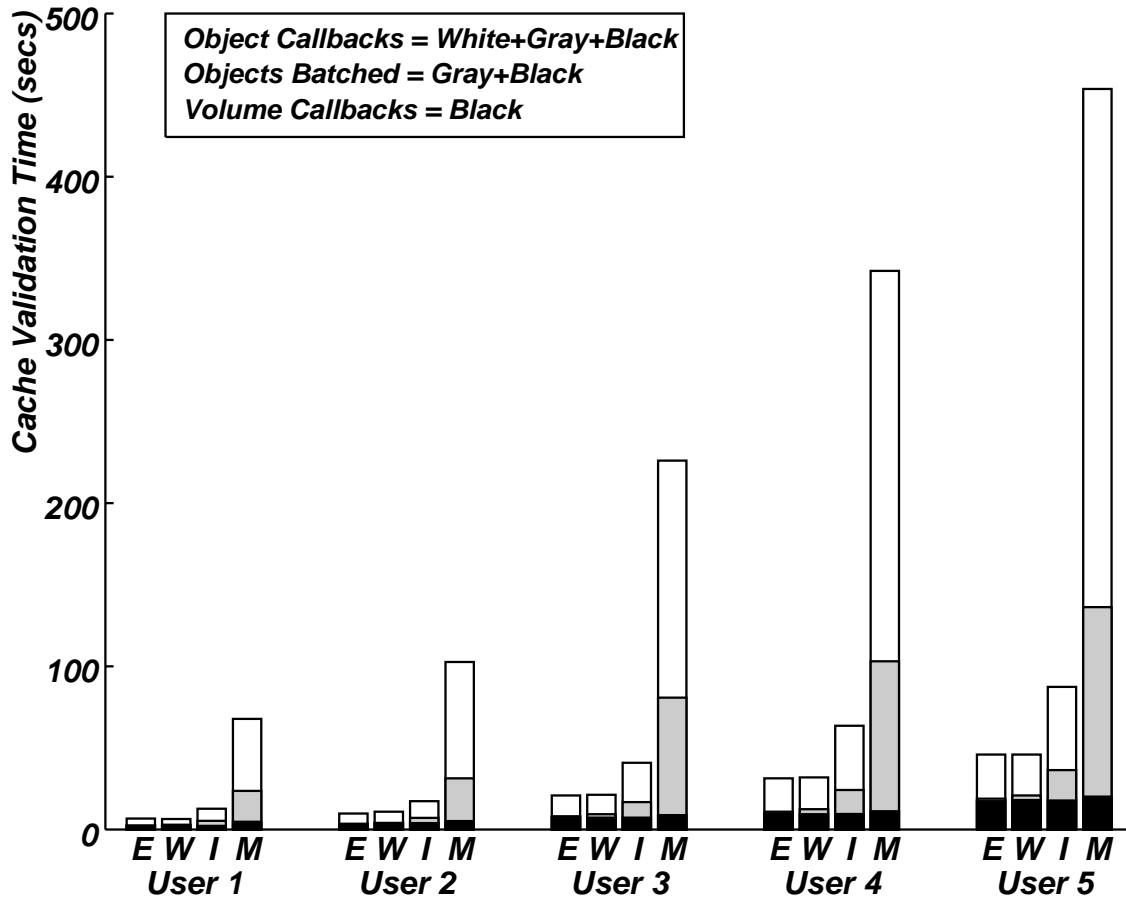

Figure 7.6: Validation Time Under Ideal Conditions

This figure depicts the data presented in Table 7.5. Each of the colored bars (black, gray, and white) represents an entry in the table. The network speeds correspond to the nominal speeds of Ethernet (E, 10 Mb/s), WaveLan (W, 2 Mb/s), ISDN (I, 64 Kb/s), and Modem (M, 9.6 Kb/s).

An unexpected result was that the recovery time using VCB on a slow network was not constant over all users. The network was expected to be the bottleneck in these cases. Since only one RPC was required to validate the volumes, the recovery times should have been similar. Instead, recovery times were proportional to the number of files cached, indicating the bottleneck is Venus. Most of its time is spent on two tasks: marking cached objects suspect when the server appears up, and performing the hoard walk, which involves iterating through all of the objects in the cache to ensure they are valid.

Accuracy of Results The results in Table 7.5 understate the benefits of VCB in a number of respects. First, the failure library underestimates the delay for a given network speed, as shown in Table 7.4. Second, the volumes used in the experiments were singly replicated, while in practice most volumes in Coda are triply replicated. Since many networks do not support multicast, an RPC request to an AVSG with more than one member is sent as separate messages to each member. If the network is the bottleneck, as with the NoOpt and Batched strategies, the time required to validate cached files for each of the strategies in Table 7.5 will be proportionately larger. Last, caches typically contain more than what is hoarded. This occurs for several reasons – name space exploration, objects left over from other tasks, and execution of a task to find files not included by hoard profiles. Each of these effects underestimates the savings due to VCB, especially over low bandwidth networks.

Callback Overhead The number of callbacks at the server can be derived from Table 7.3, from the number of objects and volumes represented by the hoard profiles for each user. In these experiments, clients using the Batched or NoOpt strategies obtain callbacks for each file validated. After a successful recovery, clients using VCB obtain callbacks only for the volumes they validated. The number of callbacks obtained by clients using VCB was less than 3% of the number obtained by the other two strategies.

VCB versus Read-only Replication Read-only replication is a feature of AFS and Coda which allows read-only copies, or *clones*, of volumes to be created to improve availability and balance load [49]. Access to clones is very efficient, because no cache coherence protocol is needed. Read-only replication is useful for volumes which contain files that are frequently read but seldom updated, such as system programs. When a file in a volume with read-only clones is updated, manual intervention is required to create new clones before changes are globally visible. Volume callbacks represent an alternative to read-only volumes for collections of “read mostly” data. In return for modest validation traffic and callback overhead, clients retain the ability to observe updates immediately, without manual intervention.

Desktop Clients	Days Collected	Notebook Clients	Days Collected
bach	240	caractacus	41
berlioz	220	deidamia	128
brahms	167	elijah	12
chopin	189	eroica	52
copland	205	finlandia	183
dvorak	247	genoveva	3
gershwin	91	giselle	2
gs125	39	gloriana	82
handel	115	guntram	84
holst	147	harawi	38
ives	236	hiawatha	168
mahler	197	jupiter	107
messiaen	177	messiah	35
michaelangelo	86	nabucco	79
mootaz	192	oberon	53
mozart	234	phoenix	61
purcell	154	planets	58
schumann	26	porgy	31
varicose	237	prometheus	252
verdi	200	serse	68
vivaldi	12	spartacus	62
		tosca	84
		valkyrie	83
Mean	162	Mean	77

Table 7.7: Mond Clients and Data Collection Length

This table shows the hosts from which data was collected via mond, and the collection period for each host. All data was collected between July 1995 and March 1996.

Volume Type	Number
User	63
System	37
Project	64
Test	17
Total	181

Table 7.8: Volume Classification

This table shows the number of volumes of each type represented in the *mond* data. User volumes store private data. System volumes contain released software, such as binaries and libraries. Project volumes hold data used in collaborative work, such as system source areas. Test volumes are used by Coda developers for system testing and demonstration purposes.

7.4.2 Use in Practice

There are two ways in which a Coda client in actual use may find conditions less than ideal. First, a client may not possess volume stamps for some objects at disconnection. If frequent, this event would indicate that the strategy of waiting for a hoard walk to acquire volume callbacks is not aggressive enough. Second, a volume stamp may prove to be stale when presented for validation. This would mean that the volume was updated on the server while the client was disconnected. If frequent, this event would indicate that acquiring volume stamps is futile, because it rarely speeds up validation. It could also be symptomatic of a volume being too large a granularity for cache coherence, for reasons analogous to false sharing in virtual memory systems with too large a page size. This section answers the following questions:

- How often do volume validations succeed?
- How often do clients miss opportunities to validate their caches by volume?
- How often are volume callbacks broken?
- To what extent are volume callback breaks and failed validations due to false sharing?

7.4.2.1 Measurement Framework

Coda clients were instrumented to record statistics on volume callback usage, and the data was collected using the *mond* measurement framework [91]. Clients collect, summarize, and buffer data in RVM, and then periodically ship it to a central data collector. The collector writes the data to a disk log. Later, a reaper process reads the data from the log and inserts it into a relational database. Once in the database, the data may be analyzed off-line using queries.

Client	Missing Stamp	Validation Attempts	Fraction Successful	Objs per Success
bach	1%	19468	98%	146
berlioz	2%	24962	98%	93
brahms	2%	8963	98%	57
chopin	8%	18920	98%	117
copland	2%	19648	97%	99
dvorak	4%	12703	97%	92
gershwin	28%	1994	95%	35
gs125	0%	927	99%	22
handel	3%	7923	97%	57
holst	1%	4841	98%	55
ives	3%	21563	98%	57
mahler	2%	11238	97%	32
messiaen	1%	12786	99%	55
michaelangelo	0%	3383	98%	146
mootaz	1%	4963	98%	283
mozart	2%	20091	98%	80
purcell	9%	18272	99%	71
schumann	6%	239	94%	25
varicose	2%	7572	97%	45
verdi	22%	8808	98%	42
vivaldi	4%	324	92%	28
Mean	5%	10933	97%	78

Table 7.9: Observed Volume Validation Statistics - Desktops

This table presents data collected from July 1995 to March 1996 from 21 desktops. The “Missing Stamp” column indicates how often validation could not be attempted because of a missing volume stamp. The “Objs per Success” column gives a per-client average of the number object validations saved by each successful volume validation.

Client	Missing Stamp	Validation Attempts	Fraction Successful	Objs per Success
caractacus	1%	1768	95%	162
deidamia	2%	5012	97%	110
elijah	0%	439	98%	8
eroica	3%	2967	96%	66
finlandia	27%	3939	97%	42
genoveva	5%	817	98%	38
giselle	1%	265	95%	79
gloriana	2%	4223	98%	44
guntram	10%	4928	99%	108
harawi	1%	1486	97%	63
hiawatha	3%	15636	98%	112
jupiter	1%	4912	97%	31
messiah	9%	2726	98%	77
nabucco	1%	4251	97%	25
oberon	3%	3594	98%	51
phoenix	2%	1977	97%	174
planets	5%	976	95%	35
porgy	11%	2203	97%	70
prometheus	3%	12371	97%	62
serse	2%	4604	98%	21
spartacus	2%	2837	97%	35
tosca	2%	2697	97%	47
valkyrie	6%	5253	92%	63
Mean	4%	4080	97%	66

Table 7.10: Observed Volume Validation Statistics - Notebooks

This table presents data collected from July 1995 to March 1996 from 23 notebooks. Table headings are as in Table 7.9.

Clients recorded summary statistics each time a volume version stamp was acquired or validated, each time a stamp would have been validated if one had been present, and each time a volume callback was broken or cleared (because of connectivity changes). Data was collected from 44 clients (21 desktops and 23 notebooks) from July 1995 to March 1996. Collection intervals varied between machines for two reasons. First, a number of clients, particularly notebooks, were deployed during the collection period. Second, data collection was suspended during the period because of two month-long outages at the central data collector. Because clients buffer summary statistics in RVM, most were able to cover the failure completely once data collection resumed. However, if a Venus was reinitialized on a client during the suspension, some data was lost. Table 7.7 shows the number of days of data accumulated from each machine. The data covered a total of 181 volumes, classified by type in Table 7.8.

7.4.2.2 Results

Validation Statistics Tables 7.9 and 7.10 present validation statistics from all clients. The data shows that the average success rate for volume validations was 97%, and each successful volume validation saved an average of 70 file validations. There was no significant difference in the success rate between desktops and notebooks. On average, clients attempted 62 validations per day. The number of validation attempts is determined by the number of volumes represented in the cache, and the number of connectivity changes observed in the AVSGs for those volumes. (Recall that validation is necessary when the AVSG grows, because a newly available server may hold new data.) The rate of connectivity changes in our environment is high for two reasons. First, the servers are restarted automatically once a day, and the time to restart exceeds client probe intervals. Second, the Ethernet backbone is heavily used and is subject to transient failures. Desktop machines had a higher rate of validations attempted than notebooks (67 compared to 53). Although notebooks observed a slightly higher rate of connectivity changes, desktops had a higher number of volumes represented in the cache on average.

The data also shows that, on average, clients found themselves without a volume stamp only in 5% of the cases. This small number indicates that the policy of acquiring stamps on hoard walks is aggressive enough. Four clients were missing version stamps more than 10% of the time, and three clients were missing stamps more than 20% of the time. In the past, such rates were typical for clients whose periodic hoard walks had been deliberately turned off. If hoard walks are off, Venus does not obtain new volume version stamps, and it loses the ones it has as volume callbacks are broken and volume validations fail. The two notebook clients, *porgy* and *finlandia*, used this feature. The desktop clients, *gershwin* and *verdi*, were being used as compilation engines during the period in which the rate of missing stamps was high. For these clients, it is unclear if it was callback breaks or the absence of hoard walks that caused the high missing stamp rates.

Volume Type	Number of Breaks		% Broken	
	Median	Range	Median	Range
User	8	0–29381	2	0–85
System	19	0–825	1	0–29
Project	0	0–5800	0	0–27
Test	13	0–908	26	0–87
All	4	0–29381	1	0–87

Table 7.11: Incidence of Volume Callback Breaks

This table shows the number of volume callbacks broken for all clients in Table 7.7, and the percentage of all volume callbacks established (through acquisition or validation of a volume version stamp) that are broken. Data is presented by volume type. The median and range are given because the distributions are skewed towards zero.

Volume Type	Number of Losses		% False	
	Median	Range	Median	Range
User	10	0–29828	3	0–82
System	41	0–863	1	0–91
Project	2	0–6301	1	0–24
Test	10	0–1031	17	0–83
All	7	0–29828	1	0–91

Table 7.12: Incidence of False Sharing

This table shows the number of lost volume callbacks and failed volume validations for all clients in Table 7.7, and the percentage of all volume callbacks established (through acquisition or validation of a volume version stamp) that are subsequently lost because of false sharing. Data is presented by volume type. The raw data differs from Table 7.11 because it includes failed validations. The distributions of the number and percentage of losses (not shown) are skewed towards zero.

Volume Callback Breaks A volume callback is insurance for disconnection – if the unfortunate happens, one at least has a rapid way of recovering. The price of this insurance has two components. One component, the cost of acquiring volume callbacks, is small because acquisition is piggybacked on hoard walks. The second component is the cost of handling volume callback breaks. Although a single break is cheap, frequent breaks may add up to a nontrivial cost.

Data on the incidence of volume callback breaks for the entire collection period is presented in Table 7.11. The table shows that both the median number and percentage of callbacks broken is low overall. The overhead due to volume callback breaks is limited by hoard walk frequency, because volume callbacks are acquired only during hoard walks.

The data overstates the number of volume callback breaks for volumes stored on the beta servers. Occasionally, bugs in server software can corrupt recoverable virtual memory to such an extent that the server must be reinitialized. In the past, replicated volumes on the newly reinitialized servers were repopulated using the resolution subsystem; the server received its files from other AVSG members as clients referenced them. Because resolution updates version vectors, to clients it appeared that every file stored in every VSG containing the reinitialized server was updated. All connected clients lost their volume and file callbacks, and all disconnected clients' volume and file validations failed upon reconnection. One of the beta servers was reinitialized three times during the data collection period; subsequent resolutions affected 19 system volumes, 47 project volumes, and 18 user volumes. This phenomenon no longer occurs, because Coda now uses a new re-initialization procedure that allows (good) recoverable state to be preserved and reloaded.

The volumes whose callbacks were broken most frequently were user volumes, and in particular, those of the most active Coda developers. Their volumes are both frequently updated and widely shared among clients. Anecdotal evidence suggests that some of these callback breaks arise from a user updating an object on her desktop, thus invalidating the cached copy on her connected notebook.

System volumes accounted for the largest median number of callbacks broken, but the smallest range. They are widely shared, but updated infrequently. The system volume that had both the highest number and percentage of callbacks broken was stored on the beta servers, and contained a version of the Lucid Emacs editor that was used by a few project members. The volume was updated several times in late 1995 and early 1996 independent of resolution. A single notebook client accounted for most of the broken callbacks. Although the data does not contain detailed timing information, it is possible that the client repeatedly obtained and lost callbacks on this volume because its files were undergoing resolution. Excluding this volume does not change the medians given in Table 7.11, but changes the ranges for system volumes to 0–650 callbacks broken and 0–15% of callbacks broken.

Since project volumes are used for collaborative work, one would expect to see a good deal

of callback activity. But the low number of callback breaks indicates that the actual amount of collaboration is low. Although these volumes are shared widely, they change relatively slowly. The reason for the slow rate of change is that users of source files make private copies for development, and modify the shared areas only when they are ready to release final versions of their changes. The most active project volume by far, both in number and percentage of callbacks broken, was the volume containing the alpha release of the Coda sources. Although this volume is updated only occasionally (an earlier set of data showed that it was completely unchanged for over half the days in a three month period [84]) nearly every client caches files from it and obtains volume callbacks on it. Therefore, an update in this volume generates many volume callbacks. Excluding this volume does not change the medians given in Table 7.11, but changes the ranges for project volumes to 0–1717 callbacks broken and 0–15% of callbacks broken.

Test volumes showed the highest percentage of callbacks broken, both in median and range. However, the number of callbacks broken was low, and activity in these volumes is by nature contrived. Results for test volumes are shown only to separate them from other volume classes.

False Sharing Recall from Section 4.2.2 that when a client updates an object in a volume, all other clients caching the volume version stamp will lose the stamp through either a volume callback or a failed volume validation. If the client caches do not contain the object that was updated, *false sharing* has occurred on the volume. Since both the number and percentage of failed validations and volume callback breaks is low overall (Tables 7.9-7.11) the impact of false sharing on the system is minimal.

Table 7.12 shows the number of losses of volume version stamps over the collection period, from both volume callback breaks and failed validations, and the percentage of losses caused by false sharing. The data overstates the number of losses because of resolution activity after server reinitialization. This activity is responsible for some of the false sharing, however, it is not possible to separate this activity from the data.

User volumes exhibited the largest range of lost version stamps due to false sharing. This sharing arises from several sources. First, as mentioned earlier, users share files between their desktop and notebook clients. Second, users cache files from other user volumes. If the number of files cached from other user volumes is small, as is the case for the hoard profiles shown in Table 7.3, remote updates are likely to produce false sharing at the volume level. Third, user object volumes are shared among clients of different architectures. When users compile software, the compilation engines update files in the same volume, even though they operate on separate parts of the name space. User object volumes had a higher median proportion of false sharing (24%, with a range of 0-50%) than user volumes in general.

Project volumes show the lowest proportion of lost version stamps due to false sharing. The Coda source and documentation areas experienced the most false sharing. This is not

surprising, because project members tend to work on independent modules within the system.

System volumes had the widest range of losses by percentage, however, the number of losses overall was small. The volume with the highest number of losses was the Emacs volume mentioned earlier in the discussion on volume callback breaks. The two volumes with the highest proportion of false sharing were not widely used; collectively clients obtained less than 50 volume callbacks on these volumes during the entire collection period. Excluding these volumes narrows the range of false sharing by proportion to 0-12%.

7.5 Trickle Reintegration

How much is a typical user's activity slowed when weakly connected? This is the question most germane to trickle reintegration, because the answer will reveal how effectively foreground activity is insulated from update propagation over slow networks.

The simplest way to answer this question would be to run a standard file system benchmark on a write-disconnected client over a wide range of network speeds. The obvious candidate is the Andrew benchmark [49] because it is compact, portable, and widely used. Unfortunately, this benchmark is of limited value in evaluating trickle reintegration. First, the running time of the benchmark on current hardware is very small, typically less than three minutes. This implies that no updates would be propagated to the server during an entire run of the benchmark for any reasonable aging window. Increasing the total time by using multiple iterations is not satisfactory because the benchmark is not idempotent. Second, although the benchmark captures many aspects of typical user activity, it does not exhibit overwrite cancellations. Hence, its file references are only marginally affected by log optimizations. Third, the benchmark involves no user think time, which may be atypical of interactive applications.

The ultimate in realism would be to measure trickle reintegration in actual use by mobile users. But this approach has serious shortcomings. First, a human subject cannot be made to repeat her behavior precisely enough for multiple runs of an experiment. Second, many confounding factors make timing results from actual use difficult to interpret. Third, such experiments cannot be replicated at other sites or in the future.

To overcome the limitations of these approaches, the evaluation of trickle reintegration is based on *trace replay*, in which a workload from a file reference trace is replayed on the system under evaluation. Since a trace replay reflects the activity of a real workload, the results are likely to be a much better indicator of performance of the system in actual use. The use of trace replay is an original contribution of this work.

7.5.1 Methodology: Trace Replay

The evaluation of trickle reintegration is based on an experimental methodology in which operations in a file reference trace are replayed at the client. Realism is preserved since the trace was generated in actual use. Timing measurements are much less ambiguous than with human subjects, since experimental control and replicability are easier to achieve. In addition, the traces and the replay software can be exported. Note that a trace replay experiment differs from a trace-driven simulation in that traces are replayed on a live system. The replay software [86] generates UNIX system calls that are serviced by Venus and the servers just as if they had been generated by a human user. The only difference is that a single process performs the replay, whereas the trace may have been generated by multiple processes. It would be fairly simple to extend the replay software to exactly emulate the original process structure.

Since a trace is often used many months or years after it was collected, the system on which it is replayed may be much faster than the original. But a faster system will not speed up those delays in the trace that were caused by human think time. Unfortunately, it is difficult to reliably distinguish think time delays from system-limited delays in a trace. However, large delays are more likely to be caused by user think time than system limits.

To incorporate the effect of human think time, the evaluation includes a sensitivity analysis for think time, using a parameter called *think threshold*, λ . This parameter defines the smallest delay in the input trace that will be preserved in the replay. When λ is 0, all delays in the trace are preserved; when it is infinity, the trace is replayed as fast as possible. Neither of these extreme values is used for the experiments. At $\lambda = 0$, there is so much opportunity for overlapping data transmission with think time that experiments would be biased too much in favor of trickle reintegration. At $\lambda = \infty$, the absence of think time makes the experiment as short as the Andrew benchmark. In the light of these considerations, the experiments use values of λ equal to 1 second and 10 seconds. These are plausible values for typical think times during periods of high activity, and they are not biased too far against or in favor of trickle reintegration.

Since log optimizations play such a critical role in trickle reintegration, the evaluation includes a sensitivity analysis for this factor as well. The traces described in Section 5.4 were divided into 45-minute segments, and the segments with the highest activity levels were analyzed for their susceptibility to log optimizations. (Segments longer than 45 minutes would have made the duration of each experiment excessive, allowing only a few parameter combinations to be explored.) The *compressibility* of a trace segment is defined as the ratio of two quantities obtained when the segment is run through the Venus simulator, described in Section 5.4.2. The numerator is the amount of data optimized out; the denominator is the length of the unoptimized CML. Figure 7.13 shows the observed distribution of compressibility in those trace segments with a final CML of 1 MB or greater. The data shows that the compressibilities of roughly a third of the segments are below 20%, while those of the remaining two-thirds

range from 40% to 100%. One segment from each quartile of compressibility was used for the experiments. The characteristics of these segments are shown in Figure 7.14.

There are 64 combinations of experimental parameters: four workloads, each a trace segment representing one quartile of compressibility (8, 32, 69, and 94%); two reasonable aging windows ($A = 300$ and 600 seconds), including the system default; two think thresholds ($\lambda = 1$ and 10 seconds); and four network types, Ethernet (10 Mb/s), Wavelan (2 Mb/s), ISDN (64 Kb/s), and Modem (9.6 Kb/s). Except for ISDN, experiments were performed on actual networks of the corresponding type, using the configurations depicted in Figure 7.1. The ISDN experiments were conducted on an Ethernet using the network emulator described in Section 7.4.1.1.

The experiments were run in a single volume on a single server. Venus was forced to remain write disconnected at all bandwidths. All measurements were deferred until 600 seconds into each run, thus warming the CML for trickle reintegration. The choice of 600 seconds corresponds to the largest value of A used in the experiments.

7.5.2 Results

Elapsed Time Tables 7.15 – 7.21 presents the elapsed times of the trace replay experiments. The same data is graphically illustrated in Figures 7.16 – 7.22. These measurements confirm the effectiveness of trickle reintegration over the entire experimental range. Bandwidth varies over three orders of magnitude, yet elapsed time remains almost unchanged. On average, performance is only about 2% slower at 9.6 Kb/s than at 10 Mb/s. Even the worst case, corresponding to the Ethernet and ISDN numbers for Concord in Figure 7.22, is only 11% slower.

What effects do the experimental parameters have on Venus' execution of the workloads? The aging window is a factor for compressible workloads. A small aging window gives Venus little time to optimize records from the CML, and therefore more data to send to the server. The more time Venus spends reintegrating data, the greater the likelihood of file contention. File contention can cause delays in forward processing because Venus must make a shadow copy of the cache container file. A large aging window, on the other hand, allows Venus to take greater advantage of CML optimizations on compressible trace segments. Since CML records are stored in RVM, optimizations create more RVM activity. This activity causes Venus to invoke RVM log flush and truncation operations more frequently, and these operations can cause substantial delays in concurrent request processing.

Factors other than the aging window can influence the amount of CML optimization for compressible workloads. The think threshold controls the amount of delay between operations. Different think thresholds result in different benchmarks; it is not meaningful to compare elapsed times between experiments where this parameter differs. A lower think threshold

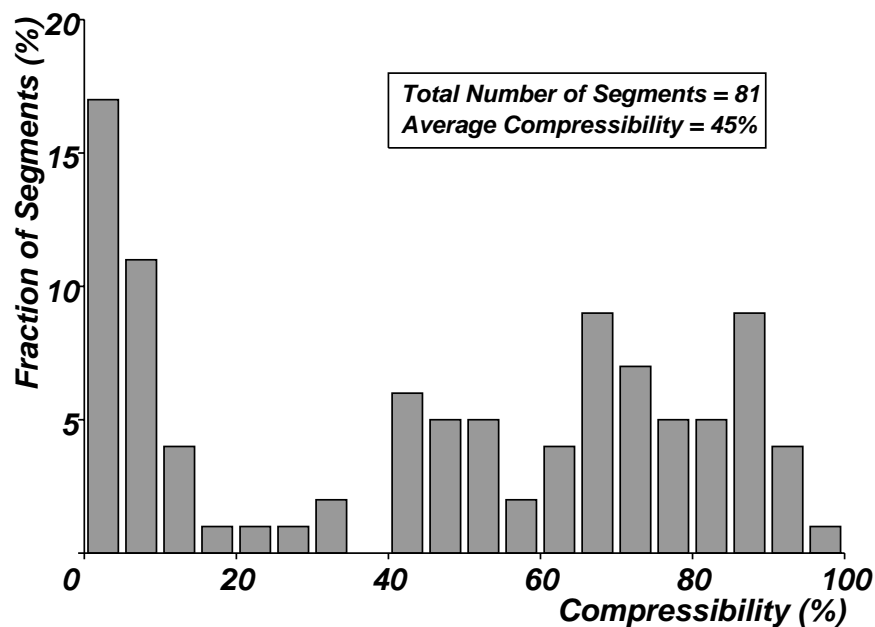

Figure 7.13: Compressibility of Trace Segments

This figure shows the compressibility of 45 minute trace segments with final CML sizes of 1 MB or greater. The compressibility is defined as the ratio of the amount of CML optimizations to the length of the unoptimized CML when the segment is run through the Venus simulator.

Trace Segment	No. of References	No. of Updates	Unopt. CML (KB)	Opt. CML (KB)	Compressibility
Purcell	51681	519	2864	2625	8%
Holst	61019	596	3402	2302	32%
Messiaen	38342	188	6996	2184	69%
Concord	160397	1273	34704	2247	94%

Table 7.14: Segments Used in Trace Replay Experiments

Each of these segments is 45 minutes long. Since Coda uses the open-close session semantics of AFS, individual read and write operations are not included. Hence "Updates" in this table only refers to operations such as close after writing, and mkdir. "References" includes, in addition, operations such as close after reading, stat, and lookup.

Trace Segment	Ethernet 10Mb/s	Wavelan 2Mb/s	ISDN 64 Kb/s	Modem 9.6 Kb/s
Purcell	2025 (16)	1999 (15)	2002 (20)	2096 (32)
Holst	1960 (3)	1961 (5)	1964 (5)	1983 (5)
Messiaen	1950 (2)	1970 (9)	1959 (3)	1995 (6)
Concord	1897 (9)	1952 (20)	1954 (43)	2002 (13)

Table 7.15: Performance of Trace Replay ($\lambda = 1$ second, $A = 300$ seconds)

This table presents the elapsed time, in seconds, of the trace replay experiments described in Section 7.5.1. The think threshold, λ , is 1 second, and the aging window, A , is 300 seconds. Each data point is the mean of five trials; figures in parentheses are standard deviations. Measurements began after a 10 minute warming period.

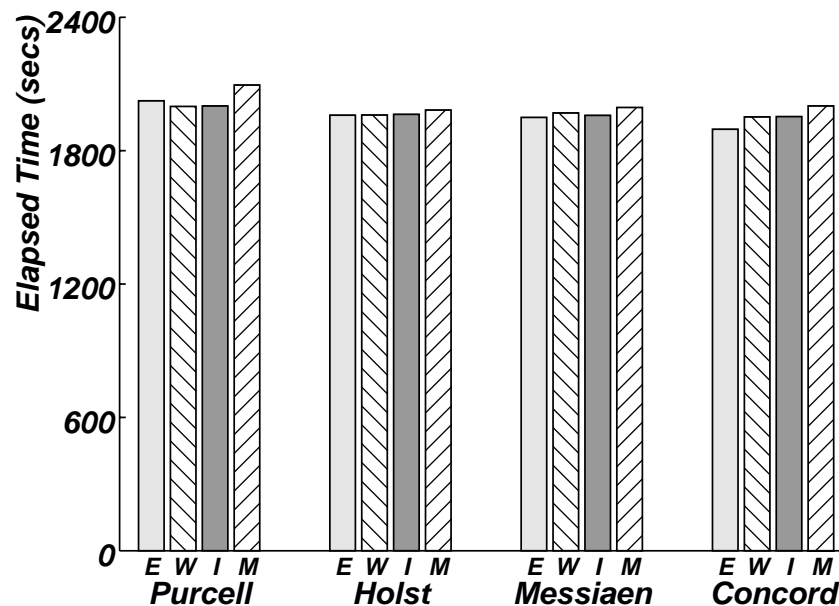

Figure 7.16: Performance of Trace Replay ($\lambda = 1$ second, $A = 300$ seconds)

This graph illustrates the data in Table 7.15. Network speed is indicated by **E** (Ethernet), **W** (WaveLan), **I** (ISDN), or **M** (Modem).

Trace Segment	Ethernet 10Mb/s	Wavelan 2Mb/s	ISDN 64 Kb/s	Modem 9.6 Kb/s
Purcell	2086 (28)	2064 (6)	2026 (20)	2031 (4)
Holst	2004 (13)	1984 (11)	1970 (11)	2009 (17)
Messiaen	1949 (2)	1974 (8)	1969 (16)	1986 (3)
Concord	2078 (49)	2051 (38)	2017 (39)	2079 (10)

Table 7.17: Performance of Trace Replay ($\lambda = 1$ second, $A = 600$ seconds)

This table presents the elapsed time, in seconds, of the trace replay experiments for $\lambda = 1$ second and $A = 600$ seconds.

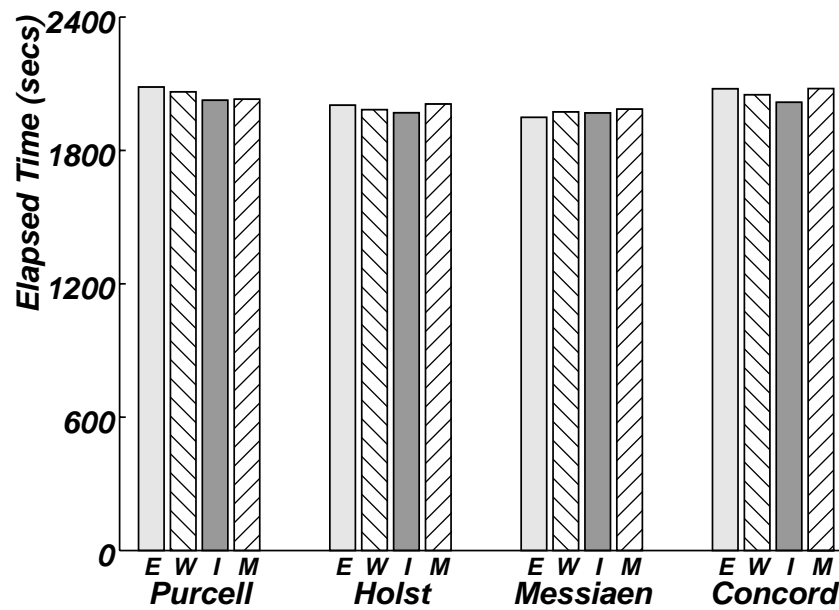

Figure 7.18: Performance of Trace Replay ($\lambda = 1$ second, $A = 600$ seconds)

This graph illustrates the data in Table 7.17.

Trace Segment	Ethernet 10Mb/s	Wavelan 2Mb/s	ISDN 64 Kb/s	Modem 9.6 Kb/s
Purcell	1747 (20)	1622 (12)	1624 (5)	1744 (8)
Holst	1026 (6)	1000 (3)	1005 (10)	1047 (2)
Messiaen	1234 (2)	1241 (2)	1238 (5)	1278 (9)
Concord	1254 (7)	1323 (16)	1312 (17)	1362 (18)

Table 7.19: Performance of Trace Replay ($\lambda = 10$ seconds, $A = 300$ seconds)

This table presents the elapsed time, in seconds, of the trace replay experiments for $\lambda = 10$ second and $A = 300$ seconds.

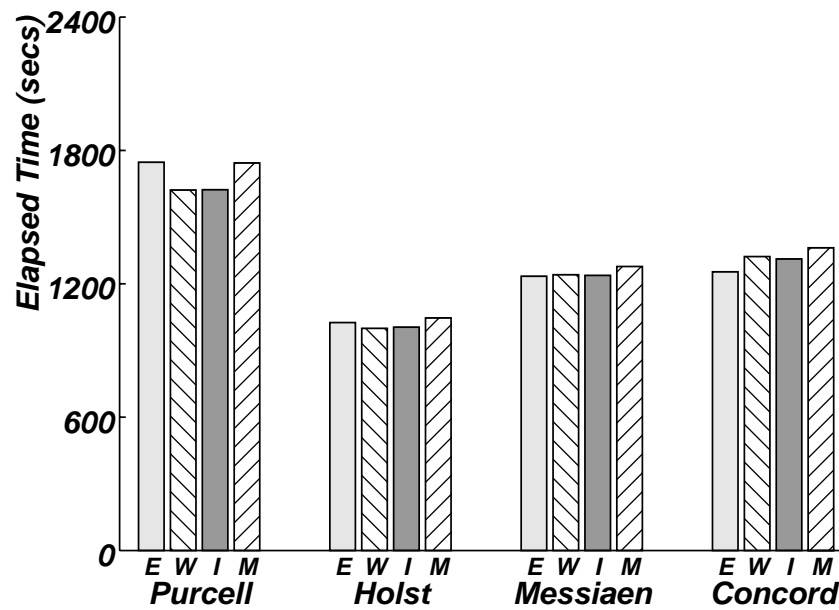
Figure 7.20: Performance of Trace Replay ($\lambda = 10$ seconds, $A = 300$ seconds)

This graph illustrates the data in Figure 7.19.

Trace Segment	Ethernet 10Mb/s	Wavelan 2Mb/s	ISDN 64 Kb/s	Modem 9.6 Kb/s
Purcell	1704 (9)	1658 (14)	1664 (23)	1683 (16)
Holst	1060 (10)	1027 (8)	1021 (8)	998 (3)
Messiaen	1234 (3)	1265 (13)	1263 (11)	1279 (7)
Concord	1258 (7)	1383 (27)	1402 (30)	1340 (16)

Table 7.21: Performance of Trace Replay ($\lambda = 10$ seconds, $A = 600$ seconds)

This table presents the elapsed time, in seconds, of the trace replay experiments for $\lambda = 10$ second and $A = 600$ seconds.

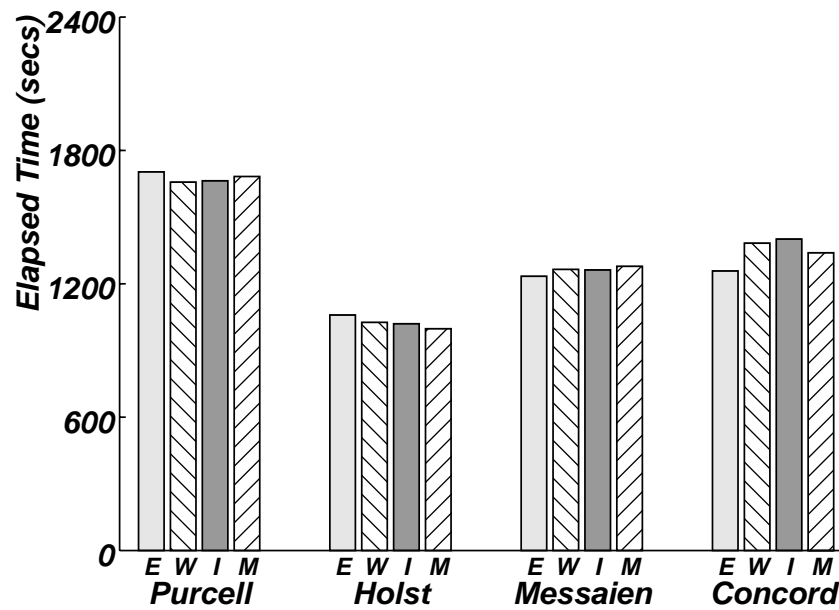

Figure 7.22: Performance of Trace Replay ($\lambda = 10$ seconds, $A = 600$ seconds)

This graph illustrates the data in Figure 7.21.

Trace Segment	λ	A	Network Bandwidth	File Contention Overhead	
				(secs)	%
Messiaen	1	300	64 Kb/s	1	< 0.1
Concord	1	300	64 Kb/s	15	0.7
Concord	1	300	9.6 Kb/s	15	0.8
Concord	1	600	64 Kb/s	9	0.4
Concord	1	600	9.6 Kb/s	18	0.9
Concord	10	300	64 Kb/s	4	0.3
Concord	10	600	64 Kb/s	7	0.5

Table 7.23: Residual Effect of File Contention

This table shows the effect of file contention on the results in Tables 7.15 - 7.21. Only the experiments shown above were affected. The overhead is expressed as the mean number of seconds of the elapsed time due to file contention, and the percentage increase in elapsed time over the experiment without file contention.

means operations are spaced more widely in time. For updates, a lower think threshold has an effect similar to a small aging window – the smaller the think threshold, the lower the likelihood that optimizing updates fall within a given aging window.

Network bandwidth determines how much CML data is shipped to the server. At low bandwidth, it is network throughput rather than the aging window that determines how long records stay in the CML. Therefore, low bandwidth can serve to increase opportunities for CML optimizations in compressible workloads. At high bandwidth, Venus is able to reintegrate more of the CML during the benchmark. Commitment of CML records upon successful reintegration also generates RVM activity. For experiments that are otherwise equivalent, the runs at higher bandwidth may have a longer elapsed time because of RVM activity generated from committing log records. For example, there were more truncations over Ethernet than ISDN during Purcell workload at $A = 300$ and $\lambda = 10$, and truncation times over Ethernet were two to three times longer.

During trickle reintegration, the container files associated with `store` records are locked to ensure that a consistent copy of the data is propagated to the server. The initial implementation of trickle reintegration blocked updates to the file until reintegration completed. Evaluation

of this implementation revealed that file contention was a serious problem. The contention occurred more often at the smaller aging window; the larger window allowed the overwrite to cancel the store record before Venus attempted to reintegrate it. Not surprisingly, it was most severe at the lowest bandwidth. The fix for this problem is to create a shadow copy of the object when contention occurs, as described in Section 5.3.1.2. File contention occurred during seven of the 64 trace replay experiments. Table 7.23 shows the residual overhead of file contention on the affected experiments using shadowing. The overhead is primarily due to copying the cache file. The results show that the effect of file contention using shadowing is miniscule, accounting for less than 1% of the elapsed time in all experiments in which it occurred.

There are many sources of variability within experiments. The main sources are the periodic daemons within Venus that perform various housekeeping tasks, and in particular, the daemon that performs RVM log truncation. This daemon alone accounts for differences in elapsed times in the tens of seconds. Trickle reintegration is triggered by one of the periodic daemons; in compressible workloads, minor differences in scheduling can determine whether or not file contention occurs, or a CML record is optimized. File contention did not have a large effect on the results, but did occur during the two most compressible workloads (Messiaen and Concord).

Data Shipped Trickle reintegration achieves insulation from network bandwidth by decoupling updates from their propagation to servers. Tables 7.24 – 7.27 illustrate this decoupling for all combinations of λ and A . The tables show, for each segment, the amount of data in the CML at the beginning and end of the measurement period, as well as the amount of data shipped to servers and optimized from the CML.

It may appear at first glance that the sum of the "End CML", "Shipped", and "Optimized" columns should equal the "Unopt. CML" column of Figure 7.14. But this need not be true for a number of reasons. First, because the measurement period begins 10 minutes into each workload, Venus may perform CML optimizations or reintegrate during the warming period. This activity is not included in the tables. For example, in Table 7.24(b), Venus reintegrated approximately 2 MB of CML data during the warming period over Ethernet and Wavelan. But over the slower ISDN and Modem connections, the data was still in the CML at the end of the warming period. Second, if an experiment ends while a large file is being transferred as a series of fragments, the fragments already transferred are counted both in the "End CML" and "Shipped" columns. That is, a `store` record is not removed from the CML until all of its fragments are shipped to the server. In some cases, the number of fragments shipped by the end of an experiment varies by run, resulting in non-zero variance for the amount of data shipped even if all other figures have zero variance. Such is the case, for example, for the ISDN and Modem experiments of Table 7.26(a). Third, the packed representation of CML records when shipped to the servers is larger than in the CML itself.

In general, as bandwidth decreases, so does the amount of data shipped. For example, in Table 7.25(b), the data shipped decreases from 2254 KB for Ethernet to 1536 KB for Modem.

Network Type	Begin CML (KB)		End CML (KB)		Shipped (KB)		Optimized (KB)	
Ethernet	0	(0)	49	(0)	2603	(3)	189	(0)
WaveLan	0	(0)	49	(0)	2679	(0)	189	(0)
ISDN	0	(0)	523	(0)	2388	(0)	238	(0)
Modem	0	(0)	2351	(82)	383	(35)	238	(0)

(a) Trace Segment = Purcell

Network Type	Begin CML (KB)		End CML (KB)		Shipped (KB)		Optimized (KB)	
Ethernet	0	(0)	54	(0)	127	(0)	1068	(0)
WaveLan	1	(0)	54	(0)	135	(0)	1067	(0)
ISDN	2119	(0)	54	(0)	1409	(128)	1068	(0)
Modem	2119	(0)	2289	(0)	1666	(53)	1082	(0)

(b) Trace Segment = Holst

Network Type	Begin CML (KB)		End CML (KB)		Shipped (KB)		Optimized (KB)	
Ethernet	0	(0)	0	(0)	1469	(0)	2927	(0)
WaveLan	0	(0)	0	(0)	1412	(52)	2984	(52)
ISDN	0	(0)	0	(0)	1431	(52)	2965	(52)
Modem	708	(0)	957	(229)	1439	(55)	3022	(0)

(c) Trace Segment = Messiaen

Network Type	Begin CML (KB)		End CML (KB)		Shipped (KB)		Optimized (KB)	
Ethernet	63	(0)	2105	(0)	4602	(1)	28107	(1)
WaveLan	63	(0)	2105	(0)	4604	(4)	28106	(2)
ISDN	63	(0)	4073	(0)	2885	(33)	28092	(31)
Modem	63	(0)	2180	(0)	1345	(58)	32260	(0)

(d) Trace Segment = Concord

Table 7.24: Data Generated During Trace Replay ($\lambda = 1$ second, $A = 300$ seconds)

This table shows components of the data generated in the experiments of Figure 7.16. Each entry is the mean of five trials; figures in parentheses are standard deviations. Measurements began after a 10 minute warming period. The columns labelled "Begin CML" and "End CML" give the amount of data in the CML at the beginning and end of the measurement period. This corresponds to the amount of data waiting to be propagated to the servers at those times. The column labelled "Shipped" gives the amount of data actually transferred over the network; "Optimized" gives the amount of data saved by optimizations.

Network Type	Begin CML (KB)		End CML (KB)		Shipped (KB)		Optimized (KB)	
Ethernet	0	(0)	59	(0)	2618	(0)	238	(0)
WaveLan	0	(0)	59	(0)	2618	(0)	238	(0)
ISDN	0	(0)	2128	(0)	800	(105)	238	(0)
Modem	0	(0)	2538	(0)	114	(19)	238	(0)

(a) Trace Segment = Purcell

Network Type	Begin CML (KB)		End CML (KB)		Shipped (KB)		Optimized (KB)	
Ethernet	2133	(0)	70	(0)	2254	(0)	1067	(0)
WaveLan	2133	(0)	70	(0)	2254	(0)	1067	(0)
ISDN	2133	(0)	70	(0)	2252	(0)	1069	(0)
Modem	2133	(0)	2289	(0)	1536	(68)	1081	(0)

(b) Trace Segment = Holst

Network Type	Begin CML (KB)		End CML (KB)		Shipped (KB)		Optimized (KB)	
Ethernet	896	(0)	0	(0)	2270	(0)	3022	(0)
WaveLan	896	(0)	0	(0)	2270	(0)	3022	(0)
ISDN	896	(0)	0	(0)	2270	(0)	3022	(0)
Modem	896	(0)	1060	(0)	1309	(16)	3103	(0)

(c) Trace Segment = Messiaen

Network Type	Begin CML (KB)		End CML (KB)		Shipped (KB)		Optimized (KB)	
Ethernet	63	(0)	2103	(0)	2496	(0)	30209	(0)
WaveLan	63	(0)	2103	(0)	2496	(0)	30209	(0)
ISDN	63	(0)	2103	(0)	2407	(0)	30291	(0)
Modem	63	(0)	2180	(0)	1142	(46)	32322	(0)

(d) Trace Segment = Concord

Table 7.25: Data Generated During Trace Replay ($\lambda = 1$ second, $A = 600$ seconds)

This table shows components of the data generated in the experiments of Figure 7.18.

Network Type	Begin CML (KB)		End CML (KB)		Shipped (KB)		Optimized (KB)	
Ethernet	0	(0)	49	(0)	2679	(0)	189	(0)
WaveLan	0	(0)	49	(0)	2679	(0)	189	(0)
ISDN	0	(0)	1133	(0)	1528	(105)	238	(0)
Modem	0	(0)	2387	(0)	318	(46)	238	(0)

(a) Trace Segment = Purcell

Network Type	Begin CML (KB)		End CML (KB)		Shipped (KB)		Optimized (KB)	
Ethernet	99	(0)	70	(0)	114	(0)	1061	(0)
WaveLan	99	(0)	70	(0)	114	(0)	1061	(0)
ISDN	2218	(0)	70	(0)	1059	(2)	1064	(2)
Modem	2218	(0)	2289	(0)	858	(0)	1072	(0)

(b) Trace Segment = Holst

Network Type	Begin CML (KB)		End CML (KB)		Shipped (KB)		Optimized (KB)	
Ethernet	177	(0)	0	(0)	1734	(0)	3022	(0)
WaveLan	177	(0)	0	(0)	1374	(0)	3022	(0)
ISDN	177	(0)	0	(0)	1374	(0)	3022	(0)
Modem	901	(35)	1060	(0)	954	(18)	3104	(0)

(c) Trace Segment = Messiaen

Network Type	Begin CML (KB)		End CML (KB)		Shipped (KB)		Optimized (KB)	
Ethernet	164	(0)	2103	(0)	2496	(0)	30146	(0)
WaveLan	164	(0)	2103	(0)	2496	(0)	30146	(0)
ISDN	164	(0)	2103	(0)	2408	(0)	30227	(0)
Modem	164	(0)	2180	(0)	972	(47)	32196	(0)

(d) Trace Segment = Concord

Table 7.26: Data Generated During Trace Replay ($\lambda = 10$ seconds, $A = 300$ seconds)

This table shows components of the data generated in the experiments of Figure 7.20.

Network Type	Begin CML (KB)		End CML (KB)		Shipped (KB)		Optimized (KB)	
Ethernet	0	(0)	605	(11)	2066	(15)	238	(0)
WaveLan	0	(0)	1282	(777)	1373	(792)	238	(0)
ISDN	0	(0)	2431	(68)	207	(74)	238	(0)
Modem	0	(0)	2591	(0)	26	(0)	238	(0)

(a) Trace Segment = Purcell

Network Type	Begin CML (KB)		End CML (KB)		Shipped (KB)		Optimized (KB)	
Ethernet	2212	(44)	70	(0)	2249	(0)	1062	(0)
WaveLan	2232	(0)	70	(0)	2248	(3)	1063	(0)
ISDN	2232	(0)	70	(0)	2242	(4)	1067	(3)
Modem	2232	(0)	2289	(0)	712	(88)	1072	(148)

(b) Trace Segment = Holst

Network Type	Begin CML (KB)		End CML (KB)		Shipped (KB)		Optimized (KB)	
Ethernet	1073	(0)	1	(0)	2187	(0)	3104	(0)
WaveLan	1060	(28)	1	(0)	2187	(0)	3104	(0)
ISDN	1073	(0)	0	(0)	2187	(0)	3104	(0)
Modem	1073	(0)	1278	(0)	930	(19)	3103	(0)

(c) Trace Segment = Messiaen

Network Type	Begin CML (KB)		End CML (KB)		Shipped (KB)		Optimized (KB)	
Ethernet	164	(0)	2103	(0)	719	(906)	31908	(904)
WaveLan	164	(0)	2103	(0)	2345	(5)	30288	(4)
ISDN	164	(0)	2103	(0)	1552	(1081)	31080	(1080)
Modem	164	(0)	2103	(0)	296	(1)	32329	(1)

(d) Trace Segment = Concord

Table 7.27: Data Generated During Trace Replay ($\lambda = 10$ seconds, $A = 600$ seconds)

This table shows components of the data generated in the experiments of Figure 7.22.

There are a few exceptions. First, during the Holst workload with $A = 300$ (Tables 7.24(b) and 7.26(b)) Venus reintegrated data during the warming period. Second, during the Concord workload with $\lambda = 10$ and $A = 600$ (Table 7.27(d)), a large file was shipped in some runs, but not in others because the corresponding `store` record was optimized from the CML. This difference accounts for the large variance in the figures for data shipped and optimized in that table.

At the end of the experiment, more data remains in the CML at lower bandwidths. For example, in Table 7.25(b), the amount of data remaining in the CML is 70KB for Ethernet, versus 2289 KB for Modem. Many entries are non-zero even for Ethernet because updates occurred within an aging window (300 or 600 seconds) from the end of the workload.

CML optimizations increase as bandwidth decreases, because data spends more time in the CML. Using the Holst workload example of Table 7.25(b), the amount optimized for Ethernet is 1067 KB, compared to 1081 KB for Modem. Looking across experiments, as A increases so do CML optimizations. For example, optimizations increase for each network type during the Messiaen workload at $\lambda = 1$ as A increases from 300 to 600 seconds (Tables 7.24 and 7.25). Of course, highly compressible segments benefit more from the increased opportunity for optimization at lower bandwidths and larger aging windows.

7.6 Chapter Summary

This chapter has presented a quantitative evaluation of the transport protocol, rapid cache validation, and trickle reintegration mechanisms. The evaluation was performed in the Coda file system, and was based on controlled experimentation and empirical data gathered from the system in actual use. The evaluation showed that:

- performance of the transport layer is reasonable compared to the TCP implementation available under the operating system platform in use.
- rapid cache validation works well in practice; validation by volume is successful 97% of the time, and when successful, it compensates for a three order of magnitude reduction in network bandwidth.
- trickle reintegration successfully decouples client and network file system activity; elapsed time of a trace replay benchmark was nearly unchanged over the entire experimental range of network bandwidths.

Chapter 8

Related Work

The work described in this dissertation is unique in its focus on high level mechanisms for exploiting weak connectivity, and its identification of four key mechanisms through actual system use. Although some techniques resembling the mechanisms described have been used in other distributed systems, to the best of our knowledge, no other system has identified or combined these mechanisms in this way to provide support for weakly connected operation.

This chapter discusses work related to weak connectivity in distributed systems. The chapter is divided into two parts. The first part reports on systems and applications designed to cope with weak connectivity. The second part describes work related to the specific mechanisms used to support weak connectivity in Coda.

8.1 Systems that Exploit Weak Connectivity

Effective use of low bandwidth networks has been widely recognized as an important capability in mobile computing [40, 58]. But only a few systems currently provide this functionality. Of these, the Little Work distributed file system project [48, 50, 51] is most closely related to this work.

8.1.1 Distributed File Systems

8.1.1.1 Little Work

Like Coda, Little Work provides transparent UNIX file access to disconnected and weakly-connected clients. It is designed to be upward compatible with existing AFS servers, and thus makes no changes to the AFS client-server interface. This constraint hurts its ability to cope with

intermittent connectivity. First, it renders the use of rapid cache validation infeasible. Second, it weakens fault tolerance because the replay of client updates cannot use a transactional server primitive as in reintegration.

Little Work supports two flavors of weakly connected operation – *partially connected operation* and *fetch-only mode*. Partially connected operation is analogous to Coda’s write disconnected state. But there are important differences. First, users cannot influence the servicing of cache misses in Little Work. Second, update propagation is less adaptive than trickle reintegration in Coda. For example, there is no fragmentation mechanism to allow propagation of large files in a way that minimizes interference with other client activity. Third, much of Little Work’s efforts to reduce and prioritize network traffic occur in the SLIP driver. This is in contrast to Coda’s emphasis on the higher levels of the system. In fetch only mode, the client cache manager uses the network solely to satisfy cache misses. All cached files are assumed to be valid, and no cache coherence protocol is used. There is no analogue of this mode in Coda. It is unclear from the literature on Little Work if the transitions between the strongly connected, partially connected, and fetch only modes are performed automatically by the file system.

8.1.1.2 Ficus

Ficus is a distributed file system that supports optimistic replication [45, 46]. In Ficus, nodes are considered peers rather than clients and servers. Data is organized into volumes, which may be replicated across nodes. Updates may be performed as long as a single replica is available, and they are propagated to other replicas in a best-effort manner. A process called *reconciliation* runs periodically on behalf of each replica to pull over missed updates and detect conflicts.

Ficus is used over weak connections such as phone lines. A typical configuration includes workstations at home and at work, each hosting a replica of the user’s environment. The weak connection is used for reconciliation. The peer-to-peer structure of the system means that any two nodes hosting a volume replica may communicate and exchange data. Nodes do not cache data. Access to objects in volumes replicated at a node is efficient, because the data is local. However, if an object in a volume not hosted by the node is referenced, the node must access it remotely. Although nodes may be configured to minimize remote references, such references inevitably occur. Establishing a replica at a node is a heavyweight operation, and is a waste of resources if the files in that volume are rarely needed. Caching is lighter weight and more flexible than replica placement.

8.1.1.3 The Siphon

The Siphon system [102] was developed by DEC PRL to manage a shared software repository with objects replicated on both sides of a 56 Kb/sec transatlantic link. Repository units are

file system directories called *packages*, which are self-contained software or documentation collections. In this system reads are satisfied by a local replica which may be stale. Writes made to the local replica are propagated to the others as network bandwidth permits; propagation delays can range from a few minutes to a few hours. Writes are permitted only after a lock is acquired; a client cannot acquire a lock until the local replica is up-to-date. The repository described contained roughly 700 packages totalling 1.6 GB, of which about 40 MB propagated through the Siphon each day. The authors point out that availability was more of an issue in their system than bandwidth or latency. They claim a third to a half of the bandwidth would have been adequate for their purposes.

8.1.1.4 Commercial Products

There are a number of commercial products that keep files on a mobile host synchronized with servers or desktop machines. The one most similar to this work is Airsoft's AirAccess [2], which provides application-transparent support for disconnected and weakly connected file access. Its implementation focuses on the transport level, using techniques such as data compression and differential file transfer. Like Little Work, it preserves upward compatibility with existing servers and therefore suffers from the same limitations with respect to intermittent connectivity. It does not appear to have analogues to trickle reintegration and rapid cache validation, and the problem of servicing potentially lengthy cache misses over the weak link is not addressed.

Other file synchronization products, such as Microsoft's Briefcase [61, 124] and Traveling Software's LapLink [87], are non-transparent and require user intervention. In Briefcase, a user copies files that he wishes to access while mobile to a special part of the namespace called the briefcase, which may then be transferred to other devices. The system remembers the original location of the files. The user must manually invoke synchronization, and the system recommends reconciliation actions for objects in the briefcase (e.g., copy an updated version of a file from the briefcase to its original location). Newly created files and files with conflicting updates require user intervention. LapLink also provides tools for manual synchronization. Like AirAccess, it reduces data volume by transferring file differences rather than entire files.

8.1.2 Databases

There are a number of databases designed for use in weakly connected and disconnected environments. These systems use replicated, weakly consistent data. Replication improves availability when sites are disconnected from each other. Weak consistency is preferable to strong consistency because the latter would impose a severe penalty on availability and performance. Availability would be limited because read and update activity must be restricted during disconnections to avoid conflicts. Performance would suffer because distributed protocols must execute over slow and unreliable connections.

A use of weak connections in databases was proposed by Lilien [71]. In this work, weak connections are used as backup networks when a main network fails. The mode of operation when this occurs, called a *quasi-partition*, differs from both fully connected and partitioned operation. During quasi-partitions, activity within partitions is unrestricted, but message traffic is reduced between partitions. There are two primitive operations used during a quasi-partition: *creeping retrieval* and *creeping merge*, which provide for reads and update propagation over the weak link. In addition, the author lists several techniques helpful for reducing the volume of data sent over the link, such as compression, batching of requests and updates, and defining abbreviated messages. The system uses backup links to avoid making *a priori* preparations for true partitions. Coda does not avoid making preparations for true partitions; on the contrary it encourages it through hoarding.

More recent databases for use in weakly connected environments include Bayou [126], OSCAR [33], and Lotus Notes [59]. In Bayou, servers communicate in a pairwise fashion, propagating updates amongst each other in a process called *anti-entropy*. In OSCAR, agents for servers called *replicators* and *mediators* cooperate to distribute updates to as many replicas as possible. Lotus Notes is a commercial shared document database system that is used for group communication applications, such as document sharing, e-mail, and computer conferencing. Notes is intended for use in “rarely connected” environments, that is, environments in which workgroups do not enjoy continuously available high-speed network connectivity. A specific target of this system is workgroups communicating using PCs and dialup lines. The group communication applications supported by Notes have the following characteristics. Collaboration is accomplished by adding documents to a database. Once added, documents are not usually modified. Finally, collaborators do not need to see up-to-the-minute data at all times. These applications do not have strict consistency requirements, and can be supported by a weakly consistent replicated database. Notes uses optimistic replication among nodes that are peers. Updates are performed on the local replica; when nodes connect they pull new and changed documents from each other. The system guarantees eventual consistency, that is, changes made to one replica eventually migrate to all. The system detects and notifies users of conflicting updates.

These database systems differ from Coda in two important respects. First, they do not adapt dynamically to weak connections. They are structured in such a way that strong connections are not necessary, because applications access local replicas, and nodes communicate primarily to exchange updated data. Second, these systems are vertically integrated applications. In contrast, Coda can support any application written for the UNIX API.

8.1.3 Read Only Systems

Several read only systems have been implemented for use in wide area networks. The most notable of these systems is the World-Wide Web [9]. The Web is a wide area information system

structured to facilitate browsing. It consists of read only objects. Updates are issued by servers and propagated lazily to clients. The system provides no consistency guarantees. Network performance for Web accesses is frequently poor. Browsers such as Netscape Navigator cope with this by caching Web pages, providing user-selectable levels of consistency between cached and server copies, and hiding latency by overlapping image retrieval with user think time.

8.1.4 Application-Specific Approaches

From a broader perspective, some applications employ techniques to exploit low bandwidth networks. This approach differs from Coda in that support for mobility is entirely the responsibility of the application. By providing this support at the file system level, Coda obviates the need to modify individual applications. Further, by mediating the resource demands of concurrent applications, Coda can better manage resources such as network bandwidth and cache space.

8.1.4.1 Window Systems

Low Bandwidth X (LBX) [41] (now X.FAST [105]) is an example of application-specific exploitation of weak connectivity. LBX is a version of the X protocol which is more efficient over low bandwidth, high latency connections. It uses a special program to intercept X packets on either side of the network, and remove as much redundant information as possible. LBX makes more aggressive use of caching, re-encodes packets to require less space, uses changes with respect to previous packets (“deltas”) where appropriate, and compresses the result. To trade cost for performance, the amount of caching and specific compression algorithm used are negotiable. These strategies are intended for general use, not just in weakly connected environments.

8.1.4.2 Electronic Mail and News

There are a number of e-mail and data services designed to use weak connectivity, particularly in the form of wireless links. Examples include Eudora [103], Lotus cc:mail [80], RadioMail, and PINE [93]. These packages offer a range of features including automatic uploading and downloading of e-mail, wireless e-mail (e.g., to pagers), and data services such as news and weather reports.

Eudora and the Internet Message Access Protocol (IMAP4) [25], the protocol underlying PINE, contain features that help cope with weak connections. Eudora is a mail client based on the SMTP [101] and POP3 [78] protocols. It provides support for off-line composition of messages and automatic uploading and downloading of messages. It includes a “skip big

messages” option, which prevents downloading of large (> 40 Kbytes) messages. In this case, Eudora downloads the first few lines of the message and flags it to alert the user that it is a prefix.

IMAP4 allows a mail client to access and manipulate e-mail message folders, called *mailboxes*, at a server. IMAP4 supports includes disconnected message processing and synchronization upon reconnection, and online processing, in which the client manipulates remote messages directly [26]. In both cases, it is assumed that network connections are weak, and the protocol attempts to minimize network usage. Synchronization involves the processing of any queued commands at the client, and the updating of the client’s message cache with new server state [4]. In the latter step, the client fetches the current list of mailboxes, then for each mailbox the list of descriptors. The client determines the server’s state from the list of descriptors, and fetches new or updated messages from the server. Message synchronization is guided by the user in the form of configuration files that specify which mailboxes and messages to examine. IMAP provides three “online performance optimizations” to improve usability over weak connections [44]. First, a client can determine the message contents without fetching the entire message. For example, a message might have a few hundred bytes of text and several megabytes of image data. Second, the client can selectively fetch parts of messages. To continue the example, a client might elect to fetch only the text portion of a message. Finally, IMAP provides a mechanism for server-based searching and message selection to minimize data transfer.

8.1.4.3 Electronic Conferencing

The EDFM [32] system, developed at AT&T, combines design for manufacture (DFM) software for printed circuit boards with electronic conferencing software to allow simultaneous real-time viewing of circuit board designs among geographically separated development teams over a low bandwidth connection. Since circuit board designs involve many large engineering drawings with thousands of design objects, EDFM uses off-line preparation for an electronic conference to eliminate all but crucial communication for the real-time conference. A conference proceeds as follows. First a complete printed circuit board design is sent from a host to a remote sites off-line, prior to the conference. Both sites load this representation and begin the conference. Incremental design changes are transferred in real-time using a compact language for describing design elements. The changes, encoded in small messages, are then applied by the remote site.

8.2 Mechanisms for Weak Connectivity

Some of Coda’s mechanisms for weak connectivity a have been investigated in isolation in other systems. This section describes work similar to the individual Coda mechanisms for

exploiting weak connectivity.

8.2.1 Communications

The Coda communications layer offers adaptive transport protocols based on round trip time estimation, passive monitoring of network transmissions, and the export of measurements to adaptive applications through transmission logs. A number of transport protocols share some of these features. One of the most widely used adaptive transport protocols is TCP/IP [99]. Its round trip timing mechanism enables it to adapt to changing network conditions [52]. Its introduction of header compression has improved performance over low bandwidth connections [53]. Finally, it has been extended to operate over very high speed networks, and networks with large bandwidth delay products [54]. The TCP round trip timing and header compression mechanisms were applied to Rx, the AFS transport protocol, in the context of the Little Work project [5].

The QEX RPC protocol, an extension of the REX RPC protocol for ANSAware [3], also performs round trip timing [30]. In addition, QEX provides feedback to applications on the state of underlying communications, but in a different way than RPC2. QEX maintains QoS information on a per-session basis, and provides its feedback using a callback mechanism.

Applications that adapt their behavior based on estimates of network bandwidth and other parameters have been implemented primarily in the domain of multimedia. Strategies common in video applications include dropping frames and reducing picture quality when network performance degrades [24, 90].

8.2.2 Rapid Cache Validation

Independent of this work, the possibility of rapid cache validation has been recognized in the Ficus [46] and xFS [127] systems. Ficus uses a strategy called *time-based reconciliation* to reduce the amount of network traffic while detecting changes between two volume replicas. Each pair of volume replicas records the time that the last successful reconciliation started. Only those files that have changed more recently require checking. Another argument for maintaining cache coherence at a large granularity has been put forth independently by Wang and Anderson [127]. They propose maintaining cache coherence on clusters of files, such as subtrees. Their primary motivation is to reduce server state rather than communication. Neither Ficus nor xFS has reported on any quantitative evaluation of their mechanisms in the literature. Therefore, it is impossible to compare rapid cache validation in Coda with these systems.

The rapid cache validation approach for failure recovery contrasts with systems such as Autonet [106], which hide transients until the network appears stable using a system of *skeptics*. This approach makes sense if the cost of changing state is high – otherwise the system would

spend a disproportionate amount of time doing nothing but recovering from connectivity changes. If the the cost of recovery can be reduced, more slivers of connectivity can be exposed to the system and used. This is particularly important if there is monetary cost associated with the physical connection, or urgency in detecting the presence of new information.

8.2.3 Trickle Reintegration

Trickle reintegration bears resemblance to write-back caching, as used in distributed file systems such as Sprite [89], Echo [47, 74], and MFS [16]. As discussed in Section 5.1, both techniques reduce latency by deferring propagation of updates to servers, and reduce network bandwidth and server load by taking advantage of updates that cancel or overwrite each other. However, they differ in three respects. First, these systems preserve strict UNIX write-sharing semantics. They are able to do so because they all assume LAN connectivity. In weakly connected environments, this guarantee is impractical, because it would require strongly connected clients to wait for updates to propagate from weakly connected clients. Second, the primary focus of write-back caching is to reduce file system latency rather than data volume. In weakly connected environments, the emphasis is on reducing data volume. Third, write-back caching schemes maintain their caches in volatile memory, and thus suffer from the possibility of data loss due to system failures. Their need to bound the damage limits the delay before updates must be propagated. In contrast, the local persistence of updates in Coda allows for longer propagation delays, bounded only by concerns of client theft, loss or disk damage.

Chapter 9

Conclusion

Ubiquitous data access is an increasingly important capability for information systems. The demand for this capability is evident in the proliferation of portable computers and wireless communication. Network technology will remain diverse for the foreseeable future. Weak connectivity represents the lower end of the range of available technologies, and it is inevitable in mobile file access. Thus it is crucial that information systems cope with weak connectivity.

This dissertation has described several mechanisms necessary for coping with weak connectivity in a distributed file system. It has introduced adaptation to network conditions in multiple system layers. The foundation of adaptivity in this system is the communications layer, which derives and supplies information on network conditions to higher layers. The rapid cache validation mechanism enables the system to recover quickly in the face of intermittent connectivity. The trickle reintegration mechanism insulates the user from poor network performance by trading off consistency. The cache miss handling mechanism alerts the user to potentially lengthy service times and provides opportunities for intervention.

These mechanisms were implemented and deployed as part of the Coda file system, which enjoys daily use by several dozen users from mobile and stationary clients using Ethernet, WaveLAN, and SLIP connections. Measurements from the system show that it allows users to largely ignore the vagaries of network performance and reliability typical of mobile environments.

9.1 Contributions

The main contribution of this thesis is a demonstration that weak connectivity can be used effectively to alleviate the shortcomings of disconnected operation. More specifically, this thesis makes contributions in the following areas:

1. *Conceptual contributions*

- *Architectural focus on high level mechanisms for weak connectivity.*
Recognition of the importance of high level mechanisms results in substantial benefits for weakly connected operation. Low level improvements may enhance those mechanisms, but cannot replace them (Section 1.3).
- *Identification of mechanisms for weak connectivity.*
The mechanisms evolved through actual use of system, and were found to be necessary for weakly connected file access (Section 7.1).
- *First formal analysis of cache coherence in a distributed file system.*
The introduction of multiple granularities into the cache coherence protocol rendered it sufficiently complex that ad-hoc reasoning was no longer sufficient. A novel technique based on the notion of belief [18] was derived to reason about the correctness of the protocol (Appendix A).

2. *System design and implementation contributions*

- *Communications layer*
 - *Techniques for adaptation in user-level transport protocols.*
Incorporation of adaptation into RPC2 and SFTP protocols using round trip time estimation (Sections 3.2 and 3.3).
 - *Novel log-based technique for flexible, efficient export of network quality information.*
The transport protocols log measurements on network transmissions using a passive monitoring technique. Venus obtains these measurements through an API for exporting transmission logs, and derives bandwidth estimates to trigger transitions to and from weakly connected operation (Sections 3.4 and 3.5.2).
- *Rapid cache validation*
 - *Design and implementation of large granularity cache coherence protocol for rapid cache validation.*
Clients synchronize their caches with servers rapidly upon reconnection at the granularity of volumes. This mechanism improves system agility in intermittent environments (Chapter 4).
- *Trickle Reintegration*
 - *Design and implementation of adaptive, asynchronous update propagation mechanism.*
Clients propagate updates asynchronously to servers, in a manner that minimizes interference with demand activity (Chapter 5).

- *Use of aging as a metric for CML record propagation.*
Aging allows trickle reintegration to preserve the effectiveness of log optimizations by taking advantage of temporal locality of updates (Section 5.2.2).
- *Methodology for selecting aging windows and trace based analysis.*
A good default aging value for the window was chosen as a result of trace driven simulation and analysis of CML optimizations (Section 5.4).
- *Adaptive strategy for determining data propagation volume.*
The client uses bandwidth estimates to determine the amount of data to propagate at one time. If a record involves a large amount of new data, the data is transferred using high level fragmentation (Section 5.3.2).
- *Cache Miss Handling*
 - *Novel model-based technique for weakly-connected cache miss handling.*
This mechanism trades off impact of cache misses at low bandwidth between usability and performance degradation. (Chapter 6).

3. Evaluation contributions

- Controlled experiments showing transport protocol performance at least comparable to that of TCP (Section 7.3).
- Controlled experiments showing dramatic reduction in cache recovery times using rapid cache validation (Section 7.4.1.2).
- Empirical data from system in actual use demonstrating effectiveness of rapid cache validation in practice (Section 7.4.2.2).
- Experimental methodology based on trace replay, in which a workload from a file reference trace is replayed on the live system (Section 7.5.1).
- Controlled trace replay experiments confirming effectiveness of trickle reintegration over a three order of magnitude range in network bandwidth (Section 7.5.2).

9.2 Future Work

Although the system in its current form is useful, it could be improved in a number of ways. This rest of this section discusses directions for future work, in order of increasing scope. The narrowest scope represents enhancements to weakly connected operation. Work of medium scope represents more substantial extensions to the system as a whole. At the broadest scope are directions for new research.

9.2.1 Refinements for Weakly Connected Operation

Previous chapters have suggested a number of enhancements to the implementation. In general, they represent more sophisticated policies using the existing mechanisms described in those chapters. In the communications layer, the transport protocols described in Sections 3.2 and 3.3 could incorporate header and data compression. The bandwidth estimates Venus derives from the transmission logs, described in Section 3.4.3, could be improved in several ways. Venus could incorporate variance into its bandwidth estimates, and estimate conservatively when variance is high. If Mobile IP is available, the communications layer could incorporate information from upcalls generated when a mobile host changes location [56] as static entries deposited into its transmission logs.

For trickle reintegration, the selection of the aging window described in Section 5.4 could be adaptive to connection strength. At low bandwidths, Venus would use a large window to minimize data volume by taking advantage of log optimizations. At higher bandwidths, Venus would shrink the window because the benefits of propagating updates to the server outweigh the benefits of reducing the amount reintegrated. Section 5.3.2.2 describes another enhancement to trickle reintegration called selective reintegration, in which a user or program propagates updates to particular objects to the server. Finally, Venus could propagate file differences instead of file contents.

9.2.2 Incorporating Monetary Cost

This work has assumed that performance is the only metric of cost. In practice, many networks used in mobile computing cost real money. Where cost is prohibitive, Venus should conserve its use of the network just as it does when performance is very poor. This extension involves exploring techniques whereby Venus electronically inquires about network cost, and bases its adaptation on both cost and performance. Of course, full-scale deployment of this capability will require the cooperation of network providers and regulatory agencies.

9.2.3 Improving Effectiveness and Usability of Hoarding

As discussed in Chapter 6, servicing cache misses over a weak connection can be painfully non-transparent. Avoiding the performance penalty associated with a cache miss remains an important goal.

Hoarding is the current mechanism for caching for availability in Coda. However, experience has shown that novice users frequently forget to hoard critical files. Further, Maria Ebling found that the time to the first reference of a critical file was very small [36]. Thus she is exploring ways to improve caching for availability [35]. She argues that user assistance is

necessary to avoid cache misses while operating disconnected or weakly connected. Further, assistance should be provided to the system in an ongoing manner rather than a separate activity as in hoarding, and the information supplied by the user should be based on “tasks” rather than directories.

In addition, she is evaluating alternative strategies for caching for availability. This evaluation is difficult because the only caching metric available today is the miss ratio. This metric assumes that all cache misses are equal. However, while disconnected, cache misses do not exact the same penalty from the user. While weakly connected, cache misses can have wildly different service times. Further, the miss ratio does not take into account the timing of a miss – a user may react very differently to a cache miss at the beginning of a task than at the end. Ebling is exploring new caching metrics to evaluate the impact of different caching strategies on users and the accuracy of user assistance.

9.2.4 Exploiting Reserved Network Services

The communications layer assumes that the network provides no guarantees about performance. It assumes the network delivers data in a best-effort manner, and it simply observes the performance of its data transfers and derives estimates from those observations. There is a great deal of work on providing guaranteed or reserved services in both wired and wireless networks [27, 37, 38, 130]. An interesting extension to Coda would be to take advantage of reserved services when available. For example, the communication layer could adjust its retransmission strategy and frequency of round trip time measurements given a latency guarantee. Higher layers could take advantage of bandwidth guarantees to schedule file transfers.

9.2.5 Application-Level Logging

When connectivity is weak, a system must strive to minimize bandwidth requirements. An obvious way to reduce network usage is through compression, and several systems use this technique [2, 5]. However, more efficient communication may be possible by examining the activity at a higher level. For example, rather than shipping data between server and client, it may be more efficient to send operations.

This idea can be applied to the Coda CML. The CML can be viewed as an operation log for directories, and a value log for files. To incorporate function shipping into weakly connected operation, one could introduce *application-level logging*, in which the CML includes operation logging for files, and applications specify the operation. For example, consider a text editor replacing string `string1` with `string2`. The current implementation logs a `store` CML record with the new file data, and ships the new file data in its entirety to the server. In

application-level logging, the application would log a single CML record with the instructions for string replacement, and the server would perform the replacement upon receipt of the record.

High level operation logging places a greater burden on the server, because operations require greater computational resources. To preserve scalability, the system must take server load into account before agreeing to perform these functions. The client should negotiate operation logging rights upon connection, and the server should be able to revoke those rights if load becomes heavy.

9.2.6 Application-Aware Adaptation

This thesis has taken the approach of application transparent adaptation, placing the entire responsibility for adapting to network conditions on the file system. This approach is attractive because applications benefit from weakly connected support without modification. However, there are cases where adaptation performed by the file system is inappropriate for certain applications. For example, the file system operates weakly connected when the bandwidth to a server (or VSG) falls below a certain threshold. But from an application's point of view, a network connection is weak only when it imposes a significant bottleneck on the application's performance. One can imagine a compute-bound application that would not be weakly connected even at low speeds. On the other hand, there are applications that make an Ethernet look weak. Coda's simple thresholding policy does not take this observation into account.

Application transparent adaptation occupies one end of a spectrum of adaptation strategies. At the other end is the *laissez-faire* approach [112], which places the responsibility of coping with network conditions entirely upon the individual application. This approach allows applications to customize their handling of weak connectivity. However, it makes applications harder to write, because support for weak connectivity must be reinvented for each application. In addition, there is no way to arbitrate conflicting demands for resources between applications.

Between these two extremes is a spectrum of adaptation strategies referred to as *application aware adaptation* [112]. The application and system collaborate to allow applications to provide their own adaptation strategies, and the system to control and monitor resource usage between applications. This approach is being explored in the Odyssey system [90, 122] and work by Welling and Badrinath [129]. These systems provide an API that allows applications to monitor and react to changes in their environment, and support for resource management within the system.

9.3 Closing Remarks

Weak connectivity is a fact of life in mobile computing. The deep challenge of weak connectivity is not just poor network performance, but rather the variation in network performance over a wide range. This variation implies that a system cannot make *a priori* decisions about the performance impact of communication. It must adapt to network conditions, but in a way that does not preclude use of strong connectivity. The ideal system takes advantage of strong connectivity when available, but copes with weak connectivity when necessary. Further, it exploits periods of strong connectivity to improve quality of life during future periods of weak connectivity.

Disconnected operation is an invaluable starting point for this work. From the standpoint of a disconnected client, weak connectivity provides opportunities for improvement. This work was able to leverage off of the mechanisms for disconnected operation, such as update logging and reintegration, to exploit weak connectivity. Disconnected operation is still necessary, because it provides a viable fallback position when network conditions degrade beyond usability.

Performance, availability, and consistency are conflicting goals in distributed systems. This work trades consistency for performance and availability while weakly connected to allow the user to continue working with minimal interference. When strongly connected, performance, availability, and consistency are unaffected. The system strives to provide weakly connected performance comparable to that of a disconnected client, but with better consistency and availability. It maintains transparency as much as possible, but relaxes it where necessary in favor of usability. This adaptation is a crucial element for operating in weakly connected environments. Although network performance is improving, the wide range of network characteristics available will remain. Thus weakly connected operation will be a vital capability in future distributed systems.

Appendix A

Protocol Analysis

This chapter presents the details of the large granularity cache coherence protocol analysis. The first two sections present the system model, logic, and notation. The correctness criterion is stated formally in Section A.3. Section A.4 presents the analysis of the protocol. For simplicity the analysis assumes messages are received instantaneously; the effects of transmission delay and failures on correctness are discussed in Section A.5. The chapter closes with a discussion of simplifications made to the model, and how the definitions could be extended.

A.1 System Model

Hosts are designated clients or servers of the file system. Clients and servers communicate by sending messages to each other via remote procedure call [11]; each request made by one party requires a response from the other. The notation

$$C \rightarrow S : M$$

means client C sends a message M to server S .

Clients speak only to servers, not to other clients. The underlying communication protocol addresses end-to-end concerns such as guaranteeing authenticity and eliminating duplicate messages.

Exactly one repository, which could be one server or a group of servers, is the authority for a file system object. The generic term “server” refers to a repository. A file system object is any data stored by a server that may be cached at a client, including files, portions of files, file attributes, or version numbers.

The local state of a client, C , includes a set of cached data, $C.D$, and a set of beliefs, $C.B$, about objects in its cache. The local state of a server, S , includes the set of objects it stores,

$S.D$, and for each client C , a set of beliefs, $S_C.B$, that includes which objects are present in C 's cache and their validity.

The global state of the system is a tuple of all clients' and servers' local states, plus an *agreement set* A_{CS} , which determines for each data object d whose authority is S and is cached at C , whether the server and client copies are equal. It is this state variable that approximates global knowledge about the validity of all files. It represents pairwise knowledge, attained between connected pairs of clients and servers.

State transitions occur when a component of the global state changes. For the most part, this is when clients and servers exchange messages. The types of message exchanges are discussed in Section A.4.

The analysis makes statements about the presence or absence of file system objects cached at clients and their validity. An object is *valid* if it is the most recent copy in the system. Otherwise, it is *invalid*. Recency is determined by a timestamp associated with the file. The timestamp is replaced whenever the file is updated.

Since servers may not hear about updates immediately, validity is global knowledge and cannot always be determined by clients and servers. However, if C and S agree on an object, and S believes its copy is valid, then C should be able to conclude that its cached copy is valid. If S receives an update from a client other than C , then S is justified in telling C that its copy of the object is now invalid, regardless of the global validity of the updated copy.

Each protocol has a predefined set of initial and final messages. A *run* of a cache coherence protocol begins with an initial message and ends with a final message. Failures can terminate runs; they are detected by message timeouts. If a message times out, the principal that sent the message considers it a final message. However, if a client and server both believe a run is in progress, then the run ends once both principals detect the failure. An example of this appears in Section A.5.

Before a run, a client C considers all objects in its cache suspect; that is, it neither believes an object d is valid, nor believes d is invalid. During a run, C and S accumulate beliefs about d as a result of exchanging messages. At the end of the run, C and S discard their beliefs regarding the validity of d . If a run is not in progress, C must consider all cached objects suspect because it cannot check if they are valid, nor can S notify C that they are not.

A.2 Logic

The logic is a subset of the BAN logic [17, 18] with a few extensions. Below, P and Q are principals, which are either clients or servers. S refers to a server and C refers to a client. A message is denoted X ; a file system object d . The constructs are:

P **believes** X P behaves as if X is true.
 P **sees** X **from** Q P receives message X from Q .
 P **controls** X P is an authority on X .

The notions of belief and control are taken directly from the BAN logic. The statement P **believes** X is equivalent to $X \in P.B$, where $P.B$ is the belief set for principal P . The **sees** construct is derived from the BAN logic based on our assumptions about the underlying communication mechanism.

The following constructs, extensions to the BAN logic, are for reasoning about file system objects:

$d \in P$ P has a copy of d , i.e., $d \in P.D$. The copy held by P is denoted d_P ¹.
 $valid(d_P)$ The value of d 's timestamp at P is greater than or equal to the timestamp associated with every other copy of d in the system.

Messages can contain the above two constructs and their negations. As in the BAN logic, a message X may consist of formulae, data, or both. For example, a message might contain a formula about some object d such as $valid(d_C)$, or it might contain the object itself (simply d). Messages may be classified further based on their contents. For example, the various kinds of update requests form one class of messages. An update request involving object d is denoted $update(d)$.

Belief sets can contain the above two constructs and their negations, as well as statements of the form “ P **believes** X ”.

The axioms of the logic are:

- A1. $\forall d \in C.D$ (C **believes** $d \in C$)
- A2. $\forall d \notin C.D$ (C **believes** $d \notin C$)
- A3. P **believes** $X \Rightarrow \neg(P$ **believes** $\neg X)$

The first two axioms simply state that client C is allowed to believe what it knows about the contents of its cache.

The third axiom says belief sets must be internally consistent. In the BAN logic, beliefs are *stable*, meaning that once a principal holds a belief, it holds that belief for the duration of the protocol. Thus during their protocols, belief sets only grow. In contrast, in a file system cached files may become invalid because of updates. Because of this, beliefs about the validity of files may change. Axiom 3 guarantees at most one of X and $\neg X$ appears in P 's belief set. If a new belief is derived during a run that contradicts a currently held belief about d ,

¹Although P is a parameter, it is more readable as a subscript.

the new belief *supersedes* the old one because it is based on more recent information. Thus if $C.B = \{ \text{valid}(d_C) \}$, and a message arrives invalidating d_C , then $C.B$ would become $\{ \neg \text{valid}(d_C) \}$.

The converse of A3, $\neg(P \text{ believes } X) \Rightarrow (P \text{ believes } \neg X)$, does not hold. In other words, absence of belief is distinct from belief of the opposite.

It may be the case that principal P has no beliefs regarding X , i.e., it believes neither X nor $\neg X$. Since $X \in P.B$ is equivalent to $P \text{ believes } X$, then $X \notin P.B$ is equivalent to $\neg(P \text{ believes } X)$. Thus, for example, if $\text{valid}(d_P)$ does not appear in P 's belief set, then one can say $\neg(P \text{ believes } \text{valid}(d_P))$. Again, this does not mean that P believes d_P is invalid, as explained above.

The inference rules in the logic are:

- R1. The *visibility rule* says if a principal sees a message, it sees its components. This rule is taken from the BAN logic.

$$\frac{P \text{ sees } X, Y \text{ from } Q}{P \text{ sees } X \text{ from } Q, P \text{ sees } Y \text{ from } Q}$$

- R2. The *message interpretation rule* says if a principal sees a message, it can believe that the sender believes what it said in the message. This is derived from the BAN message meaning and nonce-verification rules, and it follows from assumptions about the underlying communication mechanism.

$$\frac{P \text{ sees } X \text{ from } Q}{P \text{ believes } Q \text{ believes } X}$$

- R3. The *jurisdiction rule*, taken directly from the BAN logic, says if P believes Q is an authority on X , then P may believe whatever Q believes about X .

$$\frac{P \text{ believes } Q \text{ controls } X, P \text{ believes } Q \text{ believes } X}{P \text{ believes } X}$$

- R4. The *update rule* says observers of an update invalidate old versions of the updated data. Below, $C' \neq C$, and S is the repository for d .

$$\frac{S \text{ believes } \text{valid}(d_C), S \text{ sees } \text{update}(d) \text{ from } C'}{S \text{ believes } \neg \text{valid}(d_C)}$$

A.3 Goal of Cache Coherence

The goal of a cache coherence protocol is to ensure that no invalid object is ever portrayed as being valid. That is, for all clients C and objects d ,

$$\text{if } C \text{ believes } \text{valid}(d_C) \text{ then } \text{valid}(d_C)$$

This is not achievable in practice because the system model allows partitioned updates. However, a weaker version of this statement is a practical *correctness criterion*: for all clients C , servers S , and objects d for which S is the repository,

$$\text{if } C \text{ believes } \text{valid}(d_C) \text{ then } S \text{ believes } \text{valid}(d_C)$$

Notice that the correctness criterion is defined on a per-object basis. The aim of a run is to establish the correctness criterion for as many cached objects as possible.

Unlike authentication, cache coherence is not a final system state to be achieved after running the protocol, but an invariant to be maintained while running it. To argue a cache coherence protocol correct, our obligation is to prove the invariance of the correctness criterion over each run of the protocol.

A.4 Protocol Analysis

This section presents an analysis of the large granularity protocol. The protocol is reviewed briefly, and the initial and final messages are defined. Then the smallest system possible in which the protocol could operate is defined. The possible states of a client and server are listed, determining all possible valid runs. Correctness arguments for each follow, assuming initially that message transmission and failure detection occur instantly. The effect of transmission delays and failures is discussed in Section A.5.

The following assumptions apply to all runs:

- S1. $\forall d \in S.D \ (S \text{ believes } \text{valid}(d_S))$
 S2. $\forall d \in S.D \ d \in C \Rightarrow (C \text{ believes } S \text{ controls } \text{valid}(d_C))$
 S3. $\forall d \in S.D \ d \in C \Rightarrow (C \text{ believes } S \text{ controls } \neg \text{valid}(d_C))$

The first assumption states that a server believes all the data it stores is valid. The last two assumptions say a server is the authority on the validity of data it stores.

As described in Chapter 4, the large granularity cache coherence protocol allows callbacks to be maintained on *volumes* in addition to or instead of files. A callback on a volume constitutes proof that all cached files in the volume are valid. To establish a volume callback, the client caches the version number for the volume. The server increments the volume version number whenever a file in that volume is updated.

A run of this protocol concerns a file f , and optionally the version number v from volume V containing f . Before requesting v , the client must have at least one file in V in its cache, and all cached files in V must be valid. This requirement ensures the files at C correspond to the version number it receives.

A client may validate v just as it would a file. If it has both file and volume state at the beginning of a run, it may validate them in either order. If a client validates v successfully, it receives a callback for the volume. While holding the volume callback, no communication is necessary to read any file cached in the volume.

In this protocol, a client may send a server a *fetch* request for new data, a *validation* of already cached data, or an *update*. Servers may respond to fetch and validation requests with new data, and an indication if already cached data is valid. Update requests additionally cause servers to send *invalidation* messages to clients caching the updated data. The initial messages for this protocol are any one of the following: a fetch for a file or a version number, or a validation for a file or a version number.

Final messages for the protocol are the response to a file invalidation and a failed file validation. A volume invalidation response or a failed volume validation are also final messages if there is no callback on the file. The run ends when the *file* is discarded or rendered suspect.

This protocol may be analyzed considering one client, C , one server, S , one file, f , and one volume V with version number v . The system state is again a tuple of four variables, $(C.D, C.B, S.B, A)$, where

- $C.D$ ranges over $\emptyset, \{f\}$, and $\{f, v\}$. This means if the volume version number is cached then so is a file from that volume.²

²This analysis uses a simplified model consisting of only f and v , even though in practice it would take more than one file to make obtaining a volume callback worthwhile. This is discussed in Section A.7.

- A is the agreement set on the cached objects. It ranges over the following values:

$$\emptyset, \{f_C = f_S\}, \{f_C \neq f_S\}, \{f_C = f_S, v_C = v_S\} \\ \{f_C = f_S, v_C \neq v_S\}, \{f_C \neq f_S, v_C \neq v_S\}$$

Note that because the volume version number is updated whenever an object in the volume is updated, it is not possible for f to be invalid and v to be valid at the same time.

A run of the protocol maps some initial state $(C.D_i, C.B_i, S.B_i, A_i)$ to some terminating state $(C.D_t, C.B_t, S.B_t, A_t)$. The state space is restricted in the following ways. For all states, $(C.D, C.B, S.B, A)$, in a run:

1. For each object d (f or v) in $C.D$, $d_C = d_S$ or $d_C \neq d_S$ must be in A . If $C.D = \emptyset$ then $A = \emptyset$.
2. When an object is invalidated, the client must discard it. An invalidation for the file is an implicit invalidation for the volume. More precisely,

$$(f_C \neq f_S) \in A \Rightarrow C.D_t = \emptyset$$

$$(v_C \neq v_S) \in A \Rightarrow v \notin C.D_t$$

3. At the end of a run, either d is not cached, or it is cached and agrees with the server. This follows from 2 above, because once the client discovers d is invalid it discards it. Thus $A_t = \emptyset$ or $A_t = \{d_C = d_S\}$.

Runs of the protocol are classified by the initial and final cache contents of the client ($C.D_i$ and $C.D_t$) and by the initial agreement set (A_i). (A_t is not relevant because it will either be empty or indicate agreement as stated in item 3 above.) Multiple runs may correspond to each combination of $C.D_i$, $C.D_t$, and A_i . The set of runs corresponding to these state variables is a *class* of runs. There are fifteen possible classes of runs of the protocol. The client state transition diagram is shown in Figure A.1. For each object in $C.D_i$, the contents of the agreement set determines whether the first transition concerning the object is a validation or a failed validation.

Individual runs (or classes of runs) are analyzed in the following subsections. The first five runs concern files only, and correspond to all possible runs in the original cache coherence protocol. Analogous runs for volume data are mentioned where they exist. Section A.4.6 illustrates a loop in the client state transition diagram by discussing a volume miss with no failures. The final run shown in this section is a volume validation followed by a communication failure. This run is the common case in intermittent network environments.

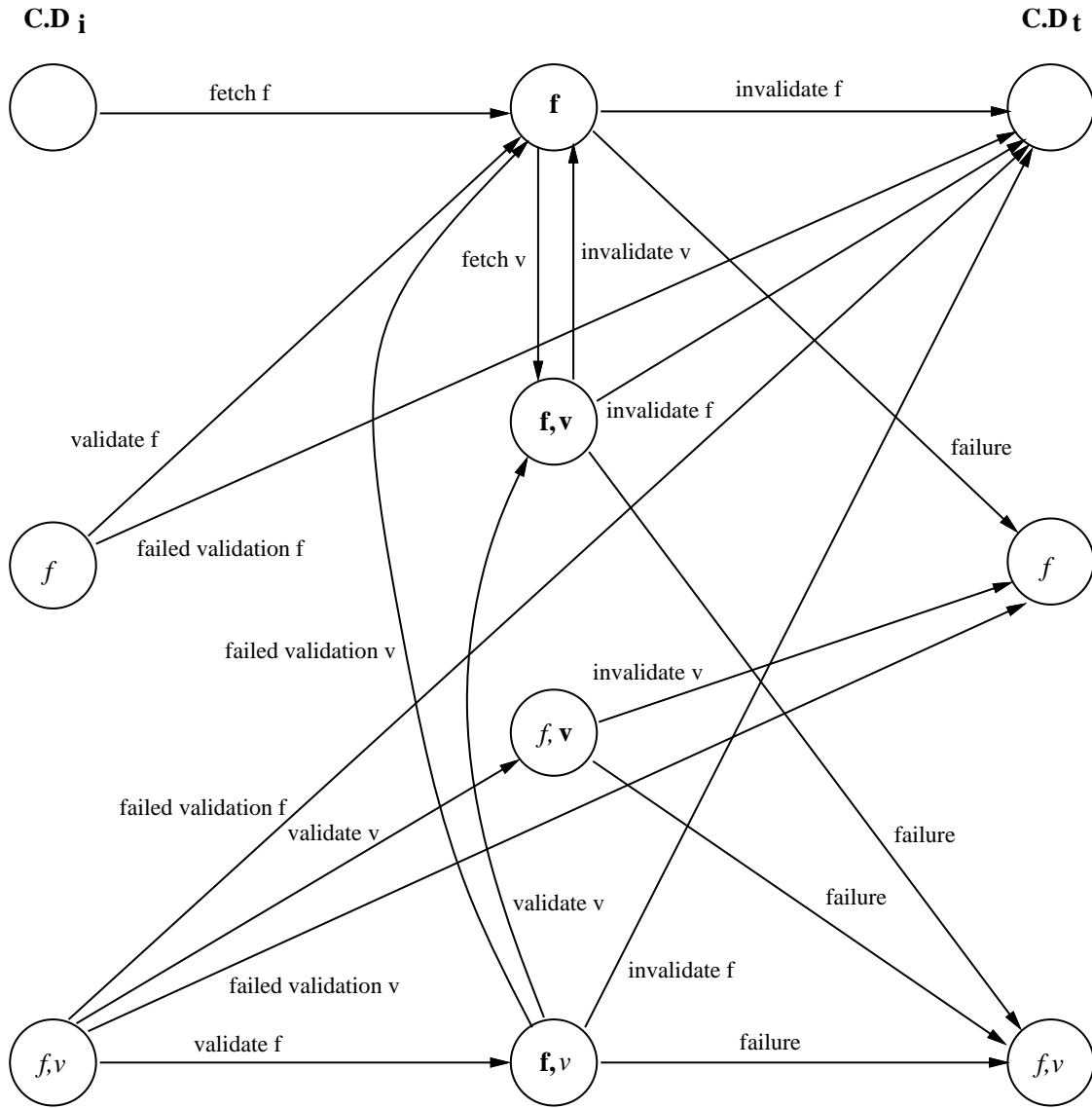

Figure A.1: Client State Transitions – Invalidation Based, Large Granularity

This is the state transition diagram for the client for a file-volume pair (f, v) . The leftmost states correspond to the client cache contents at the beginning of the run, $C.D_i$. Similarly, the rightmost states correspond to the client cache contents at the end of the run, $C.D_t$. An object in boldface means the client has a callback for the object. If object $x \in C.D_i$, a “validate” transition is taken if $(x_C = x_S) \in A$, otherwise a “failed validation” transition occurs.

The proof of invariance is based on either f_C or v_C , depending on which callback, if any, is established first. It is never the case that the client switches from depending on one type of callback to another during the run. If the proof of invariance concerns v_C , and f_C is contained by the volume whose version number is v_C , if C **believes** $valid(v_C)$ then it can be confident that $valid(f_C)$ as well.

A.4.1 Cache miss, no failures

The critical transitions for the client are a fetch of f , and an invalidation of f . The initial and final system states for this run are both $(\emptyset, \{f \notin C\}, \emptyset, \emptyset)$. This run corresponds to the topmost path in Figure A.1.

The run proceeds as follows. A request involving f is issued at C , however f is not present in C 's cache. C sends the initial message to S requesting a copy of f . S records the fact that C is caching f ($f \in C$ on S). This is the callback promise. When C receives the response from S , it may use the data to service requests for f until S tells it otherwise. Since no failures occur in this case, eventually some other client updates f , rendering C 's copy invalid. The server sends C an invalidation message (the callback break), causing C to discard its copy of f . C sends the final message to S indicating that it received the invalidation, and S discards its callback promise on f for C .

The evolution of C 's and S 's beliefs as the protocol is shown below.

C believes	Message	S believes	Notes
$f \notin C$	$C \rightarrow S : f \notin C$		cache miss request f
	$S \rightarrow C : f, \text{valid}(f_C), f \in C$	$f \in C, \text{valid}(f_C)$	record callback promise send f , callback status
$f \in C$ S believes $f \in C$ $\text{valid}(f_C)$	\vdots		
	$C' \rightarrow S : \text{update}(f)$		C' updates f C' 's copy stale
	$S \rightarrow C : \neg \text{valid}(f_C)$	$f \in C, \neg \text{valid}(f_C)$	callback break for f_C
$f \in C$ S believes $f \in C$ $\neg \text{valid}(f_C)$			supersedes $\text{valid}(f_C)$
$f \notin C$ [S believes $f \in C$] [$\neg \text{valid}(f_C)$]	$C \rightarrow S :$		C discards f C erases beliefs
		[$f \in C, \neg \text{valid}(f_C)$]	response to invalidation erase callback promise

Since $\text{valid}(f_C) \notin C.B, \neg(C \text{ believes } \text{valid}(f_C))$. Thus the invariant is established.

The next event that changes the system state occurs when S responds to C 's request. Using assumption S1 stated at the beginning of this section, S believes $\text{valid}(f_S)$. Since $f_C = f_S$ when S sends f , it is also the case that S believes $\text{valid}(f_C)$.

When C receives the response from S , C sees $f, \text{valid}(f_C), f \in C$ from S . Using the visibility rule, C sees $\text{valid}(f_C)$ from S . Using the message interpretation rule C believes S believes $\text{valid}(f_C)$. Using the jurisdiction rule instantiated with $\text{valid}(f_C)$, C believes $\text{valid}(f_C)$. But since S believes $\text{valid}(f_C)$, the invariant still holds.

When the remote update to f occurs, S receives a message containing an update request involving f from some client $C' \neq C$. That is, S sees $\text{update}(f)$ from C' . Using the update rule, S believes $\neg \text{valid}(f_C)$. S sends C an invalidation message for f_C . If the message arrives at C instantaneously, both parties change their beliefs at the same instant and the invariant still holds. Of course, the message does not arrive instantaneously. This is discussed in Section A.5.

When C receives the invalidation message, C **sees** $\neg\text{valid}(f_C)$ **from** S . Using message interpretation, C **believes** S **believes** $\neg\text{valid}(f_C)$. Using assumption S3 and the jurisdiction rule instantiated for $\neg\text{valid}(f_C)$, C **believes** $\neg\text{valid}(f_C)$. This supersedes C **believes** $\text{valid}(f_C)$. Since belief sets must be internally consistent (axiom A3), $\neg(C$ **believes** $\text{valid}(f_C)$) and the invariant holds.

C discards f and responds to the invalidation message, ending the run. Since C no longer has a copy of f , clearly $\text{valid}(f_C) \notin C.B$, and therefore $\neg(C$ **believes** $\text{valid}(f_C)$). Thus at the end of the run, the invariant holds.

A.4.2 Successful validation, no failures

This run begins with f already cached at C . Since f is suspect, on the first reference C attempts to validate f with S . In this case S replies that it is valid, and records a callback for f at C . The rest of this case is the same as in Section A.4.1. Initial and final states are $(\{f\}, \{f \in C\}, \emptyset, \{f_C = f_S\})$ and $(\emptyset, \{f \notin C\}, \emptyset, \emptyset)$.

C believes	Message	S believes
$f \in C$	$C \rightarrow S : f \in C$	
		$f \in C, \text{valid}(f_C)$
	$S \rightarrow C : \text{valid}(f_C), f \in C$	
$f \in C$		
S believes $f \in C$		
$\text{valid}(f_C)$	\vdots	
	$C' \rightarrow S : \text{update}(f)$	
		$f \in C, \neg\text{valid}(f_C)$
	$S \rightarrow C : \neg\text{valid}(f_C)$	
$f \in C$		
S believes $f \in C$		
$\neg\text{valid}(f_C)$		
$f \notin C$		
$[S$ believes $f \in C]$		
$[\neg\text{valid}(f_C)]$	$C \rightarrow S :$	$[f \in C, \neg\text{valid}(f_C)]$

Initially C cannot be certain of the validity of f_C , so $valid(f_C) \notin C.B$ and therefore $\neg(C \text{ believes } valid(f_C))$. Thus the invariant is established.

C sends the validation request for f to S . $S \text{ believes } valid(f_S)$ using assumption S1. Since $f_C = f_S$, in this case $S \text{ believes } valid(f_C)$, and the invariant still holds.

When C receives the response, $C \text{ sees } valid(f_C) \text{ from } S$. Using message interpretation yields $C \text{ believes } S \text{ believes } valid(f_C)$, and applying jurisdiction $C \text{ believes } valid(f_C)$. Since $S \text{ believes } valid(f_C)$ the invariant holds.

The rest of the proof is identical to Section A.4.1.

A.4.3 Cache miss, followed by failure

This case begins as in Section A.4.1, but ends when a failure severs the connection between C and S . Initial and final states are $(\emptyset, \{f \notin C\}, \emptyset, \emptyset)$, and $(\{f\}, \{f \in C\}, \emptyset, \{f_C = f_S\})$.

C believes	Message	S believes
$f \notin C$		
	$C \rightarrow S : f \notin C$	
		$f \in C, valid(f_C)$
	$S \rightarrow C : f, valid(f_C), f \in C$	
$f \in C$ $S \text{ believes } f \in C$ $valid(f_C)$:	
	failure	
$f \in C$ [$S \text{ believes } f \in C$] [$valid(f_C)$]		[$f \in C, valid(f_C)$]

As in Section A.4.1, $S \text{ believes } valid(f_C)$ when it responds to C 's request, and $C \text{ believes } valid(f_C)$ when it receives the reply from S . The invariant holds until the failure occurs.

When S detects the failure, it discards its beliefs about C . This includes beliefs about which objects C has cached, and the validity of those objects. When C detects the failure, it discards its beliefs about S , and the validity of objects in its cache. It retains beliefs about the presence or absence of objects in its cache. These beliefs are always derivable using the axioms, because they are based on strictly local information. C and S react conservatively because they cannot distinguish between a communication failure and a machine failure. For example, if C loses

contact with S , it may be because S crashed. If S crashes, callback information is lost. C cannot rely on S retaining callback information, so it must consider its f suspect.

A.4.4 Successful validation, failure

C believes	Message	S believes
$f \in C$	$C \rightarrow S : f \in C$	$f \in C, \text{valid}(f_C)$
$f \in C$ S believes $f \in C$ $\text{valid}(f_C)$	$S \rightarrow C : \text{valid}(f_C), f \in C$	
	⋮	
$f \in C$ [S believes $f \in C$] [$\text{valid}(f_C)$]	failure	[$f \in C, \text{valid}(f_C)$]

This case begins as in Section A.4.2 and ends as in Section A.4.3. Initial and final states are both $(\{f\}, \{f \in C\}, \emptyset, \{f_C = f_S\})$.

The proof of invariance begins as in Section A.4.2. When C receives the response from S , C believes $\text{valid}(f_C)$, S believes $\text{valid}(f_C)$, and the invariant holds. The rest of the proof is as in Section A.4.3.

A.4.5 Failed validation

As above, the protocol begins with f already cached at C . Since f is suspect, C attempts to validate it with S . In this case S replies that it is not valid. No state about f at C is recorded at the server. When C receives the reply, it discards its copy of f . Initial and final states for this run are $(\{f\}, \{f \in C\}, \emptyset, \{f_C \neq f_S\})$ and $(\emptyset, \{f \notin C\}, \emptyset, \emptyset)$.

C believes	Message	S believes
$f \in C$	$C \rightarrow S : f \in C$	$\neg \text{valid}(f_C)$
$f \in C$ $\neg \text{valid}(f_C)$	$S \rightarrow C : \neg \text{valid}(f_C)$	
$f \notin C$ [$\neg \text{valid}(f_C)$]		

This run is vacuously correct because at no time does C believe f is valid. That is, the invariant holds throughout because $\neg(C \text{ believes } \text{valid}(f_C))$. The same reasoning applies to f if $v \in C$ initially (i.e. from initial state $(\{f, v\}, \{f \in C, v \in C\}, \emptyset, \{f_C \neq f_S, v_C \neq v_S\})$). In this case the client discards v as well as f , resulting in the same final state as above. The same reasoning also applies to v , if C attempts to validate v before f , from initial states $(\{f, v\}, \{f \in C, v \in C\}, \emptyset, \{f_C = f_S, v_C \neq v_S\})$ and $(\{f, v\}, \{f \in C, v \in C\}, \emptyset, \{f_C \neq f_S, v_C \neq v_S\})$. The final states for these runs are $(\{f\}, \{f \in C\}, \emptyset, \{f_C = f_S\})$ and $(\{f\}, \{f \in C\}, \emptyset, \{f_C \neq f_S\})$, respectively.

A.4.6 Volume miss, no failures

In this case, the client establishes a volume callback by fetching the volume version stamp. The run is shown in progress with f already cached at C and valid, to address all runs containing this state, which corresponds to the topmost middle state of Figure A.1. C requests and receives a volume callback, so that it has callbacks on both f and v . Eventually f is updated from another client. Because the invalidation for f also serves as an invalidation for v , C discards both and the run ends. There are four possible initial states for the run segment shown in this section – $(\emptyset, \{f \notin C, v \notin C\}, \emptyset, \emptyset)$, $(\{f\}, \{f \in C, v \notin C\}, \emptyset, \{f_C = f_S\})$, $(\{f, v\}, \{f \in C, v \in C\}, \emptyset, \{f_C = f_S, v_C = v_S\})$, and $(\{f, v\}, \{f \in C, v \in C\}, \emptyset, \{f_C = f_S, v_C \neq v_S\})$ ³. The final state for these runs is $(\emptyset, \{f \notin C, v \notin C\}, \emptyset, \emptyset)$.

While C has the volume callback, another client could update an object in the volume other than f . This is an example of false sharing. Such an update would break C 's volume callback, but because C still had a callback on f , the run would persist until f itself was updated.

First consider the case in which no object in V is updated remotely before f .

³In practice the latter two would not occur because the implementation validates v before f , resulting in different runs.

C believes	Message	S believes	Notes
$f \in C$ $valid(f_C)$ $S \text{ believes } f \in C$	$C \rightarrow S : v \notin C$ $S \rightarrow C : v, v \in C$	$f_C \in C$ $valid(f_C)$ $v \in C, valid(v_C)$	request V 's version stamp record callback send stamp, callback status
$f \in C, v \in C$ $S \text{ believes } f \in C$ $S \text{ believes } v \in C$ $valid(f_C), valid(v_C)$	\vdots $C' \rightarrow S : update(f)$ $S \rightarrow C : \neg valid(f_C)$	$f \in C, \neg valid(f_C)$ $v \in C, \neg valid(v_C)$	C' updates f f_C, v_C now invalid callback break for f_C
$f \in C, v \in C$ $S \text{ believes } f \in C$ $S \text{ believes } v \in C$ $\neg valid(f_C), \neg valid(v_C)$			
$f \notin C, v \notin C$ $[S \text{ believes } f \in C]$ $[S \text{ believes } v \in C]$ $[\neg valid(f_C), \neg valid(v_C)]$	$C \rightarrow S :$	$[f \in C, \neg valid(f_C)]$ $[v \in C, \neg valid(v_C)]$	C discards f, v C erases beliefs C responds to invalidation erase callback promises

Now assume an update occurs on some object g in V , where $g \notin C$, during the \vdots above.

C believes	Message	S believes	Notes
$f \in C, v \in C$ $valid(f_C), valid(v_C)$ S believes $f \in C$ S believes $v \in C$		$f \in C, v \in C$ $valid(f_C), valid(v_C)$	
	\vdots		
	$C' \rightarrow S : update(g)$		$C' \neq C$ updates $g \notin C$
		$f \in C, valid(f_C)$ $v \in C, \neg valid(v_C)$	v_C now invalid invalidate v_C
	$S \rightarrow C : \neg valid(v_C)$		
$f \in C, v \in C$ S believes $f \in C$ S believes $v \in C$ $valid(f_C), \neg valid(v_C)$			supersedes $valid(v_C)$
$f \in C, v \notin C$ S believes $f \in C$ $valid(f_C)$			C discards v
$[S$ believes $v \in C]$ $[\neg valid(v_C)]$			C erases beliefs
	$C \rightarrow S :$		
		$[v \in C, \neg valid(v_C)]$ $f \in C, valid(f_C)$	C responds to invalidation erase callback promise

At this point C is back where it started. C could conceivably loop, obtaining and losing the callback on V , as shown in the topmost middle states of Figure A.1. This loop may occur in any run once C holds a callback on f , including those shown in Sections A.4.1 to A.4.4. In the runs ending with a failure, if $v \in C$ the client retains v (but drops the callback) just as it does f . In the run above, the update to f could occur while $v \in C$ or not; either way the run ends without v .

The proof of invariance for f_C is as in section Section A.4.1 if f was fetched, or Section A.4.2 if f was validated successfully. The presence or absence of v at C has no effect on beliefs regarding f because C has a callback on f . During this run, there is no benefit derived from obtaining the volume callback; its strength in providing quick validation is not part of this run.

A.4.7 Volume miss, failure

This case begins as in Section A.4.6 but ends when a failure severs the connection between C and S . Note that as in Section A.4.6 C may obtain and lose a callback on V repeatedly before the failure.

The final state for this run is $(\{f, v\}, \{f \in C, v \in C\}, \emptyset, \{f_C = f_S, v_C = v_S\})$ if v is not invalidated before the failure, otherwise it is $(\{f\}, \{f \in C\}, \emptyset, \{f_C = f_S\})$. The proof of invariance for f_C is as in Section A.4.6; the invariant holds until the failure occurs as in Section A.4.3.

A.4.8 Volume validation, failure

From the client's viewpoint, this run corresponds to the path in Figure A.1 from state (f, v) to (f, \mathbf{v}) to (f, v) . The critical transitions for the client are the validation of v and detection of a failure. The initial and final system states for this run are $(\{f, v\}, \{f \in C, v \in C\}, \emptyset, \{f_C = f_S, v_C = v_S\})$.

When this run begins, C already has volume and file state in its cache. C sends V 's identifier and volume version number v to the server to determine if anything in V has been updated. In this case, the validation is successful (i.e., nothing has changed), so C may assume all cached state from V is valid. In addition, C receives a callback promise for V , meaning S will notify C if anything in V changes. At this point C may consider all files in V valid, even though this analysis considers only f . The run ends when a failure severs the connection between C and S .

C believes	Message	S believes
$f \in C, v \in C$		
	$C \rightarrow S : v \in C$	
		$v \in C, \text{valid}(v_C)$
	$S \rightarrow C : v \in C, \text{valid}(v_C)$	
$f \in C, v \in C$ $\text{valid}(v_C)$ S believes $v \in C$	\vdots	
	failure	
$f \in C, v \in C$ [S believes $v \in C$] [$\text{valid}(v_C)$]		[$v \in C, \text{valid}(v_C)$]

Initially C cannot be certain of the validity of v_C , so $\text{valid}(v_C) \notin C.B$ and therefore $\neg(C \text{ believes } \text{valid}(v_C))$. Thus the invariant is established.

C sends the validation request for v to S . Using assumption S1, we obtain **S believes** $\text{valid}(v_S)$. Since $v_C = v_S$ in this case, we have **S believes** $\text{valid}(v_C)$, and the invariant still holds.

When C receives the response, we have C **sees** $\text{valid}(v_C)$ **from** S . Using message interpretation we have **C believes** **S believes** $\text{valid}(v_C)$. Using assumption S2 and the jurisdiction rule, we have **C believes** $\text{valid}(v_C)$. Since **S believes** $\text{valid}(v_C)$ the invariant holds.

When S detects the failure, it discards its beliefs about C . This includes beliefs about which objects C has cached, and the validity of those objects. When C detects the failure, it discards its beliefs about S , and the validity of objects in its cache. It retains beliefs about the presence or absence of objects in its cache; these beliefs are always derivable using the axioms, because they are based on strictly local information.

A.4.9 Volume validation, no failures

This run begins as in Section A.4.8, but ends when C receives an invalidation for f or v . The final state for this run is $(\emptyset, \{f \notin C, v \notin C\}, \emptyset, \emptyset)$ if f is invalidated, otherwise it is $(\{f\}, \{f \in C\}, \emptyset, \{f_C = f_S\})$.

Below are the beliefs of C and S for a run in which f is invalidated.

C believes	Message	S believes
$f \in C, v \in C$	$C \rightarrow S : v \in C$	$v \in C, \text{valid}(v_C)$
	$S \rightarrow C : v \in C, \text{valid}(v_C)$	
$f \in C, v \in C$ $\text{valid}(v_C)$ S believes $v \in C$	\vdots	
	$C' \rightarrow S : \text{update}(f)$	$f \in C, \neg \text{valid}(f_C)$ $v \in C, \neg \text{valid}(v_C)$
	$S \rightarrow C : \neg \text{valid}(f_C)$	
$f \in C, v \in C$ S believes $v \in C$ $\neg \text{valid}(f_C), \neg \text{valid}(v_C)$		
$f \notin C, v \notin C$ [S believes $v \in C$] [$\neg \text{valid}(f_C), \neg \text{valid}(v_C)$]	$C \rightarrow S :$	[$v \in C, \neg \text{valid}(v_C)$]

For a run in which v is invalidated, the beliefs are:

C believes	Message	S believes
$f \in C, v \in C$	$C \rightarrow S : v \in C$	
		$v \in C, \text{valid}(v_C)$
	$S \rightarrow C : v \in C, \text{valid}(v_C)$	
$f \in C, v \in C$ $\text{valid}(v_C)$ S believes $v \in C$	\vdots	
	$C' \rightarrow S : \text{update}(g)$	
		$v \in C, \neg \text{valid}(v_C)$
	$S \rightarrow C : \neg \text{valid}(v_C)$	
$f \in C, v \in C$ S believes $v \in C$ $\neg \text{valid}(v_C)$		
$f \in C, v \notin C$ [S believes $v \in C$] [$\neg \text{valid}(v_C)$]	$C \rightarrow S :$	[$v \in C, \neg \text{valid}(v_C)$]

A.4.10 Other validations

When both f and $v \in C.D_i$, they may be validated in either order. Different orders result in different runs. The remainder of the runs in the analysis involve C attempting to validate f before v . These runs do not occur in practice because the implementation always validates v first if present.

If C validates f successfully before it attempts to validate v , the proof of invariance is based on f as in Section A.4.2 if an invalidation for f ends the run, or as in Section A.4.4 if a failure occurs. During the run, the client could attempt to validate v , refetching it if necessary, and it could loop as in Section A.4.6. The final states of such runs depend on A_i , and whether or not $v \in C.D$ when the terminating event occurs.

A.5 Time-Bounded Correctness

Two factors complicate reasoning about correctness in distributed systems: transmission delay and failures. During the interval in which a message is traveling, the sender may have made some state change that renders the correctness condition false until the receiver processes the message and changes its state. While transmission time is often assumed to be negligible in LAN-based environments, this assumption is not valid in weakly connected environments. However, transmission delay is loosely bounded by the timeout period used by the underlying communication protocol, denoted by β . If a message is not acknowledged within β after it is sent, the sender declares a failure. The timeout period is a system parameter, and is usually on the order of a minute.

Failures are the second complication. It takes time for principals to detect failures. During the interval between the occurrence of a failure and its detection, it is possible for the correctness condition to be false because one of the principals was unable to notify another of some event. This interval, denoted by τ , defines a window of vulnerability for the protocol. To bound the failure detection interval, clients and servers probe each other periodically, and declare failures if messages time out. Let β be the message timeout period as above, and let ρ be the probe interval. Assume clients and servers use the same probe interval, but do not necessarily probe each other at the same time. Then the failure detection interval $\tau = \rho + \beta$ at most.

The timetable in Figure A.2 shows the worst-case behavior of a system whose failure detection interval is τ . Let t_p be the latest time at which C probes S successfully before the failure, and let t_f be the time at which the failure occurs. Eventually either C or S will send a message and discover the failure. If the failure is discovered through a probe by either party, C was still correct in believing that f_C was valid, even though C 's and S 's beliefs about callback state were not consistent.

The worst case occurs if another client in contact with S updates f while C is partitioned from S , but before C has detected the failure. S tries to break C 's callback on f at time t_i but fails. This is a *lost callback*. During this interval, C believes that f_C is valid when it is not. This interval is largest when the failure and the update occur immediately after t_p . At time $t_i + \beta$, C is still blissfully ignorant of the status of f , and does not discover a problem until it tries to contact S at $t_p + \rho$. It is not until $t_p + \tau$ that C declares failure and demotes f to suspect status. Thus τ is the longest period in which C can believe f is valid when it is not.

Correctness for this protocol is bounded by τ . A protocol τ -correct if the interval in which it does not meet the correctness criterion is at most τ . A 0-correct protocol obeys the correctness criterion strictly. In the Coda file system, τ is composed of a probe interval of 10 minutes, and a message timeout of 15 seconds.

C believes	Message	S believes	Notes
$f \in C, \text{valid}(f_C)$ S believes $f \in C$		$f \in C, \text{valid}(f_C)$	
	\vdots		
	$C \rightarrow S : \text{probe}$		t_p , probe successful
	\vdots		
	failure		t_f , C and S partitioned
	\vdots		
		update f $\neg \text{valid}(f_C)$	C' updates f
	$S \rightarrow C : \neg \text{valid}(f_C)$	$[f \in C]$	t_i $t_i + \beta$, S declares failure
	\vdots		
	$C \rightarrow S : \text{probe}$		$t_p + \rho$ $t_p + \rho + \beta = t_p + \tau$, C declares failure
$f \in C$ [S believes $f \in C$] [$\text{valid}(f_C)$]			C erases beliefs

Figure A.2: Worst Case Behavior During a Failure

A.6 Classifying Beliefs

Beliefs can be classified in three ways. *Correct beliefs* are those beliefs that are actually true. *Pessimistic beliefs* refer to beliefs that are discarded when a run ends. In effect, this set captures those objects for which there are no beliefs. Finally, it is possible to have *temporarily false beliefs* because correctness is time bounded, as described in Section A.5.

Viewed in this way, the goal of a cache coherence protocol is to establish correct beliefs. When a run begins, all beliefs are essentially pessimistic. As the run proceeds, correct beliefs gradually replace pessimistic beliefs. Given a fixed number of objects, the set of pessimistic beliefs becomes empty after some bounded period of connectivity. Because of failures, the set of temporarily false beliefs may be non-empty. However, Section A.5 shows that no belief remains in that subset for longer than τ .

A.7 Extensions

This analysis is oversimplified in two respects. First, it considers only a single f and v , even though in practice it would take more than one file to make obtaining a volume callback worthwhile. Given this simplified model, we must exclude the states where $C.D = \{v\}$ because there must be at least one file present to obtain a volume callback. In practice, this value for $C.D$ is permissible provided there are other files in volume V cached at the client.

Second, although a repository may consist of a group of servers, the analysis ignores some of the practical aspects of replication. For example, if the client uses a replicated volume, it must collate responses from multiple servers. One complication is that the client may receive responses from only a subset of the servers because of failures. A small change to the definition of a run takes care of this problem. For a replicated service, the run ends when the number of servers communicating with the client changes. This is natural because if the number shrinks, there exists the potential for a lost callback from a server that disappeared. If the number grows, a newly available server may hold updated versions of cached data.

The notion of a run could be extended in other ways. For example, some systems incorporate expiration times in their cache coherence mechanism [43]. We can address this by extending the definition of a run such that when a token or lease expires, the run ends.

The update rule is applied only at servers. The rule could be extended to apply to any principal in systems where clients observe updates through broadcasts. This extension would allow clients to invalidate their own cache entries.

A pleasant surprise in constructing the proofs for the protocol was that the proof could be based on the data for which the client received a callback first. That is, the proof rested on f being valid or v being valid. There is one exception, which does not occur in our

implementation. If a volume callback is obtained before a file callback, the client could lose the volume callback and still continue the run. A notion of hierarchy (i.e., x is “contained in” y) would help to switch the proof from one data type to the other cleanly.

Appendix B

Coda Internals

This chapter provides detail on the Coda client and server implementation and system interfaces necessary to understand the body of this dissertation. It is intended to be a supplement to the system overview given in Chapter 2.

B.1 Client Structure

Coda support on a client workstation consists of two components. The first component, called the *MiniCache* [123], is a small in-kernel module that implements the Sun Microsystems *Virtual File System (VFS) interface* [64], a standard system call intercept mechanism that allows multiple file systems to co-exist within a single Unix kernel. This interface is summarized in Table B.1. The second component is a much larger user-level cache manager called *Venus*. Although its functionality could be provided within the kernel for better performance, the user-level implementation is more portable and considerably easier to debug. The structure of a Coda client is illustrated in Figure 2.9.

An application system call involving a Coda object is directed by the VFS layer to the Coda VFS. If the information required is contained within the Coda VFS, the call is serviced without involving Venus and control returns to the application. Otherwise, the kernel contacts Venus by writing a message to a pseudo-device. Venus reads the request from the pseudo-device, and if remote access is necessary, contacts the Coda file servers using the RPC2 remote procedure call package [111]. When Venus completes processing the request, it writes a response on the pseudo-device, and control returns back through the kernel to the application process.

Operation	Description
<code>vfs_mount</code>	Mount a VFS.
<code>vfs_unmount</code>	Unmount a VFS.
<code>vfs_root</code>	Return the root vnode of a VFS.
<code>vfs_statfs</code>	Return file system information.
<code>vfs_sync</code>	Write out all cached information for a VFS.
<code>vfs_vget</code>	Return the vnode corresponding to a fid in the VFS.
<code>vn_open</code>	Perform the open protocol on a vnode.
<code>vn_close</code>	Perform the close protocol on a vnode.
<code>vn_rdwr</code>	Read or write a vnode.
<code>vn_ioctl</code>	Perform an ioctl on a vnode.
<code>vn_getattr</code>	Get attributes for a vnode.
<code>vn_setattr</code>	Set attributes for a vnode.
<code>vn_access</code>	Check access permissions for a vnode.
<code>vn_lookup</code>	Look up a component name in a directory vnode.
<code>vn_create</code>	Create a new file with the specified name in a directory vnode.
<code>vn_remove</code>	Remove a file in a directory vnode.
<code>vn_link</code>	Link a vnode to a target name in a target directory vnode.
<code>vn_rename</code>	Rename the file corresponding to a vnode.
<code>vn_mkdir</code>	Create a directory in a directory vnode.
<code>vn_rmdir</code>	Remove a directory in a directory vnode.
<code>vn_readdir</code>	Read entries from a directory vnode.
<code>vn_symlink</code>	Create a symbolic link in a directory vnode.
<code>vn_readlink</code>	Read a symbolic link vnode.
<code>vn_fsync</code>	Write out all cached information for a vnode.
<code>vn_inactive</code>	Indicate that a vnode is inactive and may be deallocated.

Table B.1: VFS and Vnode Interfaces

This table shows the VFS and Vnode interface operations supported by Coda. The operations correspond to the original interface described by Kleiman [64].

B.1.1 Coda MiniCache

The VFS interface separates system call execution into file system independent and dependent layers. It defines sets of operations on file systems through the VFS, and on files through the *virtual inode* (*vnode*). The file system independent layer of the VFS interface redirects operations to the appropriate file system implementation based on *vnode* type. The Coda MiniCache exports the operations in the VFS interface for Coda objects.

As Figure 2.9 shows, the MiniCache interacts with the user-level Venus process to service operations on Coda objects. The performance cost for this interaction can be high; for example, pathname translation involves a separate *vnode* operation for each pathname component. To reduce the number of kernel-Venus interactions, the MiniCache caches four kinds of information that allows it to satisfy common file system requests without contacting Venus:

- *Pathname translations.* The MiniCache retains successful translations of pathname components. This allows it to satisfy pathname lookup requests, as well as some access checking.
- *Open file handles.* When a file is opened, the MiniCache retains a pointer to the *vnode* of the local Unix file in Venus's cache. This allows read and write system calls to be handled by the local file system. The MiniCache notifies Venus when the file is closed.
- *File attributes.* The MiniCache caches file attributes to allow it to service the frequently used `stat` system call.
- *Symbolic links.* The MiniCache caches symbolic link contents to improve pathname translation performance.

The MiniCache has yielded performance results comparable to AFS-3, which has an in-kernel cache manager.

Because the MiniCache shares file system state with Venus, the state must be coherent. The MiniCache is updated after all calls forwarded to Venus. In addition, it provides an interface through which Venus may invalidate or replace MiniCache state, such as when a server breaks a callback. This interface is shown in Table B.2.

B.1.2 Venus

The primary responsibilities of Venus are to service user file system requests, maintain cache coherence while connected, and manage the cache within predefined resource limits. In addition, it must hoard data in anticipation of disconnection, log and reintegrate disconnected updates, detect diverging replicas and trigger their resolution or quarantine them for repair.

Venus is implemented as a multi-threaded process using a lightweight co-routine thread package called LWP [111]. Venus threads types are summarized in Table B.3. A *main* thread

Operation	Description	Usage
CFS_FLUSH	flush all cache entries	Venus startup, repair
CFS_PURGEUSER	flush all cache entries pertaining to a specific user	token expiration
CFS_ZAPFILE	invalidate attributes for the specified file	file callback
CFS_ZAPDIR	invalidate attributes for the specified directory, and flush cache entries for its children	directory callback
CFS_PURGEFID	flush cache entry for the specified fid. If it is a directory, flush cache entries for its children	inconsistent object
CFS_REPLACE	replace one fid in all cache entries with another	reintegration

Table B.2: MiniCache Interface

starts the program and acts as a dispatcher of requests from the kernel. A set of *worker* threads services these requests. Venus exports the callback interface, shown in Table B.4, to servers. The callback interface is used not only for callbacks, but for other server-to-client operations as well, such as backfetching during reintegration. A variable number of *callback server* threads handle requests on this interface. When Venus detects that replicas of an object are diverging, it creates a *resolver* thread to invoke resolution on the object. The *reintegrator* thread merges disconnected and weakly connected updates with servers. A slew of *daemon* threads perform various periodic housekeeping tasks, such as hoard walks, detection of server and communication failures, and data collection. The *mariner* thread implements a dynamic debugging facility. The *fcon workers* service requests on an interface that provides failure injection and slow network emulation. A separate *simulator mode* is provided for trace-driven simulation. The *socket listener* and *SFTP listener* respond to packets sent by the RPC and bulk transfer protocols, respectively. Finally, The *I/O manager* provides a mechanism through which LWPs can wait for requests using a thread-specific version of the `select` system call.

B.1.2.1 Cache Structure

The file cache is logically divided into a status cache and a data cache. Two different non-volatile storage types are used to store cached structures. The status cache contains file system *meta-data*, such as status information on objects, and symbolic links. Meta-data is kept in RVM. The data cache is kept on the client's local disk, in local UNIX files called *container*

Thread Name	Number	Description
Main	1	initialize Venus, dispatch messages
Worker	variable	service requests from kernel
Callback server	variable	process callback messages
Reintegrator	variable	reintegrate disconnected, weakly-connected updates
Resolver	variable	invoke resolution on diverging replicas
Cache daemon	1	garbage collect cache entries, recompute object priorities, enforce usage limits
HDB daemon	1	maintain hoard database, perform hoard walks
Probe daemon	1	determine if a server is reachable, topology management
VSG daemon	1	garbage collect VSG database
Volume daemon	1	garbage collect volume database, perform volume state transitions, trickle reintegration, update protocol, CML checkpoints, periodic messages
User daemon	1	check for token expiry
Recovery daemon	1	truncate, flush RVM log
Advice daemon	1	service advice monitor requests
Local repair daemon	1	notify user of pending local repairs
Vmon daemon	1	send data to Mond data collection facility
Mariner	1	debugging facility
Simulator	1	main thread in simulator mode
Fcon worker	2	service requests for network emulation package
Socket listener	1	process, dispatch incoming RPC packets
SFTP listener	1	process, dispatch incoming bulk transfer packets
I/O manager	1	manage I/O for LWPs

Table B.3: Venus Thread Types

This table describes the function of Venus LWPs. All threads except the last three are created by Venus; the remainder are created by the RPC2 run-time library.

Operation	Description
CallbackConnect	Called the first time a server contacts a client
Callback	Break the callback promise for an object, also used to determine if a client is reachable
CallbackFetch	Fetch file data from Venus during reintegration
CallbackReceivedStore	Early return from a <code>ViceStore</code> call

Table B.4: Callback Interface

This table shows the Coda server-to-client RPC interface. In the descriptions above, “object” refers to a file, directory, or symbolic link.

files. The number of slots in the cache is fixed at Venus initialization, as is the maximum cache size. The cache daemon ensures that the cache stays within its specified size.

Cache entries are represented by a data structure called the `fsoobj`. An `fsoobj` is a recoverable structure containing the object’s identification and status block. It includes a descriptor for the object’s data, if it is cached; information on cache priority; mount state, if appropriate; links to CML records and other state, if the object has been modified while disconnected; and synchronization variables. The file cache as a whole is called the *file system database (FSDB)*.

Venus also maintains a number of other kinds of persistent data. The *volume database (VDB)* contains volume entries, which in turn contain information on preallocated fids and client modify logs. Most persistent structures contain non-persistent fields. For example, volume entries contain the volume states illustrated in Figure 2.1. In addition, threads perform synchronization at the volume level; in particular, reintegration and resolution are volume-level operations. Other persistent structures include VLDB mappings and the HDB.

B.1.2.2 Management of Persistent Data

Venus requires persistence for cached data, because the client must be able to survive reboots, and a server may not always be available to help it reload cached state.¹ A cached object has multiple persistent structures associated with it. For example, a cached file consists of its `fsoobj` and container file. Because of this structure, Venus requires atomicity of updates. For example, appending data to a file changes the container file, the `fsoobj` (length of the file), and

¹The implementation assumes no media failures. To address media failures, the client could use disk mirroring or some other local fault tolerance mechanism.

the FSDB (cache space usage). Either all or none of these structures must be updated for the data to remain mutually consistent.

While it is possible to use local files for all persistent data, such an implementation is awkward for a number of reasons. First, the UNIX buffer cache performs writes asynchronously to hide disk latency from applications [70]. Writes may be delayed to amortize the cost of a disk write and take advantage of cancelling or overwrite behavior, and they may be reordered for more efficient writing to disk. Data is vulnerable until it is written to disk; if a crash occurs some writes (not necessarily the latest ones) may be lost. To store persistent data entirely in local files, Venus would have to employ some combination of the following techniques:

- make extensive use of the `fsync` system call, which forces buffered writes to disk,
- modify the kernel to recognize data dependencies and ensure that data is written out in the correct order,
- organize the disk layout of persistent data to avoid inconsistencies after crashes,
- implement recovery code that can detect and recover from inconsistencies in persistent data.

All of these techniques have either high performance cost, are complex to implement and difficult to verify, or lack generality. Instead, Venus uses a local transaction facility called RVM [116, 75] that provides failure atomicity and permanence of updates. RVM exports the abstraction of *recoverable virtual memory*, which allows an application to read and update recoverable storage much as it would other in-memory structures. Atomicity of updates is guaranteed as long as they occur within transactions. Crash recovery is handled entirely by RVM.

RVM is implemented as a library which is linked into applications; its interface is shown in Table B.5. Recoverable data is stored as *recoverable segments* on disk. An application maps regions of these segments into its virtual address using the `rvm_map` routine. The application may perform transactions on recoverable data by bracketing updates between `rvm_begin_transaction` and `rvm_end_transaction`, and indicating the addresses of data updated with `rvm_set_range`. RVM tracks the old and new values of updated data in *change records*. RVM *flushes* updates to disk by appending the change records to a disk log. If the transaction commits, RVM writes a *commit record* for the transaction. By default, RVM flushes a transaction to the log at commit time. However, there is a *no-flush* option that allows an application to batch flushing of changes to disk. No-flush transactions are buffered in memory until the next flush occurs. When the RVM log exceeds a threshold, RVM *truncates* it by applying the change records for committed transactions in the log to the recoverable segments. Because flushes and truncates may interfere with request processing, RVM exports `rvm_flush` and `rvm_truncate` calls to allow applications to manage their own disk writes.

Operation	Description
<code>rvm_initialize</code>	initialize library state
<code>rvm_terminate</code>	finalize library state and terminate interaction
<code>rvm_map</code>	map a region of a recoverable segment into the application's address space
<code>rvm_unmap</code>	unmap a previously mapped region
<code>rvm_begin_transaction</code>	begin a transaction
<code>rvm_set_range</code>	indicate addresses of data modified by a transaction
<code>rvm_end_transaction</code>	commit a transaction
<code>rvm_abort_transaction</code>	abort a transaction
<code>rvm_flush</code>	force log records for committed transactions to the RVM disk log
<code>rvm_truncate</code>	apply change records in the RVM log to recoverable segments and discard the records

Table B.5: RVM Library Interface

This table shows the main RVM library routines used by Coda. The top four routines are initialization and mapping operations, the middle four are transactional operations, and the last two are log operations. There are a few additional routines for setting options, collecting statistics, and so on. Details appear in the RVM manual [75].

Venus uses no-flush transactions to avoid the overhead of disk writes on every transaction, and schedules both RVM flushes and truncates to avoid delays during a user request. Flushes and truncates can impede other client activity because Venus threads are blocked in the meantime, and other client processes encounter contention for the disk. The use of no-flush transactions means that Venus offers *bounded persistence*, that is, updates are locally persistent only after some time period has passed. While connected, the bound is 600 seconds; there is no need for a tighter bound because updates are globally persistent once executed at the servers. While disconnected, the bound is 30 seconds, consistent with the bound offered by UNIX on container files. The recovery daemon performs RVM flushes when:

- the persistence time bound has passed since the last flush,
- the buffer space used by the no-flush transactions exceeds a threshold (64 KB by default),
- Venus has been idle with respect to user requests for some period of time (60 seconds by default),
- Venus receives a signal to shut down.

Log truncation typically takes an order of magnitude longer than a log flush. To avoid the automatic truncations performed by the RVM library during transaction commit and log flush, the recovery daemon triggers log truncation when:

- the log size exceeds a threshold (256 KB by default),
- Venus has been idle with respect to user requests for some period of time (60 seconds by default).

B.1.2.3 Request Processing

The following list outlines Venus request processing of common UNIX file system calls. Venus begins servicing a request when the kernel writes a message to the Coda pseudo-device.

1. **Read request message and dispatch worker.** The main thread awakens from the equivalent of a `select` system call on the pseudo-device and reads the message. If there are any worker threads available, the main thread dispatches a worker to process the request. Otherwise, it queues the message for the next available worker.
2. **Decode request message.** The worker thread decodes the message to determine the request type and input parameters. It then invokes a routine that implements the appropriate VFS operation.
3. **Validate arguments.** The worker thread validates the input parameters for the request. For example, a `creat` system call cannot create an object with a pathname of “/”.

4. **Enter the volume.** Certain operations require access guarantees at the volume level. For example, resolution requires exclusive access to the volume. In this step, the worker thread performs synchronization on the volume.
5. **Get objects.** Objects involved in the request must be cached and valid. The worker thread looks up the objects based on the fids in the request message, contacts the servers to fetch or validate them if necessary, and acquires locks. If the worker contacts the servers, it checks the status of the replicas and invokes resolution if it detects divergence.
6. **Perform semantic, protection checks.** The worker thread verifies the soundness of the operation, and checks that the user making the request has permission to do so. For example, the object of an `unlink` request must not be a directory, and the user must have delete permission for the parent directory. Venus performs protection checks, even though the server does also, for two reasons. First, while connected, Venus can filter out illegal requests without contacting the server. Second, while disconnected, Venus emulates the server by performing local protection checks.
7. **Invoke operation.** In this step the worker thread actually performs the operation. In the case of a connected update, the worker issues a Vice RPC to the AVSG and processes the responses.
8. **Put objects.** The worker thread releases locks on objects.
9. **Exit the volume.** Volume state transitions occur after all threads have exited the volume.
10. **Return to kernel.** The worker thread returns the result of the request and output parameters, if any, to the kernel by writing them in a message on the Coda pseudo-device. The worker then makes itself available other requests.

B.2 Server Structure

Server support for Coda consists of a set of user-level processes, the *Vice file server*, and *authentication server*, and either an *update server* or an *update client*. One server is designated the *System Control Machine (SCM)*, and runs an update server; all other servers run an update client. Most servers run all three components, but this configuration is not necessary. Figure 2.10 shows an example server configuration.

B.2.1 Vice File Server

The primary responsibilities of a Vice file server are to handle file system requests from Venus, break callbacks to Venus when objects are updated, and participate in the resolution protocol.

Operation	Description
ViceConnectFS	Begin dialogue with file server
ViceDisconnectFS	Terminate dialogue with file server
ViceFetch	Fetch status (and possibly data) for an object, establish a callback for it
ViceStore	Store status (and possibly data) for a file
ViceRemove	Remove a file or symbolic link
ViceCreate	Create a file
ViceRename	Rename an object
ViceSymLink	Create a symbolic link
ViceLink	Create a name for a pre-existing object
ViceMakeDir	Create a directory
ViceRemoveDir	Remove a directory
ViceGetRootVolume	Return the name of the root volume
ViceSetRootVolume	Set the name of the root volume
ViceNewConnection	Called the first time a client contacts a server
ViceGetVolumeStatus	Get volume status information
ViceSetVolumeStatus	Set volume status (e.g., quotas)
ViceGetTime	Get time of day at server, used to determine if a server is reachable
ViceGetStatistics	Get file server statistics (e.g., CPU utilization)
ViceGetVolumeInfo	Get volume location information
ViceEnableGroup	Enable an authentication group
ViceDisableGroup	Disable an authentication group
ViceCOP2	Update version vectors modified during update protocol
ViceResolve	Resolve diverging replicas of an object
ViceRepair	Manually resolve an object
ViceSetVV	Set the version vector of an object
ViceAllocFids	Allocate a range of fids
ViceValidateAttrs	Fetch attributes for an object, batch validate objects, establish callbacks for all valid objects
ViceGetVolVS	Return the version stamp of a volume, establish a callback for it
ViceValidateVols	Validate the version stamp of a volume
ViceReintegrate	Merge disconnected updates
ViceOpenReintHandle	Return a handle for a pre-reintegration file transfer
ViceQueryReintHandle	Get the status of a pre-reintegration file transfer
ViceSendReintFragment	Transfer part of a file for an upcoming reintegration
ViceCloseReintHandle	Reintegrate already-transferred file data

Table B.6: Vice Interface

This table shows the Coda client-to-server RPC interface currently used by Venus. In the descriptions above, “object” refers to a file, directory, or symbolic link. Calls from `ViceValidateAttrs` onwards were added since the original implementation. In addition, many original calls, in particular updates, have changed since then.

Thread Name	Number	Description
Vice worker	variable	process Vice file server requests
Resolution worker	2	process resolution requests from other servers
Voutil worker	2	process volume utility requests
Probe daemon	1	determine if a client is reachable, topology management
Resolution probe daemon	1	determine if a server is reachable, topology management
Smon daemon	1	send data to Mond data collection facility
Check daemon	1	check for shutdown and salvage requests
COP pending manager	1	maintain list of updates pending COP2 messages
Lock queue manager	1	detect deadlock on volume locks
Fcon worker	2	service requests for failure emulation package
Socket listener	1	process, dispatch incoming RPC2 packets
SFTP listener	1	process, dispatch incoming SFTP packets
I/O Manager	1	manage I/O for LWPs

Table B.7: File Server Thread Types

This table describes the function of file server LWPs. All threads except the last three are created by the server; the remainder are created by the RPC2 run-time library.

The Vice file server exports the Vice interface, shown in Table B.6. Like Venus, the file server is a multi-threaded user-level process. File server threads are summarized in Table B.7. The *Vice worker* threads service file system requests from Venii. The *resolution workers* service requests from other servers on the resolution subsystem. The *voutil workers* service volume administration requests, such as backup, and also provide some debugging support. A set of daemons performs periodic housekeeping tasks, such as failure detection for clients (Vice) and servers (resolution), deadlock detection, and data collection. The Fcon and RPC threads are as in Venus.

```
icreate(device, near_inode, volume, vnode, unique, dataversion)  
  
iopen(device, inode, flags)  
  
iread(device, inode, parentvol, offset, buffer, size)  
iwrite(device, inode, parentvol, offset, buffer, size)  
  
iinc(device, inode, parentvol)  
idec(device, inode, parentvol)
```

Table B.8: Server Inode Interface

This table shows the interface used by the Vice file server to store and manage file data. These calls are extensions to the UNIX API that export kernel inode management routines.

The `icreate` call creates a file on device *device* and returns its inode number. The *near_inode* field is a placement argument that is not used. The remaining arguments are written to spare fields in the inode.

The `iopen` call opens the file at *device*, *inode* for reading and/or writing, as specified by *flags*, and returns a file descriptor for it. Once the file descriptor is returned, the file may be closed as usual with the `close` system call.

The `iread` and `iwrite` calls attempt to read or write *size* bytes from the file at *device*, *inode*, starting at offset *offset*, and placing the data in *buffer*. The *parentvol* argument is used as a sanity check for the inode. The return value is the number of bytes read or written.

The `iinc` and `idec` calls increment or decrement the link count on the file at *device*, *inode*. The *parentvol* argument is used as a sanity check for the inode. The return value is an error code.

B.2.1.1 Object Representation

Like Venus, the server stores persistent data using a combination of RVM and local UNIX files. File and volume meta-data, contents of directories and symbolic links, and resolution logs are stored in RVM. File contents are stored in local UNIX container files. To avoid overhead from pathname translation, container files are not named in any directory. The server accesses container files directly by inode through a set of system call extensions, shown in Table B.8.² The inode number is stored in the server's status descriptor for the file, much like the container file mechanism in Venus.

The server must guarantee permanence of updates when a transaction commits.³ Since container files are stored in the UNIX file system, the server has additional recovery mechanisms to augment those provided by RVM. If an update changes file data, the new data is stored in another container file or *shadow inode*. If the transaction aborts, the server removes the shadow; otherwise, the server installs the shadow as the new file and removes the old container file. If the server crashes, updates to container files may not have been written to disk. The server recovers by *salvaging* the container files at startup.⁴ If a container file does not exist, the server creates one and marks the object in conflict, and if a container file is not referenced by any object the server garbage collects it. In this way the server ensures that the container files and RVM state are mutually consistent.

B.2.1.2 Request Processing

Server processing of Vice RPCs for most operations is as follows. Processing begins when a Vice worker thread receives a request from a client.

1. **Validate parameters.** The worker thread performs sanity checks on the request. It begins by verifying that the request came from a known client. In the case of a replicated operation, it verifies that the VSG number corresponds to a volume it stores. It then performs request-specific checks.
2. **Get objects.** In this step, the worker thread looks up or creates objects necessary for the request, and performs volume and object locking as appropriate.
3. **Check semantics.** Semantic checks fall into three categories: concurrency control, integrity checks, and protection checks. For concurrency control, the server verifies that

²The inode system call extensions are not necessary for functionality, only for performance. The objects could be stored in a UNIX directory just like Venus container files.

³Unlike Venus, the server does not use no-flush transactions.

⁴Since container files are not named in any directory, servers run a special version of the `fsck` utility that does not garbage collect them.

the object version information sent by the client matches its current state. The integrity check ensures that the operation is sound, for example, for an `unlink` request the target object must not be a directory. The protection check verifies that the user responsible for the request has the rights to perform it. The integrity and protection checks are essentially those performed by Venus, but because clients may be subverted the server must also perform them.

4. **Perform operation.** In this step, the worker thread breaks callbacks, performs bulk transfer of data, and sets output parameters for the RPC as appropriate.
5. **Put objects.** The worker thread updates relevant objects transactionally, and releases object and volume locks. In case of an error, it discards any changes made during the course of the request.

B.2.2 Authentication Server

The authentication server provides the means for establishing secure RPC connections between clients and servers. A user authenticates to Coda by running the `clog` program and typing in a password. The login program establishes a secure connection to the authentication server, which maintains a database of user and password information. If the user authenticates successfully, the authentication server returns a pair of tokens valid for 25 hours. Then `clog` passes them to Venus. Venus uses these tokens to create secure connections to servers on behalf of that user. An unauthenticated user may access Coda objects; in that case the connections between Venus and the servers are unauthenticated, and the user has access rights of the “anonymous system user”.

B.2.3 Update System

Certain system databases, such as the password database and the volume location database, are replicated on many servers and change relatively slowly. The update system keeps these databases consistent between servers. The SCM runs an update server; all other servers run update clients. Modifications to the database are permitted only at the SCM. Update clients poll the SCM to detect and install new versions of system databases.

Bibliography

- [1] ACCETTA, M., BARON, R. V., BOLOSKY, W., GOLUB, D. B., RASHID, R. F., TEVANIAN, JR., A., AND YOUNG, M. W. Mach: A New Kernel Foundation for UNIX Development. In *Proceedings of the Summer 1986 USENIX Conference* (Atlanta, GA, July 1986), pp. 93–113.
- [2] AIRSOFT, INC., CUPERTINO, CA. *AirSoft AirAccess 2.0: Mobile Networking Software*, June 1994.
- [3] APM LIMITED, UK. *The ANSA Reference Manual Release 01.00*, March 1989.
- [4] AUSTEIN, R. Synchronization Operations for Disconnected IMAP4 Clients. Work in Progress.
- [5] BACHMANN, D., HONEYMAN, P., AND HUSTON, L. The Rx Hex. In *Proceedings of the First IEEE Workshop on Services in Distributed and Networked Environments* (Prague, Czech Republic, June 1994), pp. 66–74. Also available as technical report 93-8, Center for Information Technology Integration (CITI), University of Michigan, November 1993.
- [6] BAKER, M. G., HARTMANN, J. H., KUPFER, M. D., SHIRRIFF, K. W., AND OUSTERHOUT, J. K. Measurement of a Distributed File System. In *Proceedings of the Thirteenth ACM Symposium on Operating Systems Principles* (October 1991), pp. 198–212.
- [7] BAKER, M. G., ZHAO, X., CHESHIRE, S., AND STONE, J. Supporting Mobility in MosquitoNet. In *Proceedings of the 1996 USENIX Technical Conference* (San Diego, CA, January 1996), USENIX Association, pp. 127 – 139.
- [8] BECK, M., BÖHME, H., DZIADZKA, M., KUNITZ, U., MAGNUS, R., AND VERWORNER, D. *LINUX Kernel Internals*. Addison Wesley Longman Limited, Harlow, England, 1996.
- [9] BERNERS-LEE, T., CAILLIAU, R., LUOTONEN, A., NIELSEN, H. F., AND SECRET, A. The World-Wide Web. *Communications of the ACM* 37, 8 (August 1994), 76–82.

- [10] BIRRELL, A., AND NELSON, B. Implementing Remote Procedure Calls. *ACM Transactions on Computer Systems* 2, 1 (February 1984), 39–59.
- [11] BIRRELL, A. D., AND NELSON, B. J. Implementing Remote Procedure Calls. *ACM Transactions on Computer Systems* 2, 1 (February 1984), 39–59.
- [12] BOLOT, J.-C. End-to-End Packet Delay and Loss Behavior in the Internet. In *Proceedings of the SIGCOMM '93 Conference on Communications Architectures, Protocols, and Applications* (San Francisco, CA, September 1993), pp. 289–298.
- [13] BOZMAN, G., GHANNAD, H., AND WEINBERGER, E. A Trace-Driven Study of CMS File References. *IBM Journal of Research and Development* 35, 5–6 (September–November 1991), 815–28.
- [14] BRADEN, R. Requirements for Internet Hosts – Communication Layers. In *Internet Requests for Comments*, R. Braden, Ed., RFC 1122. SRI International, Menlo Park, CA, October 1989.
- [15] BRADEN, R., CLARK, D., AND SHENKER, S. Integrated Services in the Internet Architecture: an Overview. In *Internet Requests for Comments*, RFC 1633. Network Working Group, July 1994.
- [16] BURROWS, M. *Efficient Data Sharing*. PhD thesis, University of Cambridge, December 1988.
- [17] BURROWS, M., ABADI, M., AND NEEDHAM, R. A Logic of Authentication. Tech. Rep. 39, DEC Systems Research Center, February 1989.
- [18] BURROWS, M., ABADI, M., AND NEEDHAM, R. A Logic of Authentication. *ACM Transactions on Computer Systems* 8, 1 (February 1990), 18–36.
- [19] CLARK, D. D., SHENKER, S., AND ZHANG, L. Supporting Real-Time Applications in an Integrated Services Packet Network: Architecture and Mechanism. In *Proceedings of the SIGCOMM '92 Conference on Communications Architectures and Protocols* (Baltimore, MD, August 1992).
- [20] CLARK, D. D., AND TENNENHOUSE, D. L. Architectural Considerations for a New Generation of Protocols. In *Proceedings of the SIGCOMM '90 Conference on Communications Architectures and Protocols* (Philadelphia, PA, September 1990).
- [21] CLARKE, E., GRUMBERG, O., HIRAISHI, H., JHA, S., LONG, D., MCMILLAN, K., AND NESS, L. Verification of the Futurebus+ Cache Coherence Protocol. Tech. Rep. CMU-CS-92-206, Carnegie Mellon University School of Computer Science, October 1992.

- [22] CORNSWEET, T. N. *Visual Perception*. Academic Press, 1971.
- [23] COULSON, G., BLAIR, G. S., AND ROBIN, P. Micro-kernel support for continuous media in distributed systems. *Computer Networks and ISDN Systems* 26, 10 (July 1994), 1323–1341.
- [24] COWAN, C., CEN, S., WALPOLE, J., AND PU, C. Adaptive Methods for Distributed Video Presentation. *ACM Computing Surveys* 27, 4 (December 1995), 580–583.
- [25] CRISPIN, M. R. Internet Message Access Protocol - Version 4 Rev. 1. Work in Progress.
- [26] CRISPIN, M. R. Distributed Electronic Mail Models in IMAP4. In *Internet Requests for Comments*, RFC 1733. Network Working Group, December 1994.
- [27] CROWCROFT, J., WANG, Z., SMITH, A., AND ADAMS, J. A Rough Comparison of the IETF and ATM Service Models. *IEEE Network* 9, 6 (November/December 1995), 12–16.
- [28] DATE, C. J. *An Introduction to Database Systems*, vol. II. Addison-Wesley Publishing Company, Reading, Massachusetts, 1983.
- [29] DAVIDSON, S. B. Optimism and Concurrency in Partitioned Distributed Database Systems. *ACM Transactions on Database Systems* 9, 3 (September 1984), 456–481.
- [30] DAVIES, N., BLAIR, G. S., CHEVERST, K., AND FRIDAY, A. A Network Emulator to Support the Development of Adaptive Applications. In *Proceedings of the Second USENIX Symposium on Mobile & Location-Independent Computing* (Ann Arbor, Michigan, April 1995), USENIX Association, pp. 47–55.
- [31] DEERING, S. Host Extensions for IP Multicasting. In *Internet Requests for Comments*, RFC 1112. Network Working Group, Stanford, CA, August 1989.
- [32] DOMINACH, R. F. Design reviews at a distance. *IEEE Spectrum* 31, 6 (June 1994), 39–40.
- [33] DOWNING, A. R., GREENBERG, I. B., AND PEHA, J. M. OSCAR: A System for Weak-Consistency Replication. In *Proceedings of the Workshop on Management of Replicated Data* (Houston, Texas, November 1990), IEEE Computer Society Technical Committee on Operating Systems and Application Environments (TCOS), pp. 26–30.
- [34] DRUSCHEL, P., AND PETERSON, L. L. Fbufs: A High-Bandwidth Cross-Domain Transfer Facility. In *Proceedings of the Fourteenth ACM Symposium on Operating Systems Principles* (Asheville, NC, December 1993), pp. 189–202.

- [35] EBLING, M. *Evaluating and Improving the Effectiveness of Caching for Availability*. PhD thesis, Department of Computer Science, Carnegie Mellon University, 1997 (in preparation).
- [36] EBLING, M. R. Evaluating and Improving the Effectiveness of Hoarding. Thesis proposal, Carnegie Mellon University, April 1993.
- [37] ECKHARDT, D., AND STEENKISTE, P. Measurement and Analysis of the Error Characteristics of an In-Building Wireless Network. In *Proceedings of the ACM SIGCOMM '96 Conference on Applications, Technologies, Architectures, and Protocols for Computer Communication* (Stanford University, CA, August 1996), pp. 243–254.
- [38] FERRARI, D., BANERJEA, A., AND ZHANG, H. Network support for multimedia: A discussion of the Tenet Approach. *Computer Networks and ISDN Systems* 26, 10 (July 1994), 1267–1280.
- [39] FLOYD, R. Short-Term File Reference Patterns in a UNIX Environment. Tech. Rep. TR 177, Department of Computer Science, University of Rochester, March 1986.
- [40] FORMAN, G. H., AND ZAHORJAN, J. The Challenges of Mobile Computing. *IEEE Computer* 27, 4 (April 1994).
- [41] FULTON, J., AND KANTARJIEV, C. K. An Update on Low Bandwidth X (LBX). Tech. Rep. CSL-93-2, Xerox Palo Alto Research Center, February 1993.
- [42] GOLUB, D., DEAN, R., FORIN, A., AND RASHID, R. UNIX as an Application Program. In *USENIX Summer Conference Proceedings* (Anaheim, CA, June 1990), USENIX Association.
- [43] GRAY, C. G., AND CHERITON, D. R. Leases: An Efficient Fault-Tolerant Mechanism for Distributed File Cache Consistency. In *The Twelfth ACM Symposium on Operating Systems Principles* (Dec. 1989), ACM, pp. 202–210.
- [44] GRAY, T. Message Access Protocols and Paradigms. Networks and Distributed Computing, University of Washington, <http://www.imap.org/imap.vs.pop.html>, September 1995.
- [45] GUY, R. G., HEIDEMANN, J. S., MAK, W., PAGE, T. W., POPEK, G. J., AND ROTHMEIER, D. Implementation of the Ficus Replicated File System. In *USENIX Summer Conference Proceedings* (Anaheim, CA, June 1990), USENIX Association, pp. 63–71.
- [46] HEIDEMANN, J. S., PAGE, T. W., GUY, R. S., AND POPEK, G. J. Primarily Disconnected Operation: Experiences with Ficus. In *Second Workshop on the Management of*

- Replicated Data* (Monterey, CA, November 1992), IEEE Computer Society Technical Committee on Operating Systems, pp. 2–5.
- [47] HISGEN, A., BIRRELL, A., MANN, T., SCHROEDER, M., AND SWART, G. Availability and Consistency Tradeoffs in the Echo Distributed File System. In *Proceedings of the Second Workshop on Workstation Operating Systems* (September 1989), pp. 49 – 53.
- [48] HONEYMAN, P., AND HUSTON, L. Communications and Consistency in Mobile File Systems. *IEEE Personal Communications* 2, 6 (December 1995), 44–48.
- [49] HOWARD, J. H., KAZAR, M. L., MENEES, S. G., NICHOLS, D. A., SATYANARAYANAN, M., SIDEBOTHAM, R. N., AND WEST, M. J. Scale and Performance in a Distributed File System. *ACM Transactions on Computer Systems* 6, 1 (February 1988), 51–81.
- [50] HUSTON, L. B., AND HONEYMAN, P. Disconnected Operation for AFS. In *Proceedings of the USENIX Symposium on Mobile & Location-Independent Computing* (Cambridge, Massachusetts, August 1993), USENIX Association, pp. 1–10.
- [51] HUSTON, L. B., AND HONEYMAN, P. Partially Connected Operation. In *Proceedings of the Second USENIX Symposium on Mobile & Location-Independent Computing* (Ann Arbor, Michigan, April 1995), USENIX Association, pp. 91–97.
- [52] JACOBSON, V. Congestion Avoidance and Control. In *Proceedings of the SIGCOMM '88 Symposium on Communications Architectures and Protocols* (Stanford, CA, August 1988), pp. 314–329.
- [53] JACOBSON, V. Compressing TCP/IP Headers for Low-Speed Serial Links. In *Internet Requests for Comments*, RFC 1144. SRI International, Menlo Park, CA, February 1990.
- [54] JACOBSON, V., BRADEN, R., AND BORMAN, D. TCP Extensions for High Performance. In *Internet Requests for Comments*, RFC 1323. SRI International, Menlo Park, CA, May 1992.
- [55] JAIN, R. *The Art of Computer Systems Performance Analysis: Techniques for Experimental Design, Measurement, Simulation, and Modeling*. John Wiley & Sons, Inc., New York, NY, 1991.
- [56] JOHNSON, D. B., AND MALTZ, D. A. Protocols for Adaptive Wireless and Mobile Networking. *IEEE Personal Communications* 3, 1 (February 1996), 34 – 42.
- [57] KARN, P., AND PARTRIDGE, C. Improving Round-Trip Time Estimates In Reliable Transport Protocols. *ACM Transactions on Computer Systems* 9, 4 (November 1991), 364–373.

- [58] KATZ, R. H. Adaptation and Mobility in Wireless Information Systems. *IEEE Personal Communications 1*, 1 (1994).
- [59] KAWELL JR., L., BECKHARDT, S., HALVORSEN, T., OZZIE, R., AND GREIF, I. Replicated Document Management in a Group Communication System. In *Groupware: Software for Computer-Supported Cooperative Work*. IEEE Computer Society Press, Los Alamitos, CA, 1992, pp. 226–235.
- [60] KAY, J., AND PASQUALE, J. The Importance of Non-Data Touching Processing Overheads in TCP/IP. In *Proceedings of the SIGCOMM '93 Conference on Communications Architectures, Protocols, and Applications* (San Francisco, CA, September 1993), pp. 259–268.
- [61] KING, A. *Inside Windows 95*. Microsoft Press, Redmond, Washington, 1994.
- [62] KISTLER, J. J. *Disconnected Operation in a Distributed File System*. PhD thesis, School of Computer Science, Carnegie Mellon University, April 1993.
- [63] KISTLER, J. J., AND SATYANARAYANAN, M. Disconnected Operation in the Coda File System. *ACM Transactions on Computer Systems 10*, 1 (February 1992), 3 – 25.
- [64] KLEIMAN, S. R. Vnodes: An Architecture for Multiple File System Types in Sun UNIX. In *USENIX Summer Conference Proceedings* (Atlanta, GA, June 1986), USENIX Association, pp. 238 – 247.
- [65] KLEINPASTE, K., STEENKISTE, P., AND ZILL, B. Software Support for Outboard Buffering and Checksumming. In *Proceedings of the SIGCOMM '95 Conference on Applications, Technologies, Architectures, and Protocols for Computer Communication* (Cambridge, MA, August 1995), pp. 87–98.
- [66] KUMAR, P. *Mitigating the Effects of Optimistic Replication in a Distributed File System*. PhD thesis, School of Computer Science, Carnegie Mellon University, December 1994.
- [67] KUMAR, P., AND SATYANARAYANAN, M. Log-Based Directory Resolution in the Coda File System. In *Proceedings of the Second International Conference on Parallel and Distributed Information Systems* (January 1993), pp. 202 – 213. Also available as technical report CMU-CS-91-164, School of Computer Science, Carnegie Mellon University.
- [68] KUMAR, P., AND SATYANARAYANAN, M. Flexible and Safe Resolution of File Conflicts. In *Proceedings of 1995 USENIX Conference* (New Orleans, LA, January 1995), USENIX Association.
- [69] LAMPSON, B. W. Hints for Computer System Design. In *Proceedings of the Ninth ACM Symposium on Operating Systems Principles* (Bretton Woods, NH, October 1983).

- [70] LEFFLER, S. J., MCKUSICK, M. K., KARELS, M. J., AND QUARTERMAN, J. S. *The Design and Implementation of the 4.3BSD UNIX Operating System*. Addison-Wesley Publishing Company, Reading, Massachusetts, 1989.
- [71] LILIEN, L. Quasi-Partitioning: A New Paradigm for Transaction Execution in Partitioned Distributed Database Systems. In *Proceedings of the Fifth International Conference on Data Engineering* (Los Angeles, CA, February 6-10 1989), pp. 546–553.
- [72] LU, Q. *Improving Data Consistency for Mobile File Access Using Isolation-Only Transactions*. PhD thesis, School of Computer Science, Carnegie Mellon University, May 1996.
- [73] LU, Q., AND SATYANARAYANAN, M. Improving Data Consistency in Mobile Computing Using Isolation-Only Transactions. In *Proceedings of the Fifth Workshop on Hot Topics in Operating Systems* (Orcas Island, WA, May 1995).
- [74] MANN, T., BIRRELL, A., HISGEN, A., JERIAN, C., AND SWART, G. A Coherent Distributed File Cache with Directory Write-Behind. *ACM Transactions on Computer Systems* 12, 2 (May 1994).
- [75] MASHBURN, H. M., AND SATYANARAYANAN, M. *RVM – Recoverable Virtual Memory*. School of Computer Science, Carnegie Mellon University, June 1994.
- [76] McMILLAN, K., AND SCHWALBE, J. Formal Verification of the Encore Gigamax Cache Consistency Protocol. In *Proceedings of the 1991 International Symposium on Shared Memory Multiprocessors* (April 1991).
- [77] MERCER, C. W., ZELENKA, J., AND RAJKUMAR, R. On Predictable Operating System Protocol Processing. Tech. Rep. CMU-CS-94-165, School of Computer Science, Carnegie Mellon University, May 1994.
- [78] MEYERS, J. G., AND ROSE, M. T. Post Office Protocol - Version 3. In *Internet Requests for Comments*, RFC 1939. Network Working Group, May 1996.
- [79] MILLS, D. L. Internet Delay Experiments. In *Internet Requests for Comments*, RFC 889. SRI International, Menlo Park, CA, December 1983.
- [80] MOELLER, M. Lotus Opens cc:Mail to Pagers. *PC Week* 11, 35 (September 1994), 39.
- [81] MOGUL, J. C. Efficient Use of Workstations for Passive Monitoring of Local Area Networks. In *Proceedings of the SIGCOMM '90 Symposium on Communications Architectures and Protocols* (Philadelphia, PA, September 1990), pp. 253–263.

- [82] MORRIS, J. H., SATYANARAYANAN, M., CONNER, M. H., HOWARD, J. H., ROSENTHAL, D. S., AND SMITH, F. D. Andrew: A Distributed Personal Computing Environment. *Communications of the ACM* 29, 3 (March 1986).
- [83] MULLENDER, S. Interprocess Communication. In *Distributed Systems*, S. Mullender, Ed., second ed. Addison-Wesley Publishing Company, Reading, MA, 1993, ch. 9, pp. 217–250.
- [84] MUMMERT, L., AND SATYANARAYANAN, M. Large Granularity Cache Coherence for Intermittent Connectivity. In *USENIX Summer Conference Proceedings* (Boston, MA, June 1994), USENIX Association, pp. 279 – 289.
- [85] MUMMERT, L., AND SATYANARAYANAN, M. Variable Granularity Cache Coherence. *Operating Systems Review* 28, 1 (January 1994).
- [86] MUMMERT, L., AND SATYANARAYANAN, M. Long Term Distributed File Reference Tracing: Implementation and Experience. *Software: Practice and Experience* 26, 6 (June 1996), 705–736. Also available as technical report CMU-CS-94-213, School of Computer Science, Carnegie Mellon University, November 1994.
- [87] NANCE, B. File Transfer on Steroids. *Byte* 20, 2 (February 1995), 129–130.
- [88] NEEDHAM, R., AND SCHROEDER, M. Using Encryption for Authentication in Large Networks of Computers. *Communications of the ACM* 21, 12 (December 1978), 993 – 998.
- [89] NELSON, M. N., WELCH, B. B., AND OUSTERHOUT, J. K. Caching in the Sprite Network File System. *ACM Transactions on Computer Systems* 6, 1 (February 1988), 134 – 154.
- [90] NOBLE, B. D., PRICE, M., AND SATYANARAYANAN, M. A Programming Interface for Application-Aware Adaptation in Mobile Computing. In *Proceedings of the Second USENIX Symposium on Mobile and Location-Independent Computing* (Ann Arbor, MI, April 1995), pp. 57 – 66. Also available in *Computing Systems*, the journal of the USENIX Association, Volume 8, Number 4, Fall 1995.
- [91] NOBLE, B. D., AND SATYANARAYANAN, M. An Empirical Study of a Highly Available File System. In *Proceedings of the 1994 ACM SIGMETRICS Conference on Measurement and Modeling of Computer Systems* (Nashville, TN, May 1994), pp. 138 – 149.
- [92] NOVELL CORPORATION. *NetWare User Manual*, 1993.
- [93] OFFICE OF COMPUTING & COMMUNICATIONS, UNIVERSITY OF WASHINGTON. *Pine Information Center*. <http://www.cac.washington.edu:1180/pine/>.

- [94] OUSTERHOUT, J. K. *Tcl and the Tk Toolkit*. Addison Wesley, 1994.
- [95] OUSTERHOUT, J. K., COSTA, H. D., HARRISON, D., KUNZE, J. A., KNUPFER, M., AND THOMPSON, J. G. A Trace-Driven Analysis of the UNIX 4.2 BSD File System. In *Proceedings of the Tenth ACM Symposium on Operating Systems Principles* (Orcas Island, Washington, December 1985), pp. 15 – 24.
- [96] PETERSON, J. L., AND SILBERSCHATZ, A. *Operating System Concepts*. Addison-Wesley Publishing Company, Reading, Massachusetts, 1983.
- [97] POPEK, G., WALKER, B., CHOW, J., EDWARDS, D., KLINE, C., RUDISIN, G., AND THIEL, G. LOCUS: A Network Transparent, High Reliability Distributed System. In *Proceedings of the Eighth Symposium on Operating System Principles* (Pacific Grove, CA, December 1981).
- [98] POSTEL, J. User Datagram Protocol. In *Internet Requests for Comments*, RFC 768. SRI International, Menlo Park, CA, August 1980.
- [99] POSTEL, J. Transmission Control Protocol. In *Internet Requests for Comments*, RFC 793. SRI International, Menlo Park, CA, September 1981.
- [100] POSTEL, J., AND REYNOLDS, J. File Transfer Protocol. In *Internet Requests for Comments*, RFC 959. Network Working Group, Information Sciences Institute, October 1985.
- [101] POSTEL, J. B. Simple Mail Transfer Protocol. In *Internet Requests for Comments*, RFC 821. Information Sciences Institute, University of Southern California, Marina del Rey, CA, August 1982.
- [102] PRUSKER, F. J., AND WOBBER, E. P. The Siphon: Managing Distant Replicated Repositories. In *Proceedings of the Workshop on Management of Replicated Data* (Houston, Texas, November 1990), IEEE Computer Society Technical Committee on Operating Systems and Application Environments (TCOS), pp. 44 – 47.
- [103] QUALCOMM INCORPORATED. *Eudora Macintosh User Manual*, 1996.
- [104] RANGANATHAN, M., ACHARYA, A., SHARMA, S., AND SALTZ, J. Network-aware Mobile Programs. Tech. Rep. CS-TR-3659, Department of Computer Science, University of Maryland, June 1996. To appear in the Proceedings of the 1997 USENIX Technical Conference.
- [105] REICHARD, K., AND JOHNSON, E. F. Broadway: Sound And X On The Net. *Unix Review* 14, 7 (June 1996), 69–70.

- [106] RODEHEFFER, T. L., AND SCHROEDER, M. D. Automatic reconfiguration in Autonet. In *Proceedings of 13th ACM Symposium on Operating Systems Principles* (Asilomar, Pacific Grove, CA, October 1991), Association for Computing Machinery SIGOPS, pp. 183–97.
- [107] SALTZER, J. H., REED, D. P., AND CLARK, D. D. End-to-end Arguments in System Design. *ACM Transactions on Computer Systems* 2, 4 (November 1984), 277–288.
- [108] SANDBERG, R., GOLDBERG, D., KLEIMAN, S., WALSH, D., AND LYON, B. Design and Implementation of the Sun Network File System. In *USENIX Summer Conference Proceedings* (June 1985), USENIX Association.
- [109] SANGHI, D., AGARWALA, A. K., GUDMUNDSSON, O., AND JAIN, B. N. Experimental Assessment of End-to-end Behavior on Internet. In *Proceedings of the IEEE INFO-COM '93 Conference on Computer Communications* (San Francisco, CA, March 1993), pp. 867–874.
- [110] SATYANARAYANAN, M. Integrating Security in a Large Distributed System. *ACM Transactions on Computer Systems* 7, 3 (August 1989), 247 – 280.
- [111] SATYANARAYANAN, M. *RPC2 User Guide and Reference Manual*. School of Computer Science, Carnegie Mellon University, Pittsburgh PA 15213, October 1991.
- [112] SATYANARAYANAN, M. Fundamental Challenges in Mobile Computing. In *Proceedings of the Fifteenth ACM Symposium on Principles of Distributed Computing* (Philadelphia, PA, May 1996). Also available as technical report CMU-CS-96-111, School of Computer Science, Carnegie Mellon University, February 1996.
- [113] SATYANARAYANAN, M., HOWARD, J. H., NICHOLS, D. A., SIDEBOTHAM, R. N., SPECTOR, A. Z., AND WEST, M. J. The ITC Distributed File System: Principles and Design. In *Proceedings of the Tenth ACM Symposium on Operating Systems Principles* (Orcas Island, Washington, December 1985), pp. 35–50.
- [114] SATYANARAYANAN, M., KISTLER, J. J., KUMAR, P., OKASAKI, M. E., SIEGEL, E. H., AND STEERE, D. C. Coda: A Highly Available File System for a Distributed Workstation Environment. *IEEE Transactions on Computers* 39, 4 (April 1990), 447 – 459.
- [115] SATYANARAYANAN, M., KISTLER, J. J., MUMMERT, L. B., EBLING, M. R., KUMAR, P., AND LU, Q. Experience with Disconnected Operation in a Mobile Environment. In *Proceedings of the USENIX Symposium on Mobile & Location Independent Computing* (Cambridge, Massachusetts, August 1993), pp. 11 – 28.

- [116] SATYANARAYANAN, M., MASHBURN, H. H., KUMAR, P., STEERE, D. C., AND KISTLER, J. J. Lightweight Recoverable Virtual Memory. *ACM Transactions on Computer Systems* 12, 1 (February 1994), 33 – 57. Corrigendum: **12**, (2), 165–172 (1994).
- [117] SATYANARAYANAN, M., AND SIEGEL, E. H. Parallel Communication in a Large Distributed Environment. *IEEE Transactions on Computers* 39, 3 (March 1990).
- [118] SHARMA, R., AND KESHAV, S. Signaling and Operating System Support for Native-Mode ATM Applications. In *Proceedings of the SIGCOMM '94 Conference on Communications Architectures, Protocols, and Applications* (London, UK, August/September 1994), pp. 149–157.
- [119] SHENG, S., CHANDRAKASAN, A., AND BRODERSEN, R. A Portable Multimedia Terminal. *IEEE Communications Magazine* 30, 12 (December 1992).
- [120] SHENKER, S., ZHANG, L., AND CLARK, D. D. Dynamics of a Congestion Control Algorithm. *Computer Communications Review* 20, 5 (October 1990), 30–39.
- [121] SIDEBOTHAM, R. N. Volumes: The Andrew File System Data Structuring Primitive. In *European Unix User Group Conference Proceedings* (August 1986). Also available as Technical Report CMU-ITC-053, Carnegie Mellon University, Information Technology Center.
- [122] STEERE, D., AND SATYANARAYANAN, M. Using Dynamic Sets to Overcome High I/O Latencies During Search. In *Proceedings of the Fifth Workshop on Hot Topics in Operating Systems* (Orcas Island, WA, May 1995).
- [123] STEERE, D. C., KISTLER, J. J., AND SATYANARAYANAN, M. Efficient User-Level Cache File Management on the Sun Vnode Interface. In *USENIX Summer Conference Proceedings* (Anaheim, CA, June 1990), USENIX Association, pp. 325 – 331.
- [124] STINSON, C. *Running Microsoft Windows 95*. Microsoft Press, Redmond, Washington, 1995.
- [125] TANENBAUM, A. S. *Computer Networks*, 2nd ed. Prentice Hall, Englewood Cliffs, NJ, 1989.
- [126] TERRY, D. B., THEIMER, M. M., PETERSEN, K., DEMERS, A. J., SPREITZER, M. J., AND HAUSER, C. H. Managing Update Conflicts in Bayou, a Weakly Connected Replicated Storage System. In *Proceedings of the Fifteenth ACM Symposium on Operating Systems Principles* (Copper Mountain Resort, CO, December 1995), pp. 172–183.

- [127] WANG, R. Y., AND ANDERSON, T. E. xFS: A Wide Area Mass Storage File System. In *Proceedings of the Fourth Workshop on Workstation Operating Systems* (Napa, California, October 1993), pp. 71 – 78.
- [128] WEISER, M. The Computer for the Twenty-First Century. *Scientific American* 265, 3 (September 1991), 94 – 104.
- [129] WELLING, G., AND BADRINATH, B. R. A Framework for Environment Aware Mobile Applications. Department of Computer Science, Rutgers University. Submitted for publication, 1996.
- [130] ZHANG, L., DEERING, S., ESTRIN, D., SHENKER, S., AND ZAPPALA, D. RSVP: A New Resource ReSerVation Protocol. *IEEE Network* 7, 5 (September 1993), 8 – 18.
- [131] ZHANG, L., SHENKER, S., AND CLARK, D. D. Observations on the Dynamics of a Congestion Control Algorithm: The Effects of Two-Way Traffic. In *Proceedings of the SIGCOMM '91 Symposium on Communications Architectures and Protocols* (Zurich, Switzerland, September 1991), pp. 133–147.