

## UNIT 1B

### A Brief History Of Computing

Electronic Computing (1940' s to the Present)

15110 Principles of Computing,  
Carnegie Mellon University - CORTINA

1

## Alan Turing



- Considered the “father” of modern computer science.
- Presented formalisms for the notions of computation and computability in the 1930' s.
- Worked at Bletchley Park in Great Britain during WWII to develop Colossus to help break the German Enigma Code.
- Developed the notion in 1950 of a test for machine intelligence now called the Turing Test.
- The Turing Award, the highest award in computing, is named in honor of Alan Turing.

15-105 Principles of Computation,  
Carnegie Mellon University - CORTINA

2

# ENIAC

## Electronic Numerical Integrator and Computer

- Collaboration between Moore School of Electrical Engineering at the University of Pennsylvania and the Ballistic Research Laboratory in Aberdeen, MD
  - Designed by John W. Mauchley and J. Presper Eckert
- In 1943, the Ordnance Dept. signs a contract for UPenn to develop an electronic computer to solve differential equations for ballistic trajectories
- Constructed completed in the fall of 1945 after WWII ends, and dedicated in February 1946.



from www.computer.org

# ENIAC

## Electronic Numerical Integrator and Computer

- Filled an entire room
  - 42 panels, each 9' X 2' X 1' , three on wheels
  - organized in a U shaped around the perimeter of a room with forced air cooling
- Weighed 30 tons
- Reportedly consumed 150-200 kW of power
- Contained a huge amount of parts:
  - approx. 19,000 vacuum tubes and 1,500 relays
  - over 100,000 resistors, capacitors and inductors
- Input and output via an IBM card reader and card punch

# ENIAC

## Electronic Numerical Integrator and Computer

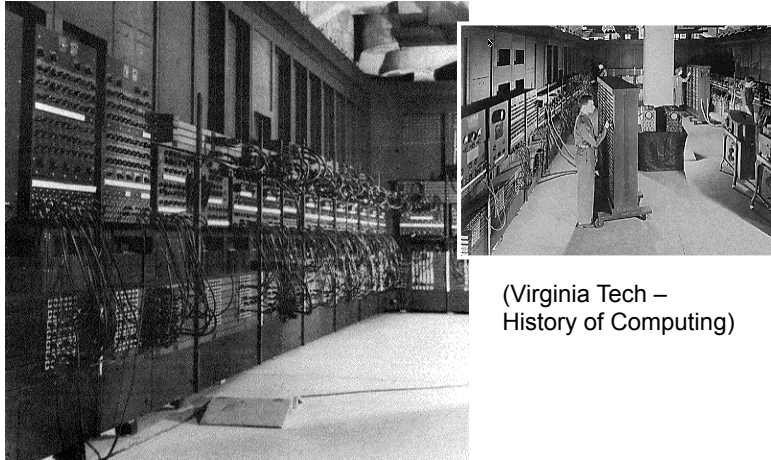

(Virginia Tech –  
History of Computing)

15-105 Principles of Computation,  
Carnegie Mellon University - CORTINA

5

## The first electronic computer?

- Patent filed for ENIAC in 1947 as first electronic computer
- In 1973, patent is ruled invalid
  - The inventor of the first electronic computer is John Atanasoff for the Atanasoff-Berry Computer
  - Outside of the U.S., Konrad Zuse of Germany is considered the inventor of the modern-day computer
    - Also designed the first programming language, Plankalkül (Plan Calculus) in 1945

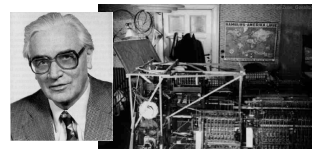

15-105 Principles of Computation,  
Carnegie Mellon University - CORTINA

6

## Stored Program Concept

- Stored-program concept is the fundamental principle of the ENIAC's successor, the EDVAC (Electronic Discrete Variable Automatic Computer)
- Instructions were stored in memory sequentially with their data
- Instructions were executed sequentially except where a conditional instruction would cause a jump to an instruction someplace other than the next instruction.

15-105 Principles of Computation,  
Carnegie Mellon University - CORTINA

7

## Stored Program Concept

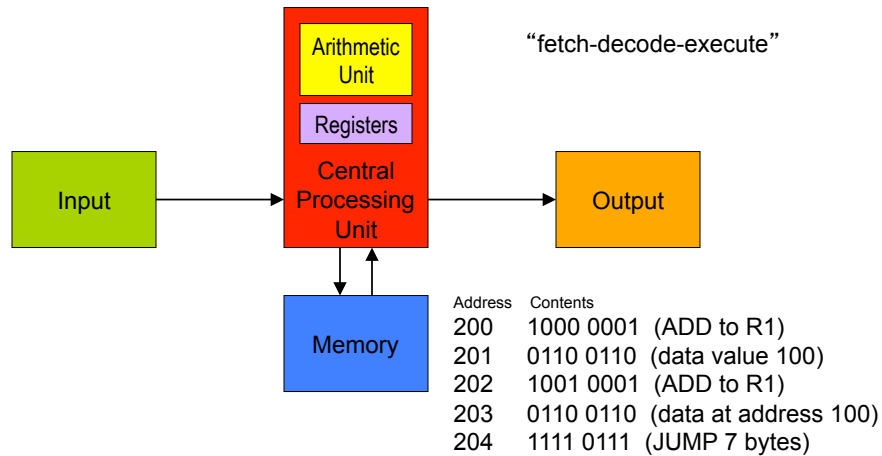

15-105 Principles of Computation,  
Carnegie Mellon University - CORTINA

8

## Stored Program Concept

- Mauchly and Eckert are generally credited with the idea of the stored-program
- BUT: John von Neumann publishes a draft report that describes the concept and earns the recognition as the inventor of the concept
  - “von Neumann architecture”
  - *A First Draft of a Report of the EDVAC* published in 1945
  - <http://www.wps.com/projects/EDVAC/>



von Neumann,  
Member of the Navy  
Bureau of Ordinance  
1941-1955

## UNIVAC and the First Compiled Programming Language

- UNIVAC I
  - Built by Remington Rand to compute 1950 U.S. census but completed in 1951
  - Used to predict the winner of the 1952 U.S. Presidential Election based on ~3.4M votes
- A-0 is a programming language for the UNIVAC I or II, using three-address code instructions for solving mathematical problems.
  - Example: ADD R1, R2, R3  
(Add the contents of R2 and R3 and put result in R1.)
- A-0 was the first language for which a compiler was developed, produced by a team led by Admiral Grace Hopper.



J. Presper Eckert and Walter Cronkite  
next to the UNIVAC in 1952  
(Center for the Study of Technology and Society)



Admiral Grace Hopper

# The Integrated Circuit



- Robert Noyce and Jack Kilby are credited with the invention of the integrated circuit (IC) or microchip.
  - Kilby wins Nobel Prize in Physics in 2000.
  - Robert Noyce co-founded Intel in 1968.
- By the mid 1970s, ICs contained tens of thousands of transistors per chip.
  - In 1970, Intel created the 1103--the first generally available DRAM chip.
  - Today, you would need more than 65,000 of them to put 8 MB of memory into a PC.

# Units of Memory

- Byte      B      8 bits (8b)
- Kilobyte    KB      1024 B      =  $2^{10}$  bytes       $\approx 10^3$  bytes
- Megabyte    MB      1024 KB      =  $2^{20}$  bytes       $\approx 10^6$  bytes
- Gigabyte    GB      1024 MB      =  $2^{30}$  bytes       $\approx 10^9$  bytes
- Terabyte    TB      1024 GB      =  $2^{40}$  bytes       $\approx 10^{12}$  bytes
- Petabyte    PB      1024 TB      =  $2^{50}$  bytes       $\approx 10^{15}$  bytes
- How many bytes can be stored in a 4GB flash drive?
- How many bytes/second is a 16Mbps cable modem connection?

## How Time Flies...



Commodore 64 (1982)  
40cm X 22 cm X 8 cm  
64KB of IC memory  
\$595



Apple iShuffle (2008)  
3cm X 3cm X 1cm  
2GB of flash memory  
\$49

## Moore's Law

- Gordon Moore co-founded Intel Corporation in 1968.
- Famous for his prediction on the growth of the semiconductor industry: Moore's Law
  - An empirical observation stating in effect that the complexity of integrated circuits doubles every 18 months. (“complexity” generally means number of transistors on a chip)



# Moore's Law

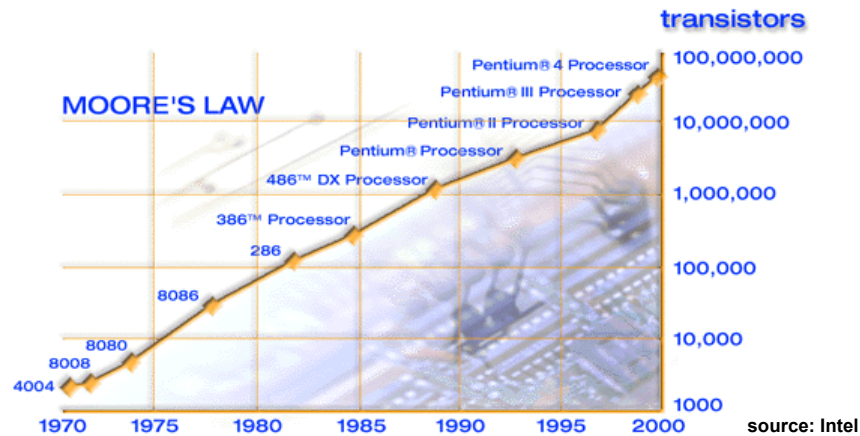

15-105 Principles of Computation,  
Carnegie Mellon University - CORTINA

15

# The GUI

## Graphical User Interface

- Concept born at SRI in the early 1960s
- Major development at Xerox PARC in late 70s
- Apple Macintosh, founded by Steve Jobs and his friend Steve Wozniak, introduced in 1984 with full GUI operating system
- Microsoft is founded by Bill Gates and Paul G. Allen with sales of Microsoft BASIC
  - develops its own window-based operating system soon afterwards based on Apple's design... many lawsuits follow
- Even IBM jumps into the fray with OS/2



15-105 Principles of Computation,  
Carnegie Mellon University - CORTINA

16



# The GUI

## Graphical User Interface

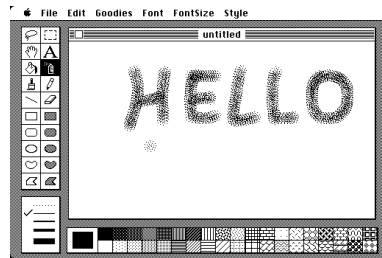

Macintosh OS

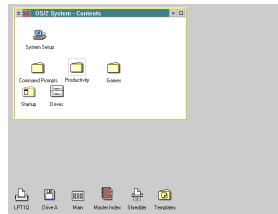

IBM OS/2

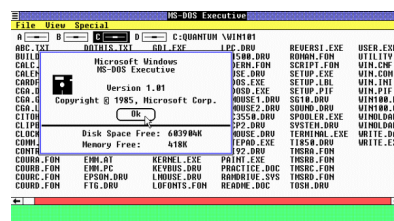

Microsoft Windows 1.0

# Input Devices

- The mouse was invented by Douglas Engelbart of Stanford Research Institute in 1963 after extensive usability testing.
  - He received a patent in Nov. 1970 for the "X-Y Position Indicator For A Display System".
  - He was the recipient of the 1997 ACM Turing Award. (<http://www.acm.org/awards/taward.html>)
- Ethernet was original developed as one of the many pioneering projects at Xerox PARC.
  - Invented between 1973-1976 by Robert Metcalfe and David Boggs



# The Birth of the Internet

- The earliest ideas of a global computer network were formulated by J.C.R. Licklider at MIT in 1962 in a series of memos discussing the "Galactic Network" concept.
- The Advanced Research Projects Agency Network (ARPANET) of the U.S. DoD was the world's first operational packet switching network.
  - Much of the work in computer development in the 1960s was spurred by the Space Race and the Cold War.
- In 1971, Ray Tomlinson of Bolt, Beranek, and Newman (BBN) wrote the first email program
- By the late 1980s, the DoD transferred operation of the network to NSF, and what is known as the "Internet" emerges.

## ARPANET 1971

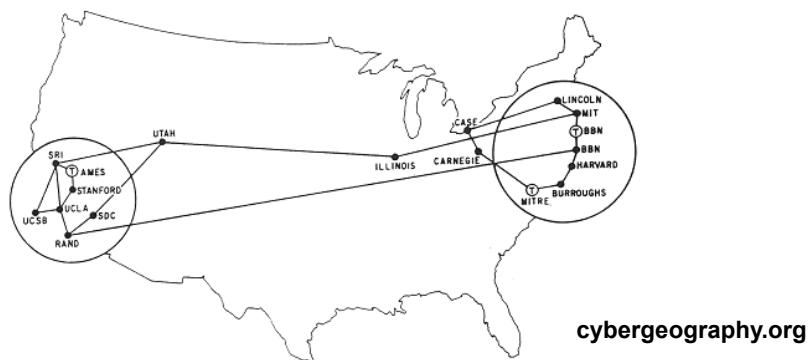

MAP 4 September 1971

# The World Wide Web

- Developed by Tim Berners-Lee of CERN (European Organization for Nuclear Research) - 1990
  - Used hypertext to mark up text documents so they could be searched and displayed by other users on the Internet
- Mosaic (1993): First Internet browser developed by a team at the National Center for Supercomputing Applications at the University of Illinois at Urbana-Champaign (NCSA-UIUC)
- Google (1998): World's most popular search engine company on the web launches from a pair of graduate students at Stanford University (Larry Page and Sergey Brin)
- Wikipedia (2001), Facebook (2004), YouTube (2005), Twitter (2006)



# Really?

- In 1981, Bill Gates is supposedly quoted as saying that how much computer memory “ought to be enough for anyone”?

