

15-213 Recitation: Bomb Lab

Your TAs

Feb 6th, 2023

Agenda

- Office Hours Etiquette
- Logistics
 - Bomb Lab Overview
 - Registers + Assembly Reminders
 - Introduction to GDB
 - GDB and Assembly Tips
 - Activity walkthroughs

REMINDER: Phase 3 is broken

- Phase 3 has several possible solutions
- Right now Autolab only recognizes one of them
- This may also be true for (some versions of) phases 4–6
- We will make an announcement when it's fixed
- We will clear explosions caused by this bug
- Recommend focusing on data lab for now

OH Etiquette

- **Good description:** “On phase 3. I’ve figured out that we need some string and an int, but I’m not sure how to figure out more info”
- **Bad description:** “bomb lab help”
 - (We know that already- that’s why you’re at OH. Write more details!)

What is Bomb Lab?

- An exercise in reading x86-64 assembly code.
- A chance to practice using GDB (a debugger).
- Why?
 - x86 assembly is low level machine code. Useful for understanding security exploits or tuning performance.
 - GDB can save you days of work in future labs (**Malloc**) and can be helpful long after you finish this class.

Downloading Your Bomb

- Here are some highlights of the write-up:
 - Bombs can only run on the shark machines. They fail if you run them locally or on another CMU server.
 - Each bomb is unique - if you download a second bomb, bad things can happen! Stick to only one bomb.
 - Bombs have six phases which get progressively harder.
 - Make sure to read the writeup for more tips and common mistakes you might make.

Detonating Your Bomb

- Blowing up your bomb automatically notifies Autolab
 - **Dr. Evil** deducts 0.5 points each time the bomb explodes.
 - It's very easy to prevent explosions using break points in GDB. More information on that soon.
- Inputting the correct string moves you to the next phase.
- Don't tamper with the bomb. Skipping or jumping between phases detonates the bomb.
- You have to solve the phases in order they are given. Finishing a phase also notifies Autolab automatically.

Understanding Your Bomb

- ***Dr. Evil*** may be evil, but he isn't cruel
- You can safely assume that functions do what their name implies
 - `phase_1()` implements the first phase
 - `read_six_numbers()` reads six numbers from the input, somehow
 - The details might be important
 - `explode_bomb()` probably makes the bomb explode
 - A good place to put a GDB breakpoint!

Understanding Your Bomb

- Functions with bizarre names are probably C library functions
 - `__isoc99_sscanf()`: another name for `sscanf()`
 - “isoc99” – ISO C standard, 1999 revision
 - `_exit@plt`: almost the same as `exit()`
 - there’s a difference between `_exit` and `exit`, but it’s not important for this lab
 - “@plt” has to do with dynamic linking, we’ll explain this later
- You *could* try to understand the assembly for these
 - But it’s going to be much easier to read the man page!
 - e.g. `$ man sscanf`

Caller Saved Registers

- **%rax**
 - Return value
 - Also caller-saved
 - Can be modified by procedure
- **%rdi, ..., %r9**
 - Arguments
 - Also caller-saved
 - Can be modified by procedure
- **%r10, %r11**
 - Caller-saved
 - Can be modified by procedure

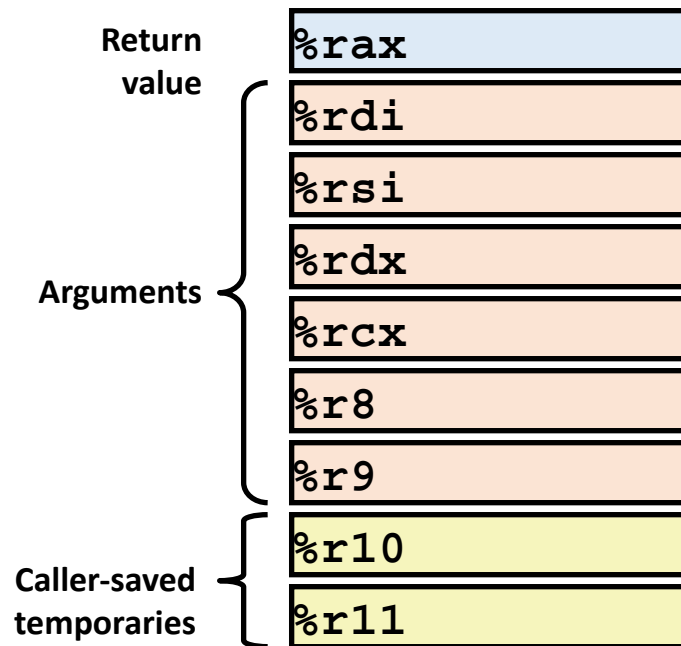

Callee Saved Registers

- **%rbx, %r12, %r13, %r14**
 - Callee-saved
 - Callee must save & restore
- **%rbp**
 - Callee-saved
 - Callee must save & restore
 - May be used as a frame pointer
 - Can mix & match
- **%rsp**
 - Stack pointer, special form of callee save
 - Restored to original value upon exit from procedure

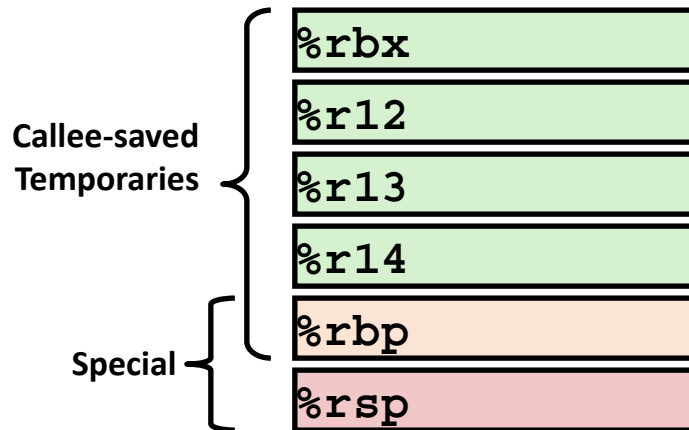

Most Important Registers

- `%rax`: return value
- `%rsp`: stack pointer
- `%rdi`: 1st argument
- `%rsi`: 2nd argument
- `%rdx`: 3rd argument
- `%rcx`: 4th argument
- `%r8`: 5th argument
- `%r9`: 6th argument

sscanf

- man sscanf
 - you are allowed to look up documentation of functions
 - man pages are your friend :)
- sscanf: string scan format
 - parses a string provided as an argument to the function

```
char *example_string = "123, 456";  
int a, b;  
sscanf(example_string, "%d, %d", &a, &b)
```

After this code snippet is run, $a = 123$ and $b = 456$

Assembly Reminders

- Operand Types
 - Immediate: \$0x400, \$-533 → a constant prefixed with \$
 - Register: %rax, %r12 → value in the register
 - Memory: (%rax) → memory at address given by register
- $D(Rb, Ri, S) = Mem[Reg[Rb] + S * Reg[Ri] + D]$
 - D: constant displacement
 - Rb: base register (any of the 16 registers)
 - Ri: index register (any except for %rsp)
 - S: scale (1, 2, 4, or 8)
 - \$100(%rax, %rsi, 2)

GDB

GDB is a powerful debugger-- let's you inspect your program as it's executing.

- You can open gdb by typing into the shell:
- `$ gdb`
- Type `gdb` and then a binary to specify which program to run
- `$ gdb <binary>`
- This is the notation we'll be using for the rest of the slides:
- `$ cd` // The command should be typed in the bash shell
- `(gdb) break` // The command should be typed in GDB

Helpful GDB Commands

Disassemble: displays assembly

```
int squareInt(int x) {  
    return x * x;  
}
```

(gdb) *disassemble squareInt*

Dump of assembler code for function squareInt:
0x000000000040091d <+0>: mov %edi,%eax
0x000000000040091f <+2>: imul %edi,%eax
0x0000000000400922 <+5>: retq
End of assembler dump.

** **disas != disa in gdb!** Be careful with these shortcuts on bomblab

Helpful GDB Commands

Breakpoints: stops execution of program when it reaches certain point

- *break function_name*: breaks once you call a specific function
- *break *0x...:* breaks when you execute instruction at a certain address
 - This version will only work if the bomb is running!
 - The address you want will change every time you restart the bomb!
 - Start with “break main”, then “run”, then check the address, then “break *0x...”
- *info b*: displays information about all breakpoints currently set
- *disable #*: disables breakpoint with id equal to #
 - Watch out! “disable” with no argument means disable *all* breakpoints
 - GDB “helpfully” interprets “d”, “di”, “dis”, etc. as short for “disable”
 - ... not “disassemble”, which may have been what you meant

Helpful GDB Commands

Navigating through assembly:

- *stepi*: moves one instruction forward, will step into functions encountered
- *nexti*: moves one instruction forward, skips over functions called
- *c*: continues execution until next breakpoint is hit

Text User Interface (TUI) mode

WARNING – do not use!

Although the TUI mode is very convenient, it has been known to accidentally set off student's bombs during Bomblab (but is fine for future labs like malloc).

The course staff is not responsible if your bomb goes off due to the TUI, and will not remove the explosion from Autolab.

What to do

- Don't understand what a big block of assembly does? **GDB**
- Need to figure out what's in a specific memory address? **GDB**
- Can't trace how 4 – 6 registers are changing over time? **GDB**
- Have no idea how to start the assignment? **Writeup**
- Need to know how to use certain GDB commands? **Writeup**
 - Also useful: <http://csapp.cs.cmu.edu/3e/docs/gdbnotes-x86-64.pdf>
- Don't know what an assembly instruction does? **Lecture slides**
- Confused about control flow or stack discipline? **Lecture slides**

Form Pairs

- One student needs a laptop
- SSH into a shark machine and type these commands:
- `$ wget http://www.cs.cmu.edu/~213/activities/rec4.tar`
- `$ tar xvpf rec4.tar`
- `$ cd rec4`
- `$ make`
- `$ gdb act1`

Activity Walkthroughs

Source code for Activity 1 (Abridged)

```
#include <stdio.h>
```

```
int main(int argc, char** argv) {  
    int ret = printf("%s\n", argv[argc-1]);  
    return ret;    // number of characters printed  
}
```

```
// Follow along on the handout!
```

Activity 1 trace

- (gdb) disassemble main // show the assembly instructions in main
- (gdb) print (char*) [0x4...] // hex code from <+14>
// prints a string
- Find the seemingly random \$0x... value in the assembly code
- Q: Does the printed value correspond to anything in the C code?
- (gdb) break main
- (gdb) run 15213
- (gdb) print argv[1] // Q: What does this print out?
- (gdb) continue
- (gdb) quit // exit GDB; agree to kill the running process

Activity 3

- Activity 3 has a Bomb Lab feel to it. It will print out “good args!” if you type in the right numbers into the command line. Use GDB to find what numbers to use, and if you get stuck, look at the handout.
- `$ cat act3.c` `// display the source code of act3`
- `$ gdb act3`
- Q. Which register holds the return value from a function?
- (Hint: Use `disassemble` in `main` and look at what register is used right after the function call to compare)

Questions?

- Remember, **bomb lab** is due Thursday Feb. 9th!
- Read the write up!
- Ask on piazza or go to prof OH for longer questions
- Narrow down your focus for OH
- Good luck :)

Appendix

- GDB help
- Assembly help
- Text User Interface (TUI)
- Problem walkthroughs

Basic GDB tips

- Many commands have shortcuts. Dissassemble → `disas`. Disable → `dis`
 - Do not mix these up! Disable will disable all your breakpoints, which may cause you to blow up your bomb.
- `(gdb) print [any valid C expression]`
 - This can be used to study any kind of local variable or memory location
 - Use casting to get the right type (e.g. `print *(long *)ptr`)
- `(gdb) x [some format specifier] [some memory address]`
 - Examines memory. See the handout for more information. Same as `print *(addr)`, but more convenient.
- `(gdb) set disassemble-next-line on`
`(gdb) show disassemble-next-line`
 - Shows the next assembly instruction after each step instruction
- `(gdb) info registers` Shows the values of the registers
- `(gdb) info breakpoints` Shows all current breakpoints
- `(gdb) quit` Exits gdb

Quick Assembly Info

- `$rdi` holds the first argument to a function call, `$rsi` holds the second argument, and `$rax` will hold the return value of the function call.
- Many functions start with “push `%rbx`” and end with “pop `%rbx`”. Long story short, this is because `%rbx` is “callee-saved”.
- The stack is often used to hold local variables
 - Addresses in the stack are usually in the `0x7fffffff...` range
- Know how `$rax` is related to `$eax` and `$al`.
- Most cryptic function calls you’ll see (e.g. `callq ... <_exit@plt>`) are calls to C library functions. If necessary, use the Unix man pages to figure out what the functions do.

Source code for Activity 2 (Abridged)

```
#include <string.h>

int stc(char*, char*); // Defined in a separate assembly file
int main(int argc, char** argv) {
    int ret = stc("15213", argv[argc-1]);
    argv[0] = '\0';    // Forces gcc to generate a callq instead of jmp
    return ret;
}

// Follow along on the handout!
```

Activity 2 trace

- `$ gdb act2`
- `(gdb) break main`
- `(gdb) disas main`
- `(gdb) run`
- `(gdb) print /x $rsi` // '/x' means print in hexadecimal
- `(gdb) print /x $rdi`
- Q. RDI and RSI are registers that pass the first two arguments. Looking at their values, which is the first argument to main (the 'argc' argument)? Why?

- `(gdb) disassemble main` // note the call to stc at <+17>
- `(gdb) break stc` // main calls the stc function, so we'll study that function too
- `(gdb) continue`
- Q. How could you view the arguments that have been passed to stc?
 - Try both of these: `"print /x $rdi"`, `"x /s $rdi"`

Activity 2 trace

- (gdb) run 18213 // gdb will ask if you want to restart; choose yes
- (gdb) continue // Q. Which function is in execution now?
- (gdb) disassemble // note the “=>” on the left side
- (gdb) nexti // step through a single x86 instruction
- (gdb) // just press enter 3 to 4 times
 - GDB will repeat your previous instruction. Useful for single-stepping.
- (gdb) disassemble
- Q. Now where are the “=>” characters printed?
- (gdb) quit

Activity 3 trace

- (gdb) run 5208 10000
- About to run `push %rbx`
- `$rdi = 5208`
- `$rsi = 10000`
- `$rbx = [$rbx from somewhere else]`
- `$rax = [garbage value]`

- Stack:
[some old stack items]

- (gdb) nexti

```
push    %rbx
mov     %rdi,%rbx
add     $0x5,%rbx
add     %rsi,%rbx
cmp     $0x3b6d,%rbx
sete    %al
movzbl %al,%rax
pop     %rbx
retq
```

Activity 3 trace

- About to run `mov %rdi, %rbx`
- `$rdi = 5208`
- `$rsi = 10000`
- `$rbx = [$rbx from somewhere else]`
- `$rax = [garbage value]`

- Stack:
[`$rbx from somewhere else`]
[some old stack items]

- (gdb) nexti

```
push    %rbx
mov     %rdi,%rbx
add     $0x5,%rbx
add     %rsi,%rbx
cmp     $0x3b6d,%rbx
sete    %al
movzbl %al,%rax
pop     %rbx
retq
```

Activity 3 trace

- About to run `add $0x5, %rbx`
- `$rdi = 5208`
- `$rsi = 10000`
- `$rbx = 5208`
- `$rax = [garbage value]`

- Stack:
[`$rbx` from somewhere else]
[some old stack items]

- (gdb) nexti

```
push    %rbx
mov     %rdi,%rbx
add     $0x5,%rbx
add     %rsi,%rbx
cmp     $0x3b6d,%rbx
sete    %al
movzbl %al,%rax
pop     %rbx
retq
```

Activity 3 trace

- About to run `add %rsi, %rbx`
- `$rdi = 5208`
- `$rsi = 10000`
- `$rbx = 5213`
- `$rax = [garbage value]`

- Stack:
[`$rbx` from somewhere else]
[some old stack items]

- (gdb) nexti

```
push    %rbx
mov     %rdi,%rbx
add     $0x5,%rbx
add     %rsi,%rbx
cmp     $0x3b6d,%rbx
sete    %al
movzbl %al,%rax
pop     %rbx
retq
```

Activity 3 trace

- About to run `cmp 0x3b6d, %rbx`
& other instructions
- `$rdi = 5208`
- `$rsi = 10000`
- `$rbx = 15213 (= 0x3b6d)`
- `$rax = [garbage value]`
- Stack:
[`$rbx` from somewhere else]
[some old stack items]
- (gdb) nexti
- (gdb) nexti
- (gdb) nexti

```
push    %rbx
mov     %rdi,%rbx
add     $0x5,%rbx
add     %rsi,%rbx
cmp     $0x3b6d,%rbx
sete    %al
movzbl %al,%rax
pop     %rbx
retq
```

Activity 3 trace

- About to run `pop %rbx`
- `$rdi = 5208`
- `$rsi = 10000`
- `$rbx = 15213 = 0x3b6d`
- `$rax = 1`

- Stack:
[`$rbx` from somewhere else]
[some old stack items]

- (gdb) nexti

```
push    %rbx
mov     %rdi,%rbx
add     $0x5,%rbx
add     %rsi,%rbx
cmp     $0x3b6d,%rbx
sete   %al
movzbl %al,%rax
pop     %rbx
retq
```

Activity 3 trace

- About to run `retq`
- `$rdi = 5208`
- `$rsi = 10000`
- `$rbx = [$rbx from somewhere else]`
- `$rax = 1`

- Stack:

[some old stack items]

```
push    %rbx
mov     %rdi,%rbx
add     $0x5,%rbx
add     %rsi,%rbx
cmp     $0x3b6d,%rbx
sete    %al
movzbl %al,%rax
pop     %rbx
retq
```

Activity 4

Use what you have learned to get `act4` to print “Finish.”

The source code is available in `act4.c` if you get stuck. Also, you can ask TAs for help understanding the assembly code.

Activity 4 trace

- \$ gdb act4
- (gdb) disassemble main
- Note 3 functions called: strtouq, compute, fwrite
- If you look at the strtouq man page:
 - convert a string to a long integer
- Fwrite is probably a print function. Print values stored into \$rdi immediately before calling fwrite
 - Why are they put into \$rdi?
- Look at addresses at <+60> and <+94>, may be different when you do this
- (gdb) x /s 0x4942c0
 - “Please rerun with a positive number argument\n”
- (gdb) x /s 0x4942f0
 - “Argument was not a positive integer

```
(gdb) disassemble main
Dump of assembler code for function main:
0x00000000400af0 <+0>:      sub    $0x8,%rsp
0x00000000400af4 <+4>:      cmp    $0x1,%edi
0x00000000400af7 <+7>:      je     0x400b1b <main+43>
0x00000000400af9 <+9>:      mov    0x8(%rsi),%rdi
0x00000000400afd <+13>:     mov    $0xa,%edx
0x00000000400b02 <+18>:     xor    %esi,%esi
0x00000000400b04 <+20>:     callq 0x401e80 <strtouq>
0x00000000400b09 <+25>:     test   %eax,%eax
0x00000000400b0b <+27>:     js     0x400b3d <main+77>
0x00000000400b0d <+29>:     mov    %eax,%edi
0x00000000400b0f <+31>:     callq 0x400f20 <compute>
0x00000000400b14 <+36>:     xor    %eax,%eax
0x00000000400b16 <+38>:     add   $0x8,%rsp
0x00000000400b1a <+42>:     retq
0x00000000400b1b <+43>:     mov    0x2bcc46(%rip),%rcx      # 0x6bd768 <stderr>
0x00000000400b22 <+50>:     mov    $0x2d,%edx
0x00000000400b27 <+55>:     mov    $0x1,%esi
0x00000000400b2c <+60>:     mov    $0x4942c0,%edi
0x00000000400b31 <+65>:     callq 0x4025b0 <fwrite>
0x00000000400b36 <+70>:     mov    $0x1,%eax
0x00000000400b3b <+75>:     jmp   0x400b16 <main+38>
0x00000000400b3d <+77>:     mov    0x2bcc24(%rip),%rcx      # 0x6bd768 <stderr>
0x00000000400b44 <+84>:     mov    $0x24,%edx
0x00000000400b49 <+89>:     mov    $0x1,%esi
0x00000000400b4e <+94>:     mov    $0x4942f0,%edi
0x00000000400b53 <+99>:     callq 0x4025b0 <fwrite>
0x00000000400b58 <+104>:    mov    $0x1,%eax
0x00000000400b5d <+109>:    jmp   0x400b16 <main+38>
End of assembler dump.
```

Activity 4 trace

- (gdb) disassemble compute
- We want it to print “Finish”. Note that the code jumps to <puts> at <+85>. Print the value stored into \$rdi immediately before <+80>
- (gdb) x /s 0x494290
 - "Finish"
- Want to get to either <+77> or <+80>
 - What happens if we get to <+75>?
- Because of <+75>, we know we have to jump to get to the puts jump at <+85>

```
(gdb) disassemble compute
Dump of assembler code for function compute:
   0x0000000000400f20 <+0>:   lea    (%rdi,%rdi,2),%eax
   0x0000000000400f23 <+3>:   mov    %eax,%edx
   0x0000000000400f25 <+5>:   and    $0xf,%edx
   0x0000000000400f28 <+8>:   nopl  0x0(%rax,%rax,1)
   0x0000000000400f30 <+16>:  cmp    $0x4,%edx
   0x0000000000400f33 <+19>:  ja     0x400f53 <compute+51>
   0x0000000000400f35 <+21>:  jmpq   *0x494298(,%rdx,8)
   0x0000000000400f3c <+28>:  nopl  0x0(%rax)
   0x0000000000400f40 <+32>:  and    $0x1,%eax
   0x0000000000400f43 <+35>:  mov    %eax,%edx
   0x0000000000400f45 <+37>:  jmp    0x400f30 <compute+16>
   0x0000000000400f47 <+39>:  nopw  0x0(%rax,%rax,1)
   0x0000000000400f50 <+48>:  sar    $0x2,%eax
   0x0000000000400f53 <+51>:  mov    %eax,%edx
   0x0000000000400f55 <+53>:  and    $0xf,%edx
   0x0000000000400f58 <+56>:  test   %eax,%eax
   0x0000000000400f5a <+58>:  jns    0x400f30 <compute+16>
   0x0000000000400f5c <+60>:  repz  retq
   0x0000000000400f5e <+62>:  xchg  %ax,%ax
   0x0000000000400f60 <+64>:  add    %eax,%eax
   0x0000000000400f62 <+66>:  jmp    0x400f53 <compute+51>
   0x0000000000400f64 <+68>:  nopl  0x0(%rax)
   0x0000000000400f68 <+72>:  sub    $0x1,%eax
   0x0000000000400f6b <+75>:  jmp    0x400f53 <compute+51>
   0x0000000000400f6d <+77>:  nopl  (%rax)
   0x0000000000400f70 <+80>:  mov    $0x494290,%edi
   0x0000000000400f75 <+85>:  jmpq   0x4027d0 <puts>
End of assembler dump.
```

Activity 4 trace

- There are 7 jumps. 3 to <+51>, 2 to <+16>, 1 to <puts>, and then:
 - `jmpq *0x494298(,%rdx,8)`
 - Should jump to address `*0x494298 + 8 * $rdx`
 - Note, may be different when you do this
- `(gdb) x /x *0x494298`
 - `0x400f70 <compute+80>`
- The only way this get us to where we want to go is if `$rdx = 0`.

```
(gdb) disassemble compute
Dump of assembler code for function compute:
   0x0000000000400f20 <+0>:   lea    (%rdi,%rdi,2),%eax
   0x0000000000400f23 <+3>:   mov    %eax,%edx
   0x0000000000400f25 <+5>:   and    $0xf,%edx
   0x0000000000400f28 <+8>:   nopl  0x0(%rax,%rax,1)
   0x0000000000400f30 <+16>:  cmp    $0x4,%edx
   0x0000000000400f33 <+19>:  ja     0x400f53 <compute+51>
   0x0000000000400f35 <+21>:  jmpq   *0x494298(,%rdx,8)
   0x0000000000400f3c <+28>:  nopl  0x0(%rax)
   0x0000000000400f40 <+32>:  and    $0x1,%eax
   0x0000000000400f43 <+35>:  mov    %eax,%edx
   0x0000000000400f45 <+37>:  jmp    0x400f30 <compute+16>
   0x0000000000400f47 <+39>:  nopw  0x0(%rax,%rax,1)
   0x0000000000400f50 <+48>:  sar    $0x2,%eax
   0x0000000000400f53 <+51>:  mov    %eax,%edx
   0x0000000000400f55 <+53>:  and    $0xf,%edx
   0x0000000000400f58 <+56>:  test   %eax,%eax
   0x0000000000400f5a <+58>:  jns    0x400f30 <compute+16>
   0x0000000000400f5c <+60>:  repz  retq
   0x0000000000400f5e <+62>:  xchg  %ax,%ax
   0x0000000000400f60 <+64>:  add    %eax,%eax
   0x0000000000400f62 <+66>:  jmp    0x400f53 <compute+51>
   0x0000000000400f64 <+68>:  nopl  0x0(%rax)
   0x0000000000400f68 <+72>:  sub    $0x1,%eax
   0x0000000000400f6b <+75>:  jmp    0x400f53 <compute+51>
   0x0000000000400f6d <+77>:  nopl  (%rax)
   0x0000000000400f70 <+80>:  mov    $0x494290,%edi
   0x0000000000400f75 <+85>:  jmpq   0x4027d0 <puts>
End of assembler dump.
```

Activity 4 trace

- Working backwards from <+21> with $\$rdx = 0$
- `cmp $0x4, %edx`
 - `ja` will jump to <+51> if $4 > \$edx$. Let's try $\$edx = 0$
- Want $\$edx = 0$. Thus from <+3> want $\$eax = 0$
- `lea (%rdi,%rdi,2),%eax`
 - Does $\$eax = \$rdi + 2 * \$rdi = 3 * \rdi
 - We want $\$edx = \$eax = 0$, so $\$rdi = 0$
- Since the input $\$rdi = 0$, let's run with 0.
- (gdb) run 0
 - What happens?

```
(gdb) disassemble compute
Dump of assembler code for function compute:
   0x0000000000400f20 <+0>:   lea    (%rdi,%rdi,2),%eax
   0x0000000000400f23 <+3>:   mov    %eax,%edx
   0x0000000000400f25 <+5>:   and    $0xf,%edx
   0x0000000000400f28 <+8>:   nopl  0x0(%rax,%rax,1)
   0x0000000000400f30 <+16>:  cmp    $0x4,%edx
   0x0000000000400f33 <+19>:  ja     0x400f53 <compute+51>
   0x0000000000400f35 <+21>:  jmpq   *0x494298(,%rdx,8)
   0x0000000000400f3c <+28>:  nopl  0x0(%rax)
   0x0000000000400f40 <+32>:  and    $0x1,%eax
   0x0000000000400f43 <+35>:  mov    %eax,%edx
   0x0000000000400f45 <+37>:  jmp    0x400f30 <compute+16>
   0x0000000000400f47 <+39>:  nopw  0x0(%rax,%rax,1)
   0x0000000000400f50 <+48>:  sar    $0x2,%eax
   0x0000000000400f53 <+51>:  mov    %eax,%edx
   0x0000000000400f55 <+53>:  and    $0xf,%edx
   0x0000000000400f58 <+56>:  test   %eax,%eax
   0x0000000000400f5a <+58>:  jns   0x400f30 <compute+16>
   0x0000000000400f5c <+60>:  repz  retq
   0x0000000000400f5e <+62>:  xchg  %ax,%ax
   0x0000000000400f60 <+64>:  add   %eax,%eax
   0x0000000000400f62 <+66>:  jmp   0x400f53 <compute+51>
   0x0000000000400f64 <+68>:  nopl  0x0(%rax)
   0x0000000000400f68 <+72>:  sub   $0x1,%eax
   0x0000000000400f6b <+75>:  jmp   0x400f53 <compute+51>
   0x0000000000400f6d <+77>:  nopl  (%rax)
   0x0000000000400f70 <+80>:  mov   $0x494290,%edi
   0x0000000000400f75 <+85>:  jmpq  0x4027d0 <puts>
End of assembler dump.
```

Activity 4 trace

- Compare the code to the assembly. Does it do what you expected?
- What do the jump statements to <+16> and <+51> correspond to?
- Working backwards like this could be helpful in bomb lab.

```
(gdb) disassemble compute
Dump of assembler code for function compute:
   0x0000000000400f20 <+0>:   lea    (%rdi,%rdi,2),%eax
   0x0000000000400f23 <+3>:   mov    %eax,%edx
   0x0000000000400f25 <+5>:   and    $0xf,%edx
   0x0000000000400f28 <+8>:   nopl  0x0(%rax,%rax,1)
   0x0000000000400f30 <+16>:  cmp    $0x4,%edx
   0x0000000000400f33 <+19>:  ja     0x400f53 <compute+51>
   0x0000000000400f35 <+21>:  jmpq   *0x494298(,%rdx,8)
   0x0000000000400f3c <+28>:  nopl  0x0(%rax)
   0x0000000000400f40 <+32>:  and    $0x1,%eax
   0x0000000000400f43 <+35>:  mov    %eax,%edx
   0x0000000000400f45 <+37>:  jmp    0x400f30 <compute+16>
   0x0000000000400f47 <+39>:  nopw  0x0(%rax,%rax,1)
   0x0000000000400f50 <+48>:  sar    $0x2,%eax
   0x0000000000400f53 <+51>:  mov    %eax,%edx
   0x0000000000400f55 <+53>:  and    $0xf,%edx
   0x0000000000400f58 <+56>:  test   %eax,%eax
   0x0000000000400f5a <+58>:  jns    0x400f30 <compute+16>
   0x0000000000400f5c <+60>:  repz  retq
   0x0000000000400f5e <+62>:  xchg   %ax,%ax
   0x0000000000400f60 <+64>:  add    %eax,%eax
   0x0000000000400f62 <+66>:  jmp    0x400f53 <compute+51>
   0x0000000000400f64 <+68>:  nopl  0x0(%rax)
   0x0000000000400f68 <+72>:  sub    $0x1,%eax
   0x0000000000400f6b <+75>:  jmp    0x400f53 <compute+51>
   0x0000000000400f6d <+77>:  nopl  (%rax)
   0x0000000000400f70 <+80>:  mov    $0x494290,%edi
   0x0000000000400f75 <+85>:  jmpq   0x4027d0 <puts>
End of assembler dump.
```