

Bits, Bytes, and Integers (2-2)

15-213/18-243: Introduction to Computer Systems

3rd Lecture, 24 May 2011

Instructors:

Gregory Kesden

Last Time: Bits and Bytes

- Bits, Bytes, Words
- Decimal, binary, hexadecimal representation
- Virtual memory space, addressing, byte ordering
- Boolean algebra
- Bit versus logical operations in C

Today: Integers

■ Integers

- Representation: unsigned and signed
- Conversion, casting
- Expanding, truncating
- Addition, negation, multiplication, shifting

■ Summary

Encoding Integers

Unsigned

$$B2U(X) = \sum_{i=0}^{w-1} x_i \cdot 2^i$$

Two's Complement

$$B2T(X) = -x_{w-1} \cdot 2^{w-1} + \sum_{i=0}^{w-2} x_i \cdot 2^i$$

```
short int x = 15213;
short int y = -15213;
```

Sign
Bit



■ C short 2 bytes long

	Decimal	Hex	Binary
x	15213	3B 6D	00111011 01101101
y	-15213	C4 93	11000100 10010011

■ Sign Bit

- For 2's complement, most significant bit indicates sign
 - 0 for nonnegative
 - 1 for negative

Encoding Example (Cont.)

$x =$ 15213: 00111011 01101101
 $y =$ -15213: 11000100 10010011

Weight	15213		-15213	
1	1	1	1	1
2	0	0	1	2
4	1	4	0	0
8	1	8	0	0
16	0	0	1	16
32	1	32	0	0
64	1	64	0	0
128	0	0	1	128
256	1	256	0	0
512	1	512	0	0
1024	0	0	1	1024
2048	1	2048	0	0
4096	1	4096	0	0
8192	1	8192	0	0
16384	0	0	1	16384
-32768	0	0	1	-32768
Sum	15213		-15213	

Numeric Ranges

■ Unsigned Values

- $UMin = 0$
000...0
- $UMax = 2^w - 1$
111...1

■ Two's Complement Values

- $TMin = -2^{w-1}$
100...0
- $TMax = 2^{w-1} - 1$
011...1

■ Other Values

- Minus 1
111...1

Values for $W = 16$

	Decimal	Hex	Binary
UMax	65535	FF FF	11111111 11111111
TMax	32767	7F FF	01111111 11111111
TMin	-32768	80 00	10000000 00000000
-1	-1	FF FF	11111111 11111111
0	0	00 00	00000000 00000000

Values for Different Word Sizes

	W			
	8	16	32	64
UMax	255	65,535	4,294,967,295	18,446,744,073,709,551,615
TMax	127	32,767	2,147,483,647	9,223,372,036,854,775,807
TMin	-128	-32,768	-2,147,483,648	-9,223,372,036,854,775,808

■ Observations

- $|TMin| = TMax + 1$
 - Asymmetric range
- $UMax = 2 * TMax + 1$

■ C Programming

- `#include <limits.h>`
- Declares constants, e.g.,
 - `ULONG_MAX`
 - `LONG_MAX`
 - `LONG_MIN`
- Values platform specific

Unsigned & Signed Numeric Values

X	$B2U(X)$	$B2T(X)$
0000	0	0
0001	1	1
0010	2	2
0011	3	3
0100	4	4
0101	5	5
0110	6	6
0111	7	7
1000	8	-8
1001	9	-7
1010	10	-6
1011	11	-5
1100	12	-4
1101	13	-3
1110	14	-2
1111	15	-1

■ Equivalence

- Same encodings for nonnegative values

■ Uniqueness

- Every bit pattern represents unique integer value
- Each representable integer has unique bit encoding

■ \Rightarrow Can Invert Mappings

- $U2B(x) = B2U^{-1}(x)$
 - Bit pattern for unsigned integer
- $T2B(x) = B2T^{-1}(x)$
 - Bit pattern for two's comp integer

Today: Bits, Bytes, and Integers

■ Integers

- Representation: unsigned and signed
- **Conversion, casting**
- Expanding, truncating
- Addition, negation, multiplication, shifting

■ Summary

Mapping Between Signed & Unsigned

Two's Complement

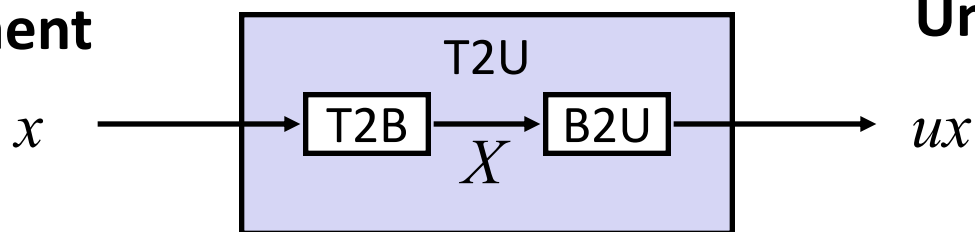

Unsigned

Maintain Same Bit Pattern

Unsigned

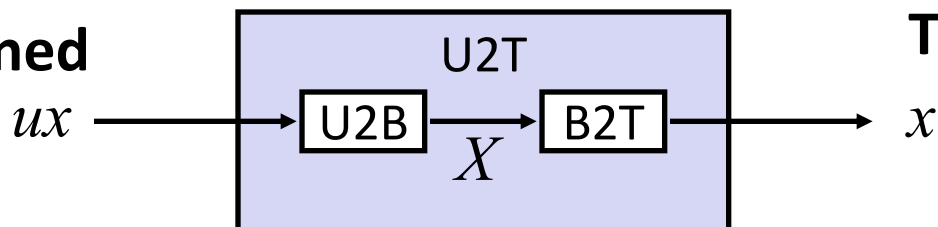

Two's Complement

Maintain Same Bit Pattern

- Mappings between unsigned and two's complement numbers:
keep bit representations and reinterpret

Mapping Signed \leftrightarrow Unsigned

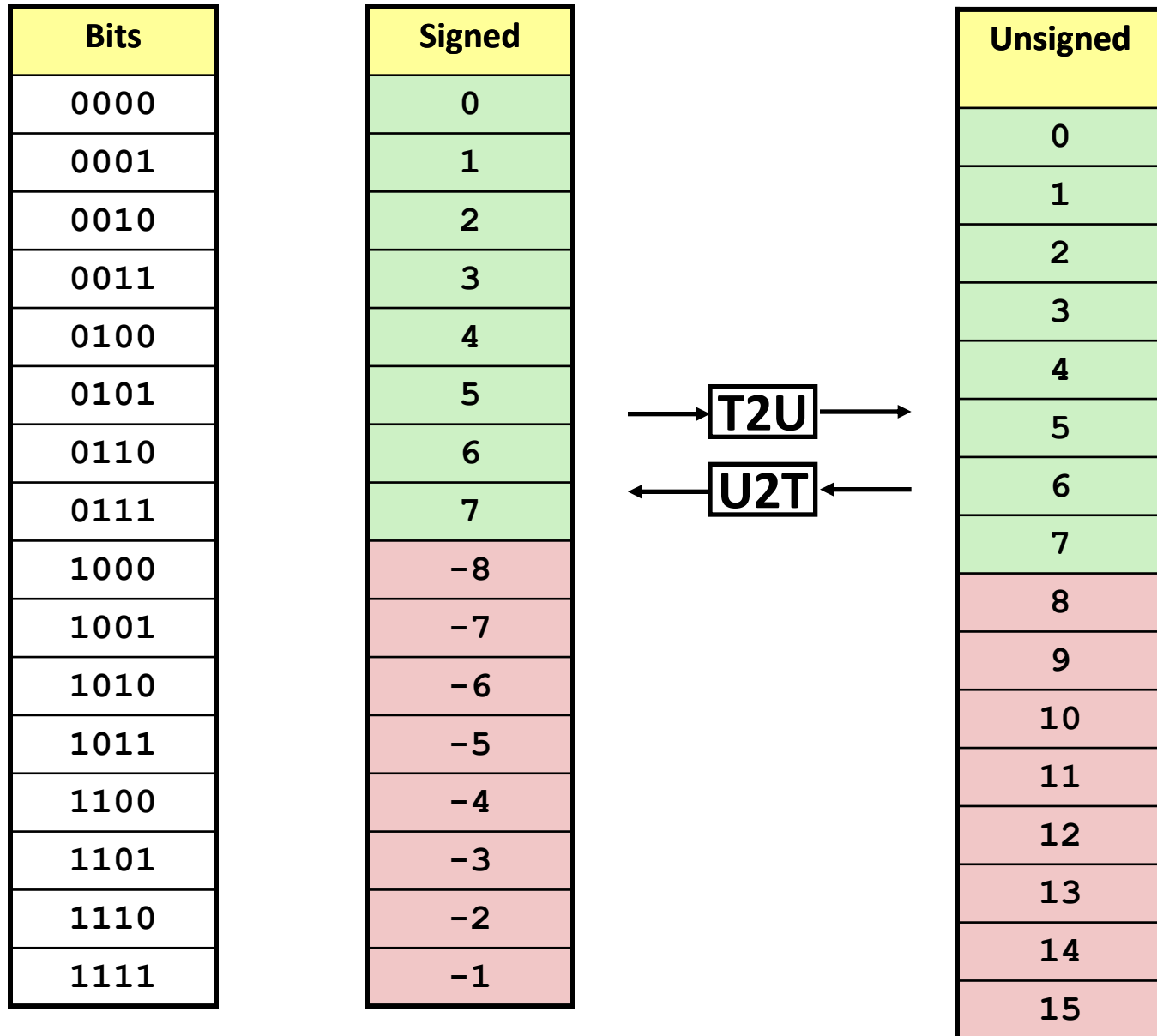

Mapping Signed \leftrightarrow Unsigned

Bits	Signed	Unsigned
0000	0	0
0001	1	1
0010	2	2
0011	3	3
0100	4	4
0101	5	5
0110	6	6
0111	7	7
1000	-8	8
1001	-7	9
1010	-6	10
1011	-5	11
1100	-4	12
1101	-3	13
1110	-2	14
1111	-1	15

=

+/- 16

Relation between Signed & Unsigned

Two's Complement

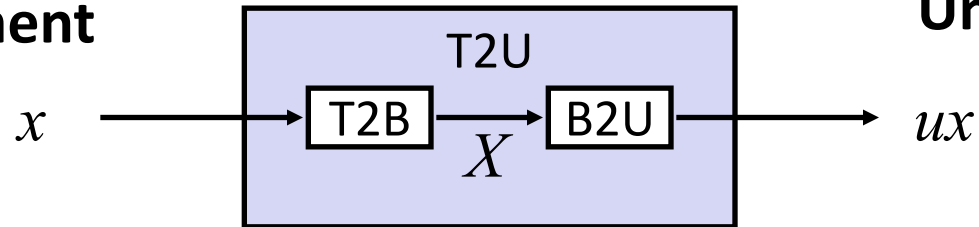

Unsigned

Maintain Same Bit Pattern

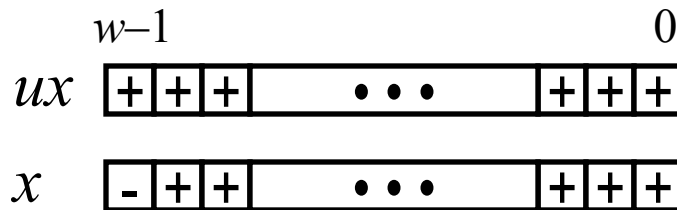

Large negative weight
becomes
Large positive weight

$$ux = \begin{cases} x & x \geq 0 \\ x + 2^w & x < 0 \end{cases}$$

Conversion Visualized

■ 2's Comp. → Unsigned

- Ordering Inversion
- Negative → Big Positive

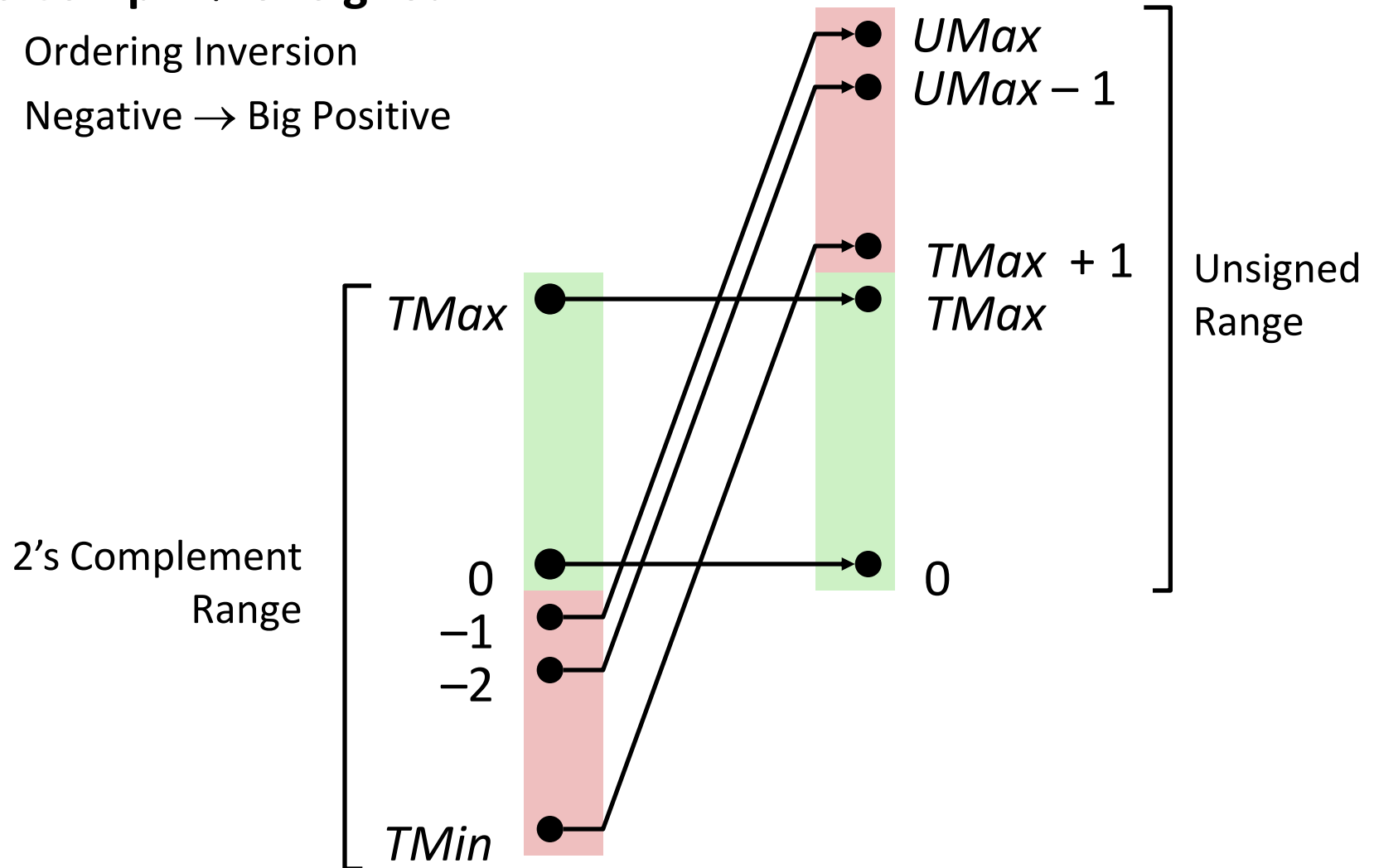

Signed vs. Unsigned in C

■ Constants

- By default are considered to be signed integers
- Unsigned if have “U” as suffix

`0U, 4294967259U`

■ Casting

- Explicit casting between signed & unsigned same as U2T and T2U

```
int tx, ty;
unsigned ux, uy;
tx = (int) ux;
uy = (unsigned) ty;
```

- Implicit casting also occurs via assignments and procedure calls

```
tx = ux;
uy = ty;
```

Casting Surprises

■ Expression Evaluation

- If there is a mix of unsigned and signed in single expression, ***signed values implicitly cast to unsigned***
- Including comparison operations $<$, $>$, $==$, $<=$, $>=$
- Examples for $W = 32$: **$TMIN = -2,147,483,648$** , **$TMAX = 2,147,483,647$**

■ Constant ₁	Constant ₂	Relation	Evaluation
0	0U	==	unsigned
-1	0	<	signed
-1	0U	>	unsigned
2147483647	-2147483647-1	>	signed
2147483647U	-2147483647-1	<	unsigned
-1	-2	>	signed
(unsigned)-1	-2	>	unsigned
2147483647	2147483648U	<	unsigned
2147483647	(int) 2147483648U	>	signed

Code Security Example

```
/* Kernel memory region holding user-accessible data */
#define KSIZE 1024
char kbuf[KSIZE];

/* Copy at most maxlen bytes from kernel region to user buffer */
int copy_from_kernel(void *user_dest, int maxlen) {
    /* Byte count len is minimum of buffer size and maxlen */
    int len = KSIZE < maxlen ? KSIZE : maxlen;
    memcpy(user_dest, kbuf, len);
    return len;
}
```

- Similar to code found in FreeBSD's implementation of `getpeername`
- There are legions of smart people trying to find vulnerabilities in programs

Typical Usage

```
/* Kernel memory region holding user-accessible data */
#define KSIZE 1024
char kbuf[KSIZE];

/* Copy at most maxlen bytes from kernel region to user buffer */
int copy_from_kernel(void *user_dest, int maxlen) {
    /* Byte count len is minimum of buffer size and maxlen */
    int len = KSIZE < maxlen ? KSIZE : maxlen;
    memcpy(user_dest, kbuf, len);
    return len;
}
```

```
#define MSIZE 528

void getstuff() {
    char mybuf[MSIZE];
    copy_from_kernel(mybuf, MSIZE);
    printf("%s\n", mybuf);
}
```

Malicious Usage

```
/* Declaration of library function memcpy */  
void *memcpy(void *dest, void *src, size_t n);
```

```
/* Kernel memory region holding user-accessible data */  
#define KSIZE 1024  
char kbuf[KSIZE];  
  
/* Copy at most maxlen bytes from kernel region to user buffer */  
int copy_from_kernel(void *user_dest, int maxlen) {  
    /* Byte count len is minimum of buffer size and maxlen */  
    int len = KSIZE < maxlen ? KSIZE : maxlen;  
    memcpy(user_dest, kbuf, len);  
    return len;  
}
```

```
#define MSIZE 528  
  
void getstuff() {  
    char mybuf[MSIZE];  
    copy_from_kernel(mybuf, -MSIZE);  
    . . .  
}
```

Summary

Casting Signed \leftrightarrow Unsigned: Basic Rules

- Bit pattern is maintained
- But reinterpreted
- Can have unexpected effects: adding or subtracting 2^w

- Expression containing signed and unsigned int
 - `int` is cast to `unsigned`!!

Today: Bits, Bytes, and Integers

■ Integers

- Representation: unsigned and signed
- Conversion, casting
- **Expanding, truncating**
- Addition, negation, multiplication, shifting

■ Summary

Sign Extension

■ Task:

- Given w -bit signed integer x
- Convert it to $w+k$ -bit integer with same value

■ Rule:

- Make k copies of sign bit:
- $X' = \underbrace{x_{w-1}, \dots, x_{w-1}}_{k \text{ copies of MSB}}, x_{w-1}, x_{w-2}, \dots, x_0$

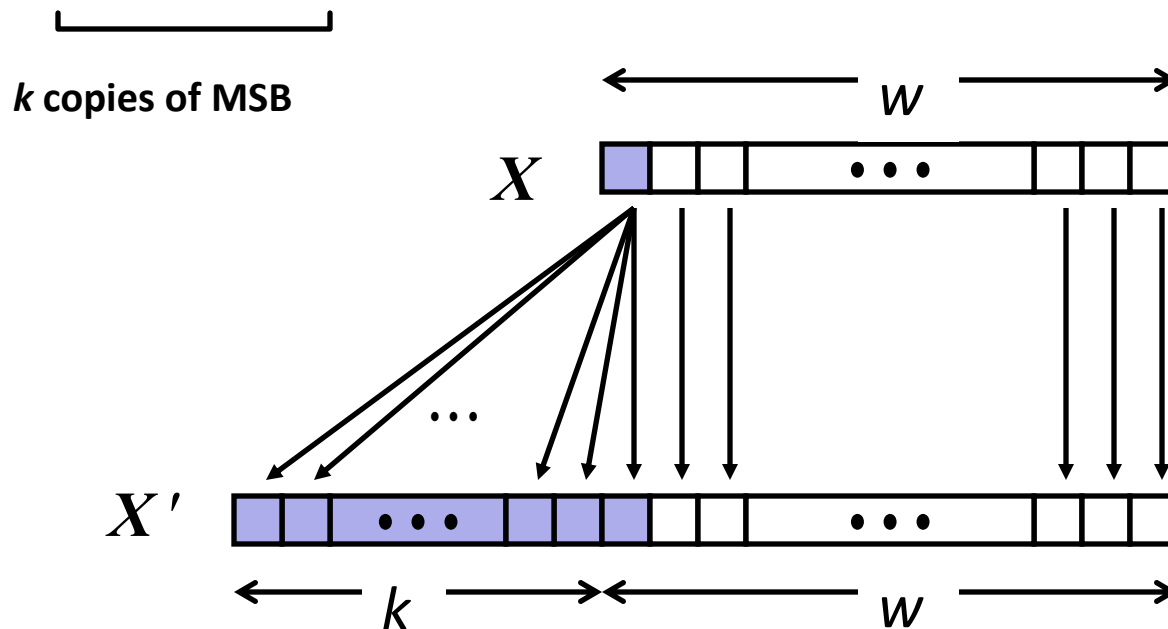

Sign Extension Example

```
short int x = 15213;
int      ix = (int) x;
short int y = -15213;
int      iy = (int) y;
```

	Decimal	Hex	Binary
x	15213	3B 6D	00111011 01101101
ix	15213	00 00 3B 6D	00000000 00000000 00111011 01101101
y	-15213	C4 93	11000100 10010011
iy	-15213	FF FF C4 93	11111111 11111111 11000100 10010011

- Converting from smaller to larger integer data type
- C automatically performs sign extension

Summary:

Expanding, Truncating: Basic Rules

- **Expanding (e.g., short int to int)**
 - Unsigned: zeros added
 - Signed: sign extension
 - Both yield expected result

- **Truncating (e.g., unsigned to unsigned short)**
 - Unsigned/signed: bits are truncated
 - Result reinterpreted
 - Unsigned: mod operation
 - Signed: similar to mod
 - For small numbers yields expected behavior

Today: Bits, Bytes, and Integers

■ Integers

- Representation: unsigned and signed
- Conversion, casting
- Expanding, truncating
- **Addition, negation, multiplication, shifting**

■ Summary

Negation: Complement & Increment

- Claim: Following Holds for 2's Complement

$$\sim x + 1 == -x$$

- Complement

- Observation: $\sim x + x == 1111\dots111 == -1$

$$\begin{array}{r}
 x \quad 10011101 \\
 + \quad \sim x \quad 01100010 \\
 \hline
 -1 \quad 11111111
 \end{array}$$

Complement & Increment Examples

x = 15213

	Decimal	Hex	Binary
x	15213	3B 6D	00111011 01101101
~x	-15214	C4 92	11000100 10010010
~x+1	-15213	C4 93	11000100 10010011
y	-15213	C4 93	11000100 10010011

x = 0

	Decimal	Hex	Binary
0	0	00 00	00000000 00000000
~0	-1	FF FF	11111111 11111111
~0+1	0	00 00	00000000 00000000

Unsigned Addition

Operands: w bits



True Sum: $w+1$ bits

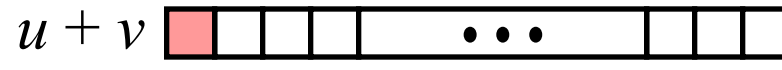

Discard Carry: w bits



■ Standard Addition Function

- Ignores carry output

■ Implements Modular Arithmetic

$$s = UAdd_w(u, v) = u + v \bmod 2^w$$

$$UAdd_w(u, v) = \begin{cases} u + v & u + v < 2^w \\ u + v - 2^w & u + v \geq 2^w \end{cases}$$

Visualizing (Mathematical) Integer Addition

■ Integer Addition

- 4-bit integers u, v
- Compute true sum $\text{Add}_4(u, v)$
- Values increase linearly with u and v
- Forms planar surface

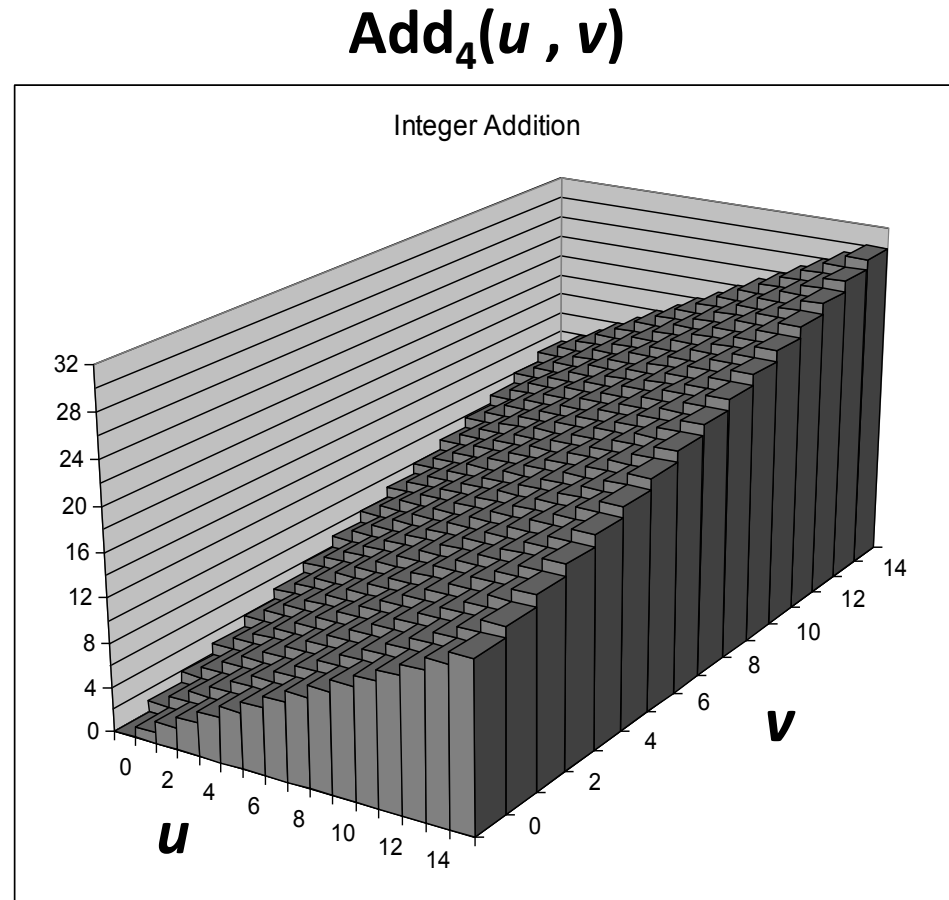

Visualizing Unsigned Addition

■ Wraps Around

- If true sum $\geq 2^w$
- At most once

True Sum

2^{w+1}
 2^w
0

Overflow

Modular Sum

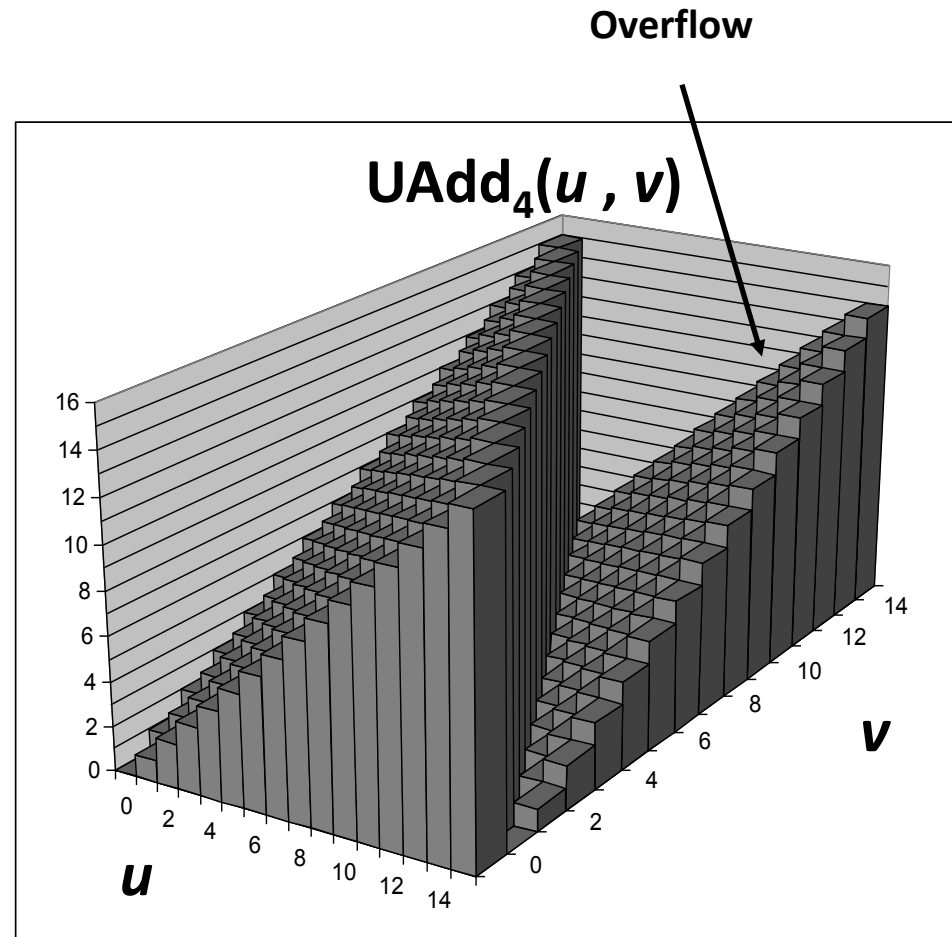

Mathematical Properties

■ Modular Addition Forms an *Abelian Group*

- **Closed** under addition

$$0 \leq \text{UAdd}_w(u, v) \leq 2^w - 1$$

- **Commutative**

$$\text{UAdd}_w(u, v) = \text{UAdd}_w(v, u)$$

- **Associative**

$$\text{UAdd}_w(t, \text{UAdd}_w(u, v)) = \text{UAdd}_w(\text{UAdd}_w(t, u), v)$$

- **0** is additive identity

$$\text{UAdd}_w(u, 0) = u$$

- Every element has additive **inverse**

- Let $\text{UComp}_w(u) = 2^w - u$

$$\text{UAdd}_w(u, \text{UComp}_w(u)) = 0$$

Two's Complement Addition

Operands: w bits



True Sum: $w+1$ bits

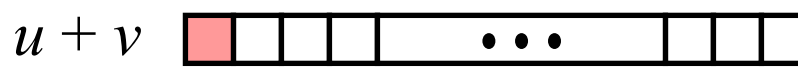

Discard Carry: w bits



■ TAdd and UAdd have Identical Bit-Level Behavior

- Signed vs. unsigned addition in C:

```
int s, t, u, v;
```

```
s = (int) ((unsigned) u + (unsigned) v);
```

```
t = u + v
```

- Will give `s == t`

TAdd Overflow

■ Functionality

- True sum requires $w+1$ bits
- Drop off MSB
- Treat remaining bits as 2's comp. integer

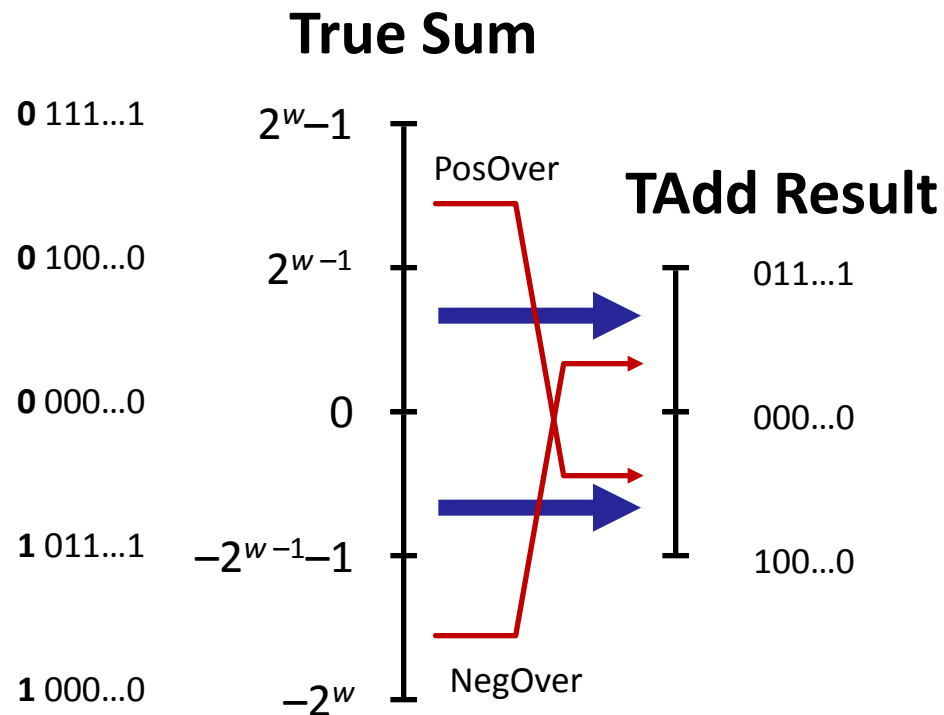

Visualizing 2's Complement Addition

■ Values

- 4-bit two's comp.
- Range from -8 to +7

■ Wraps Around

- If $\text{sum} \geq 2^{w-1}$
 - Becomes negative
 - At most once
- If $\text{sum} < -2^{w-1}$
 - Becomes positive
 - At most once

NegOver

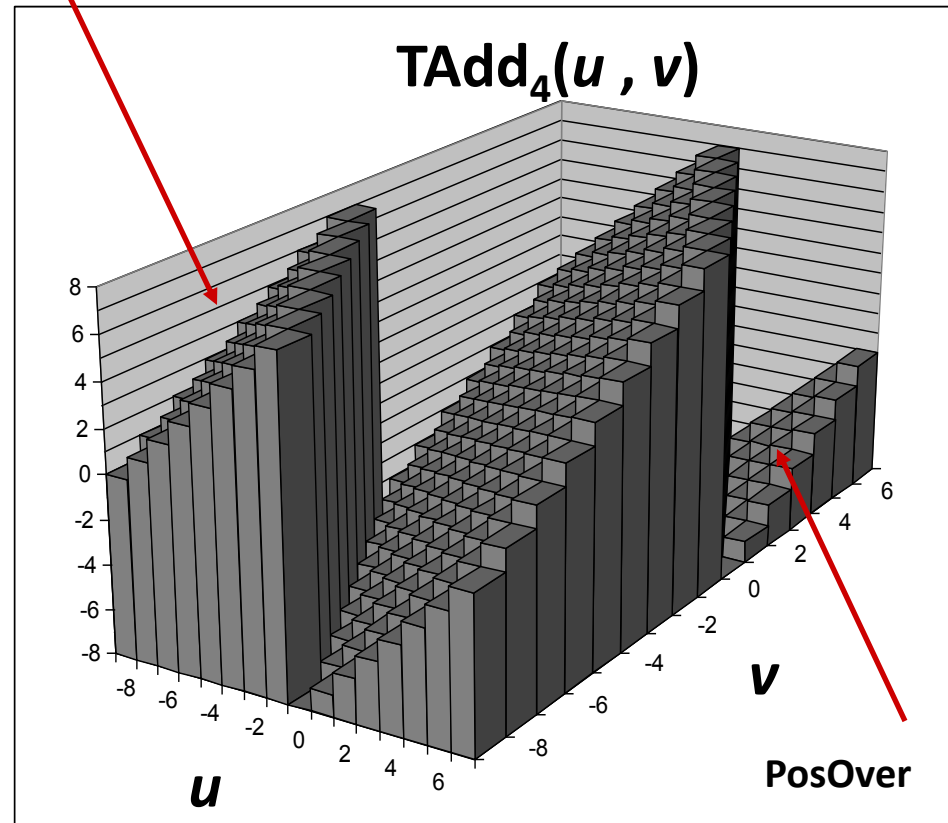

Characterizing TAdd

■ Functionality

- True sum requires $w+1$ bits
- Drop off MSB
- Treat remaining bits as 2's comp. integer

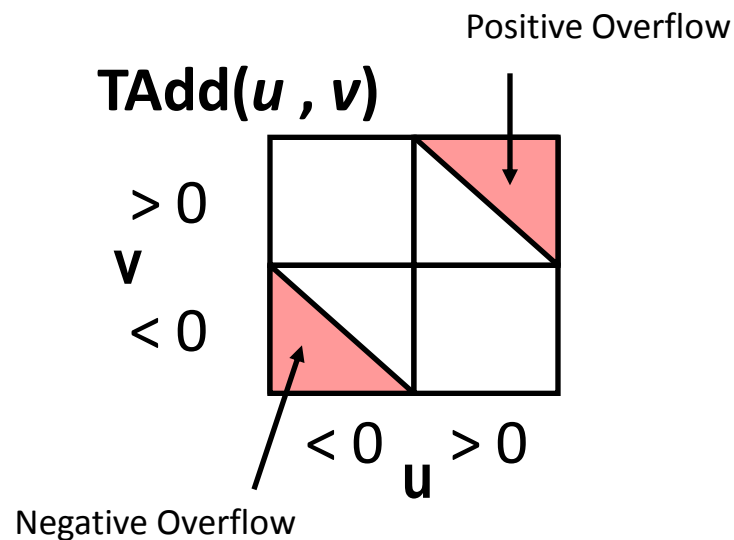

$$TAdd_w(u, v) = \begin{cases} u + v + 2^w & u + v < TMin_w \text{ (NegOver)} \\ u + v & TMin_w \leq u + v \leq TMax_w \\ u + v - 2^w & TMax_w < u + v \text{ (PosOver)} \end{cases}$$

Mathematical Properties of TAdd

■ Isomorphic Group to unsigneds with UAdd

- $TAdd_w(u, v) = U2T(UAdd_w(T2U(u), T2U(v)))$
 - Since both have identical bit patterns

■ Two's Complement Under TAdd Forms a Group

- Closed, Commutative, Associative, 0 is additive identity
- Every element has additive inverse

$$TComp_w(u) = \begin{cases} -u & u \neq TMin_w \\ TMin_w & u = TMin_w \end{cases}$$

Multiplication

■ Computing Exact Product of w -bit numbers x, y

- Either signed or unsigned

■ Ranges

- Unsigned: $0 \leq x * y \leq (2^w - 1)^2 = 2^{2w} - 2^{w+1} + 1$
 - Up to $2w$ bits
- Two's complement min: $x * y \geq (-2^{w-1}) * (2^{w-1} - 1) = -2^{2w-2} + 2^{w-1}$
 - Up to $2w-1$ bits
- Two's complement max: $x * y \leq (-2^{w-1})^2 = 2^{2w-2}$
 - Up to $2w$ bits, but only for $(TMin_w)^2$

■ Maintaining Exact Results

- Would need to keep expanding word size with each product computed
- Done in software by “arbitrary precision” arithmetic packages

Unsigned Multiplication in C

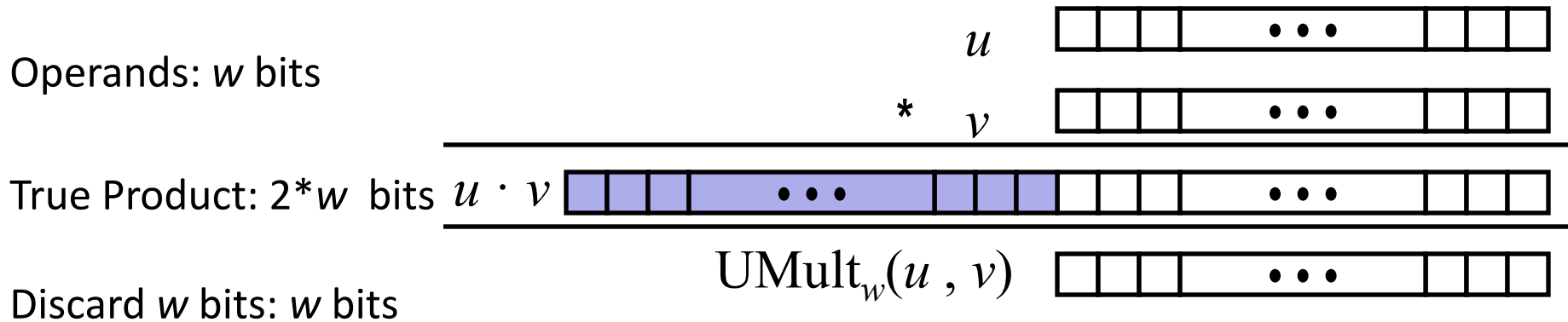

■ Standard Multiplication Function

- Ignores high order w bits

■ Implements Modular Arithmetic

$$\text{UMult}_w(u, v) = u \cdot v \bmod 2^w$$

Code Security Example #2

■ SUN XDR library

- Widely used library for transferring data between machines

```
void* copy_elements(void *ele_src[], int ele_cnt, size_t ele_size);
```

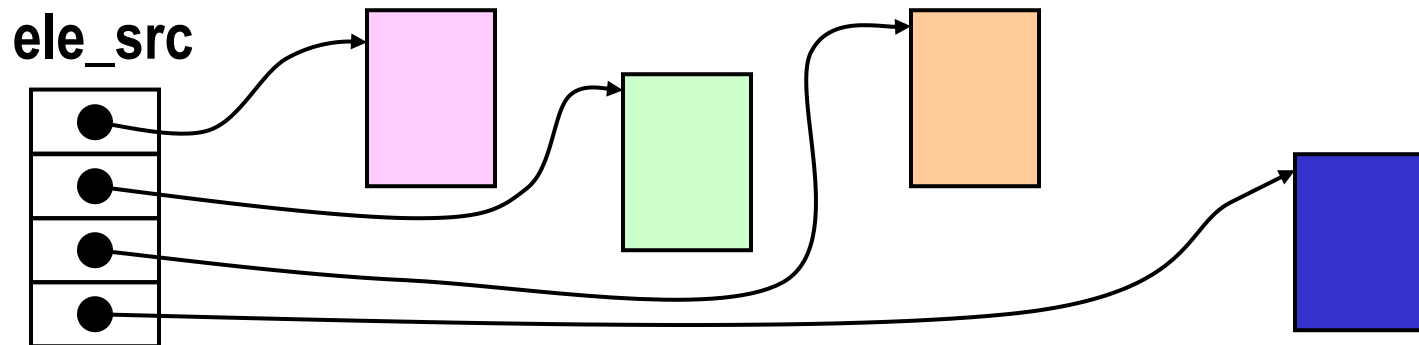

`malloc(ele_cnt * ele_size)`

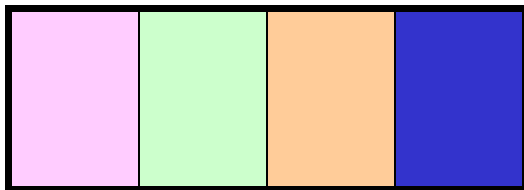

XDR Code

```
void* copy_elements(void *ele_src[], int ele_cnt, size_t ele_size) {
    /*
     * Allocate buffer for ele_cnt objects, each of ele_size bytes
     * and copy from locations designated by ele_src
     */
    void *result = malloc(ele_cnt * ele_size);
    if (result == NULL)
        /* malloc failed */
        return NULL;
    void *next = result;
    int i;
    for (i = 0; i < ele_cnt; i++) {
        /* Copy object i to destination */
        memcpy(next, ele_src[i], ele_size);
        /* Move pointer to next memory region */
        next += ele_size;
    }
    return result;
}
```

XDR Vulnerability

`malloc(ele_cnt * ele_size)`

■ What if:

- `ele_cnt` = $2^{20} + 1$
- `ele_size` = 4096 = 2^{12}
- Allocation = ??

■ How can I make this function secure?

Signed Multiplication in C

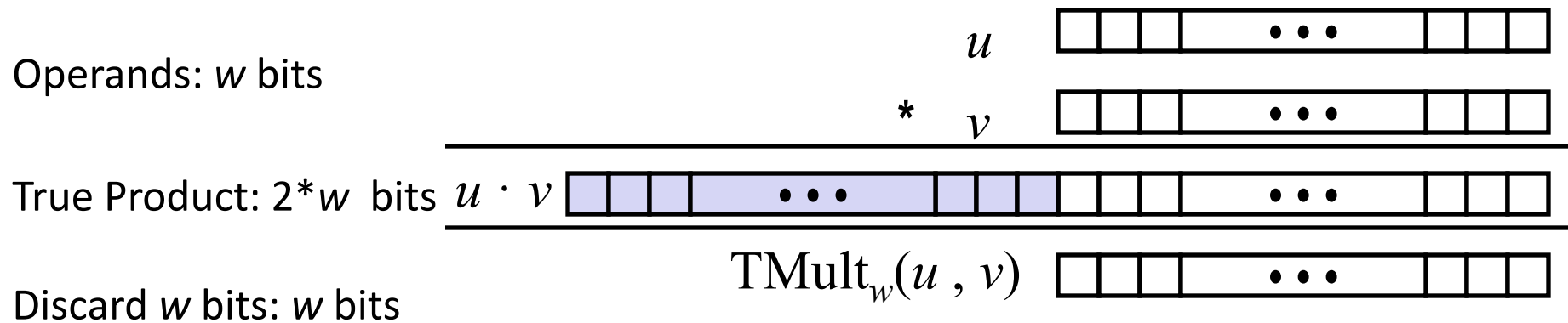

■ Standard Multiplication Function

- Ignores high order w bits
- Some of which are different for signed vs. unsigned multiplication
- Lower bits are the same

Power-of-2 Multiply with Shift

■ Operation

- $u \ll k$ gives $u * 2^k$
- Both signed and unsigned

Operands: w bits

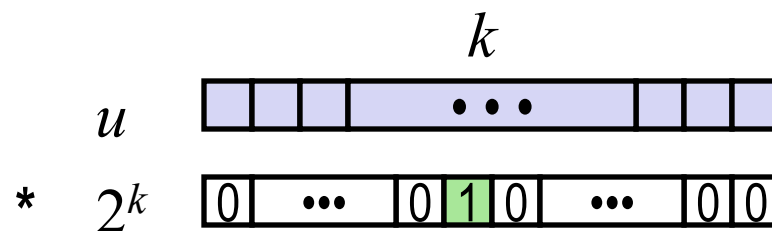

True Product: $w+k$ bits



Discard k bits: w bits

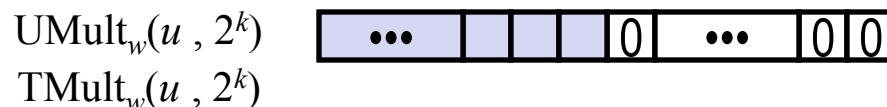

■ Examples

- $u \ll 3 \quad \quad \quad == \quad u * 8$
- $u \ll 5 - u \ll 3 \quad == \quad u * 24$
- Most machines shift and add faster than multiply
 - Compiler generates this code automatically

Compiled Multiplication Code

C Function

```
int mul12(int x)
{
    return x*12;
}
```

Compiled Arithmetic Operations

```
leal (%eax,%eax,2), %eax
sall $2, %eax
```

Explanation

```
t <- x+x*2
return t << 2;
```

- C compiler automatically generates shift/add code when multiplying by constant

Unsigned Power-of-2 Divide with Shift

■ Quotient of Unsigned by Power of 2

- $u \gg k$ gives $\lfloor u / 2^k \rfloor$
- Uses logical shift

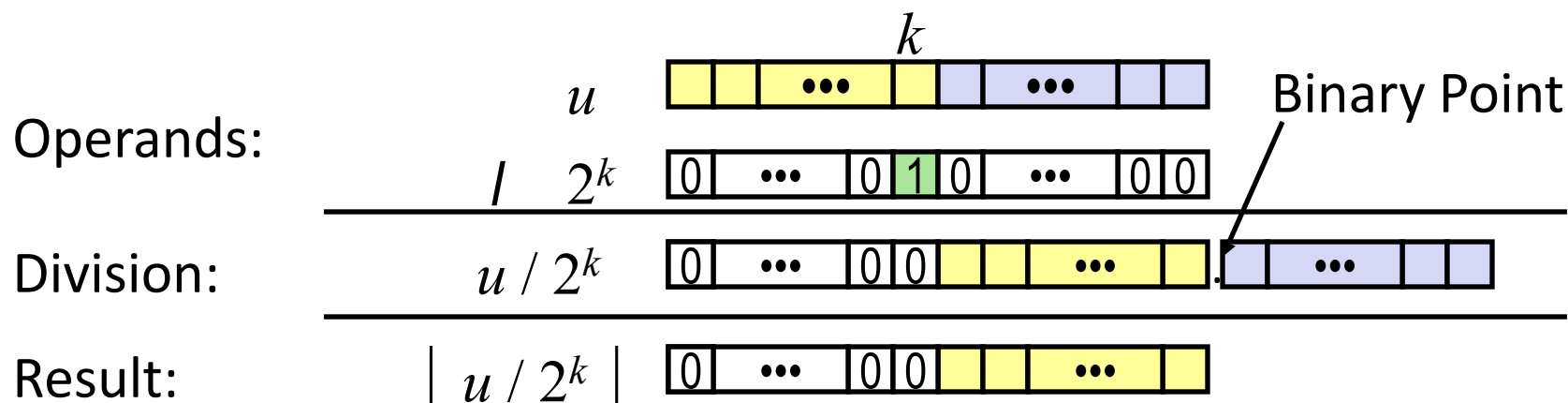

	Division	Computed	Hex	Binary
x	15213	15213	3B 6D	00111011 01101101
x >> 1	7606.5	7606	1D B6	00011101 10110110
x >> 4	950.8125	950	03 B6	00000011 10110110
x >> 8	59.4257813	59	00 3B	00000000 00111011

Compiled Unsigned Division Code

C Function

```
unsigned udiv8(unsigned x)
{
    return x/8;
}
```

Compiled Arithmetic Operations

```
shrl $3, %eax
```

Explanation

```
# Logical shift
return x >> 3;
```

- Uses logical shift for unsigned
- For Java Users
 - Logical shift written as >>>

Signed Power-of-2 Divide with Shift

■ Quotient of Signed by Power of 2

- $x \gg k$ gives $\lfloor x / 2^k \rfloor$
- Uses arithmetic shift
- Rounds wrong direction when $u < 0$

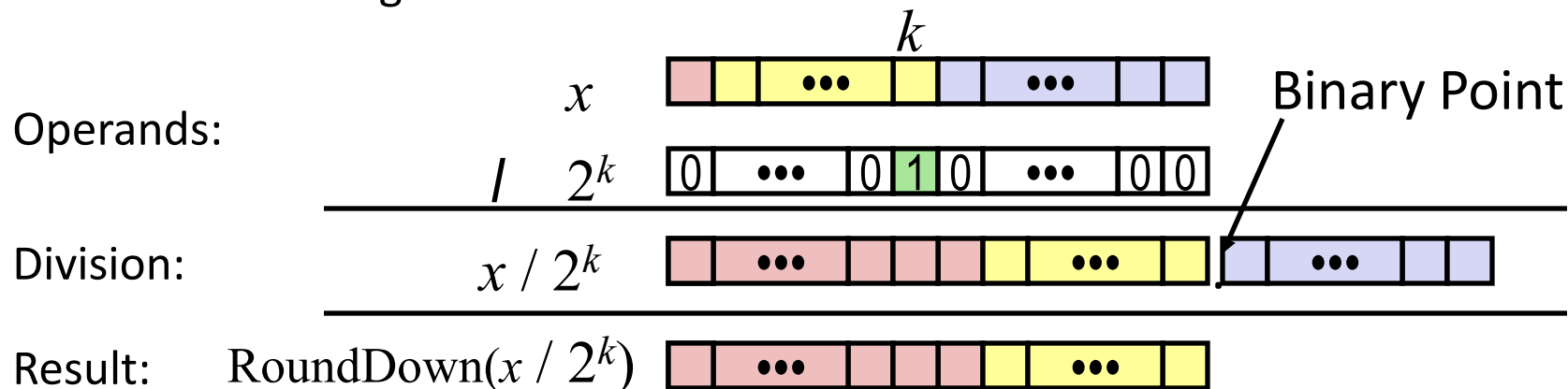

	Division	Computed	Hex	Binary
y	-15213	-15213	C4 93	11000100 10010011
$y \gg 1$	-7606.5	-7607	E2 49	11100010 01001001
$y \gg 4$	-950.8125	-951	FC 49	11111100 01001001
$y \gg 8$	-59.4257813	-60	FF C4	11111111 11000100

Correct Power-of-2 Divide

■ Quotient of Negative Number by Power of 2

- Want $\lceil \mathbf{x} / 2^k \rceil$ (Round Toward 0)
- Compute as $\lfloor (\mathbf{x} + 2^k - 1) / 2^k \rfloor$
 - In C: $(\mathbf{x} + (1 \ll k) - 1) \gg k$
 - Biases dividend toward 0

Case 1: No rounding

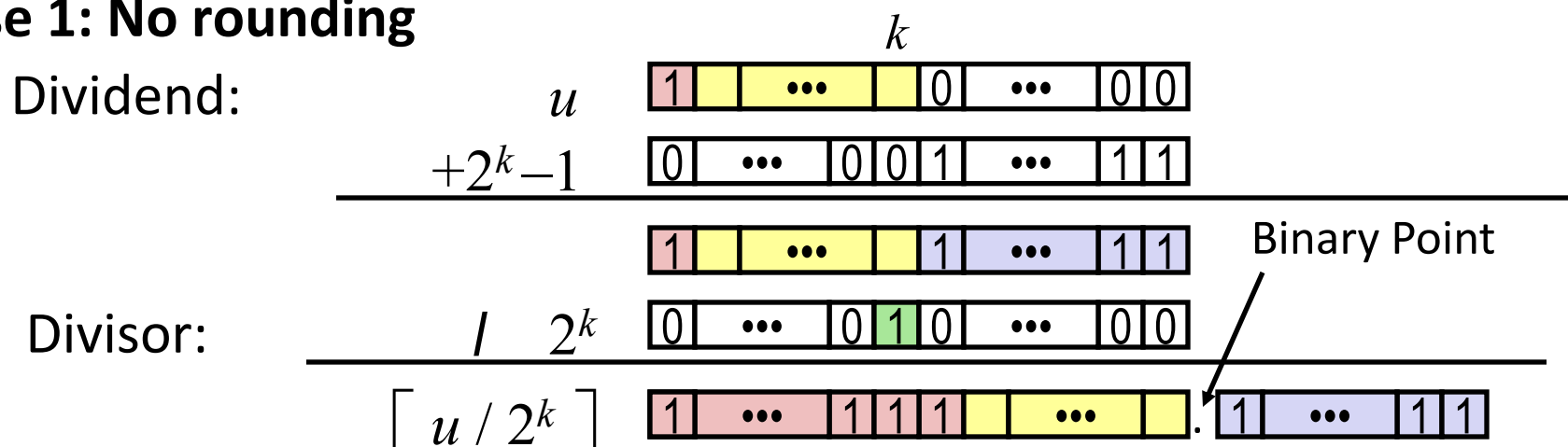

Biassing has no effect

Correct Power-of-2 Divide (Cont.)

Case 2: Rounding

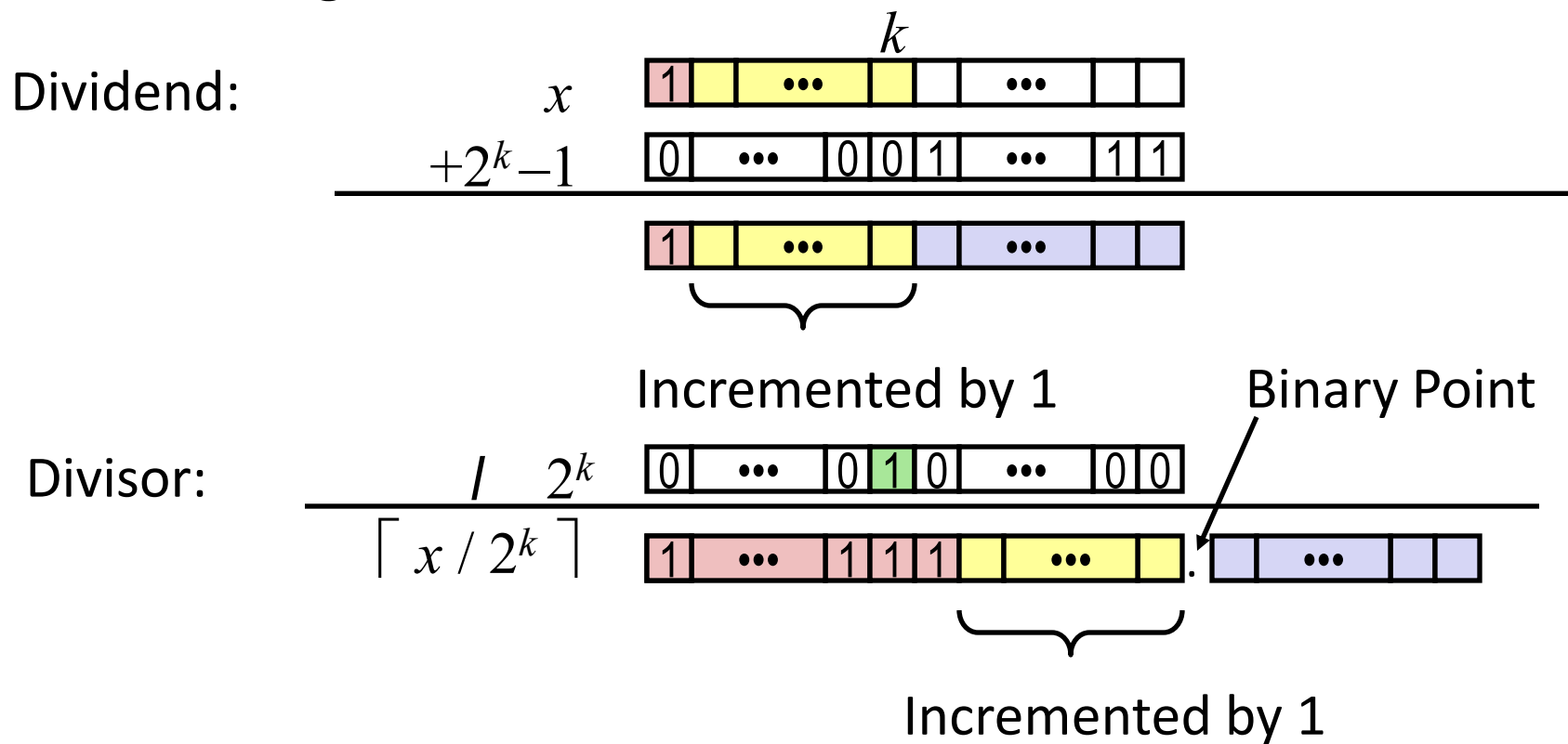

Biasing adds 1 to final result

Compiled Signed Division Code

C Function

```
int idiv8(int x)
{
    return x/8;
}
```

Compiled Arithmetic Operations

```
    testl %eax, %eax
    js    L4
L3:
    sarl $3, %eax
    ret
L4:
    addl $7, %eax
    jmp  L3
```

Explanation

```
    if x < 0
        x += 7;
    # Arithmetic shift
    return x >> 3;
```

- Uses arithmetic shift for int
- For Java Users
 - Arith. shift written as >>

Arithmetic: Basic Rules

■ Addition:

- Unsigned/signed: Normal addition followed by truncate, same operation on bit level
- Unsigned: addition mod 2^w
 - Mathematical addition + possible subtraction of $2w$
- Signed: modified addition mod 2^w (result in proper range)
 - Mathematical addition + possible addition or subtraction of $2w$

■ Multiplication:

- Unsigned/signed: Normal multiplication followed by truncate, same operation on bit level
- Unsigned: multiplication mod 2^w
- Signed: modified multiplication mod 2^w (result in proper range)

Arithmetic: Basic Rules

- **Unsigned ints, 2's complement ints are isomorphic rings: isomorphism = casting**
- **Left shift**
 - Unsigned/signed: multiplication by 2^k
 - Always logical shift
- **Right shift**
 - Unsigned: logical shift, div (division + round to zero) by 2^k
 - Signed: arithmetic shift
 - Positive numbers: div (division + round to zero) by 2^k
 - Negative numbers: div (division + round away from zero) by 2^k
Use biasing to fix

Today: Integers

- Representation: unsigned and signed
- Conversion, casting
- Expanding, truncating
- Addition, negation, multiplication, shifting
- **Summary**

Properties of Unsigned Arithmetic

■ Unsigned Multiplication with Addition Forms Commutative Ring

- Addition is commutative group
- Closed under multiplication
$$0 \leq \text{UMult}_w(u, v) \leq 2^w - 1$$
- Multiplication Commutative
$$\text{UMult}_w(u, v) = \text{UMult}_w(v, u)$$
- Multiplication is Associative
$$\text{UMult}_w(t, \text{UMult}_w(u, v)) = \text{UMult}_w(\text{UMult}_w(t, u), v)$$
- 1 is multiplicative identity
$$\text{UMult}_w(u, 1) = u$$
- Multiplication distributes over addition
$$\text{UMult}_w(t, \text{UAdd}_w(u, v)) = \text{UAdd}_w(\text{UMult}_w(t, u), \text{UMult}_w(t, v))$$

Properties of Two's Comp. Arithmetic

■ Isomorphic Algebras

- Unsigned multiplication and addition
 - Truncating to w bits
- Two's complement multiplication and addition
 - Truncating to w bits

■ Both Form Rings

- Isomorphic to ring of integers mod 2^w

■ Comparison to (Mathematical) Integer Arithmetic

- Both are rings
- Integers obey ordering properties, e.g.,

$$u > 0 \quad \Rightarrow \quad u + v > v$$

$$u > 0, v > 0 \quad \Rightarrow \quad u \cdot v > 0$$

- These properties are not obeyed by two's comp. arithmetic

$$TMax + 1 \quad == \quad TMin$$

$$15213 * 30426 \quad == \quad -10030 \quad (16\text{-bit words})$$

Why Should I Use Unsigned?

■ *Don't Use Just Because Number Nonnegative*

- Easy to make mistakes

```
unsigned i;  
for (i = cnt-2; i >= 0; i--)  
    a[i] += a[i+1];
```

- Can be very subtle

```
#define DELTA sizeof(int)  
int i;  
for (i = CNT; i-DELTA >= 0; i-= DELTA)  
    . . .
```

■ *Do Use When Performing Modular Arithmetic*

- Multiprecision arithmetic

■ *Do Use When Using Bits to Represent Sets*

- Logical right shift, no sign extension

Integer C Puzzles

Argue that it is always true or provide a counter example.

Assume 32-bit architecture

Initialization

```
int x = foo();
int y = bar();
unsigned ux = x;
unsigned uy = y;
```

- $x < 0 \Rightarrow ((x*2) < 0)$
- $ux \geq 0$
- $x \& 7 == 7 \Rightarrow (x \ll 30) < 0$
- $ux > -1$
- $x > y \Rightarrow -x < -y$
- $x * x \geq 0$
- $x > 0 \ \&\& \ y > 0 \Rightarrow x + y > 0$
- $x \geq 0 \Rightarrow -x \leq 0$
- $x \leq 0 \Rightarrow -x \geq 0$
- $(x|-x) \gg 31 == -1$
- $ux \gg 3 == ux/8$
- $x \gg 3 == x/8$
- $x \& (x-1) != 0$