

Concurrent Programming

15-213 / 18-213: Introduction to Computer Systems
23rd Lecture, April 9, 2015

Instructors:

Seth Copen Goldstein, Franz Franchetti, Greg Kesden

Concurrent Programming is Hard!

- **The human mind tends to be sequential**
- **The notion of time is often misleading**
- **Thinking about all possible sequences of events in a computer system is at least error prone and frequently impossible**

Data Race

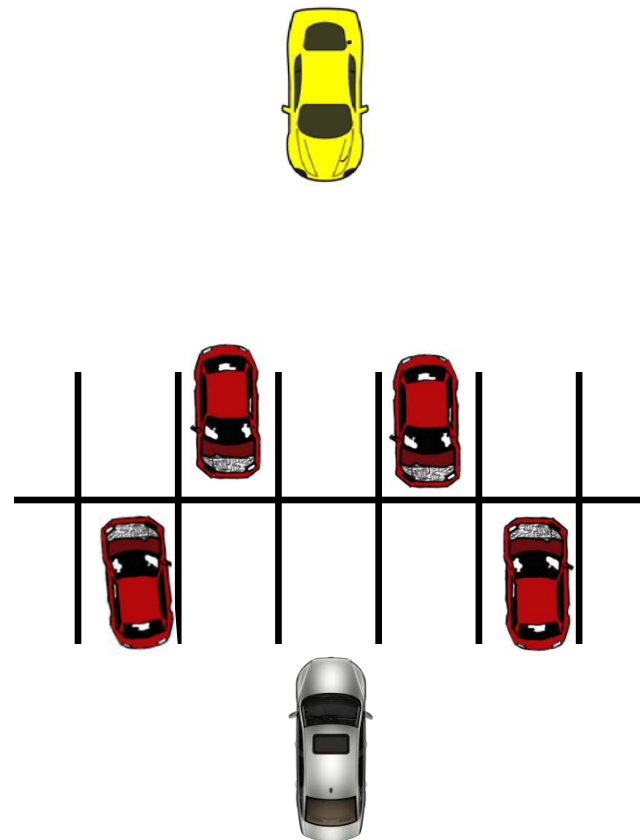

Deadlock

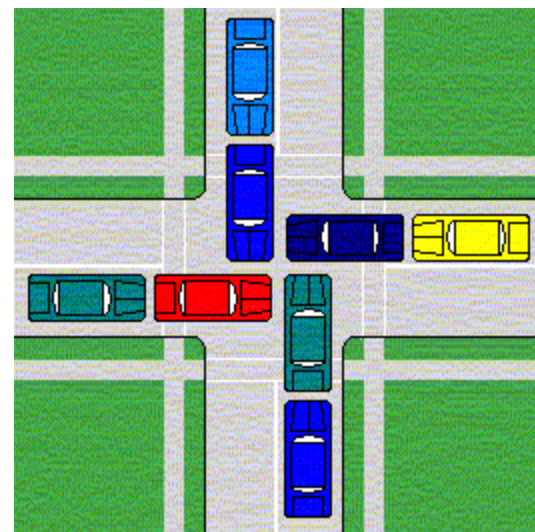

Livelock



Livelock

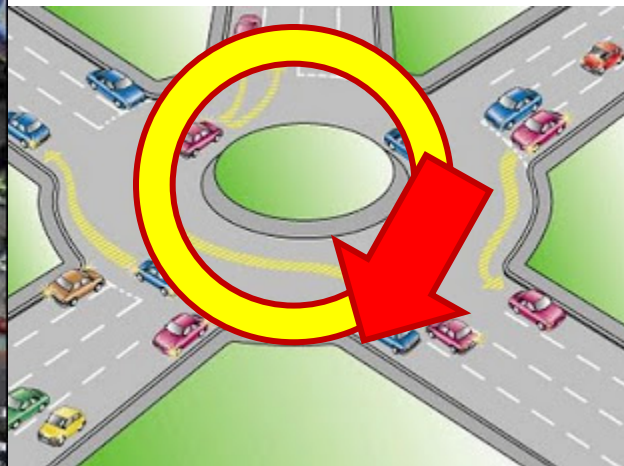

Livelock

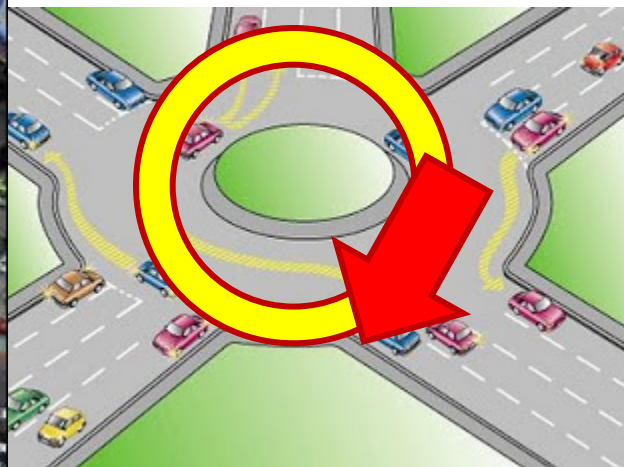

Concurrent Programming is Hard!

- **Classical problem classes of concurrent programs:**
 - **Races:** outcome depends on arbitrary scheduling decisions elsewhere in the system
 - Example: who gets the last seat on the airplane?
 - **Deadlock:** improper resource allocation prevents forward progress
 - Example: traffic gridlock
 - **Livelock / Starvation / Fairness:** external events and/or system scheduling decisions can prevent sub-task progress
 - Example: people always jump in front of you in line
- **Many aspects of concurrent programming are beyond the scope of 15-213**
 - but, not all 😊

Reminder: Iterative Echo Server

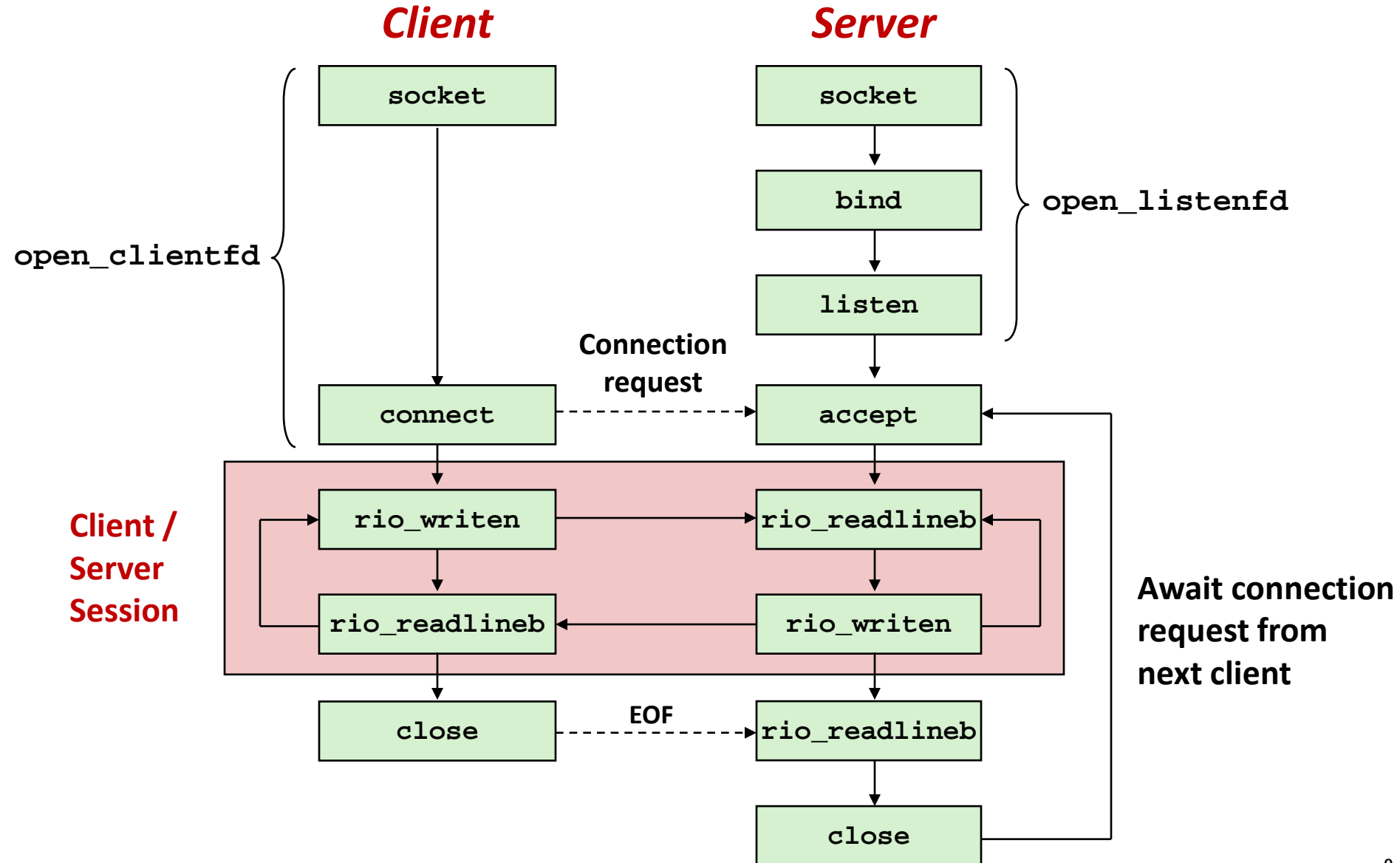

Iterative Servers

- Iterative servers process one request at a time

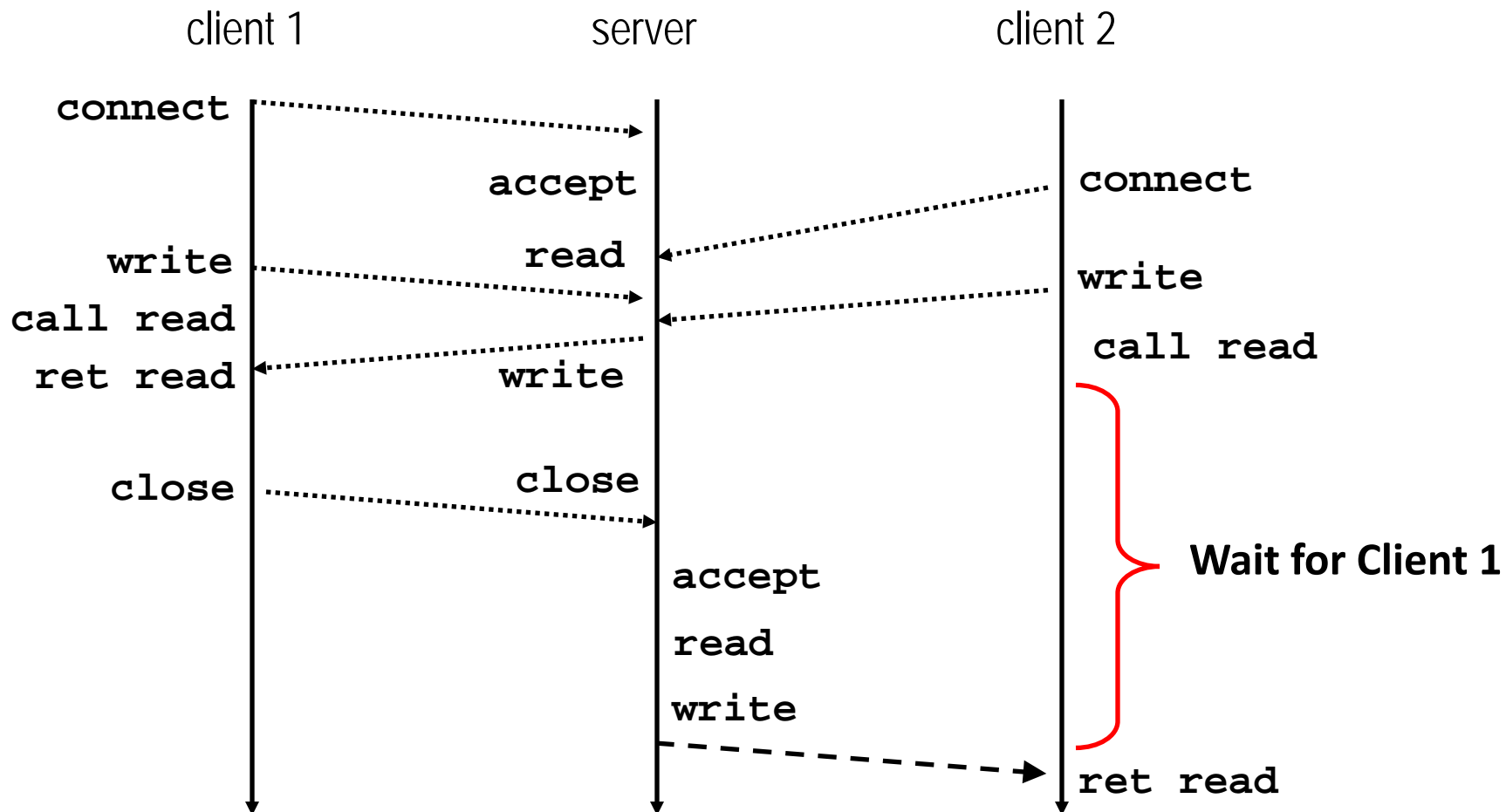

Where Does Second Client Block?

- Second client attempts to connect to iterative server

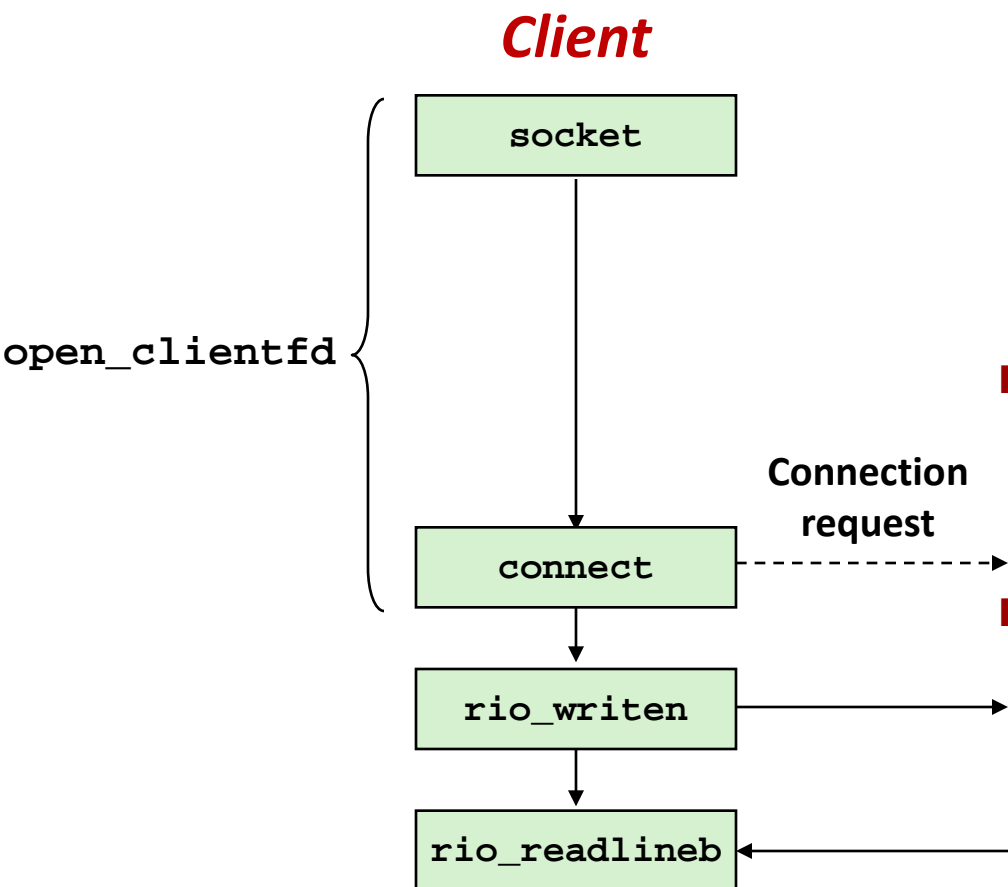

- Call to connect returns

- Even though connection not yet accepted
- Server side TCP manager queues request
- Feature known as “TCP listen backlog”

- Call to rio_writen returns

- Server side TCP manager buffers input data

- Call to rio_readlineb blocks

- Server hasn't written anything for it to read yet.

Fundamental Flaw of Iterative Servers

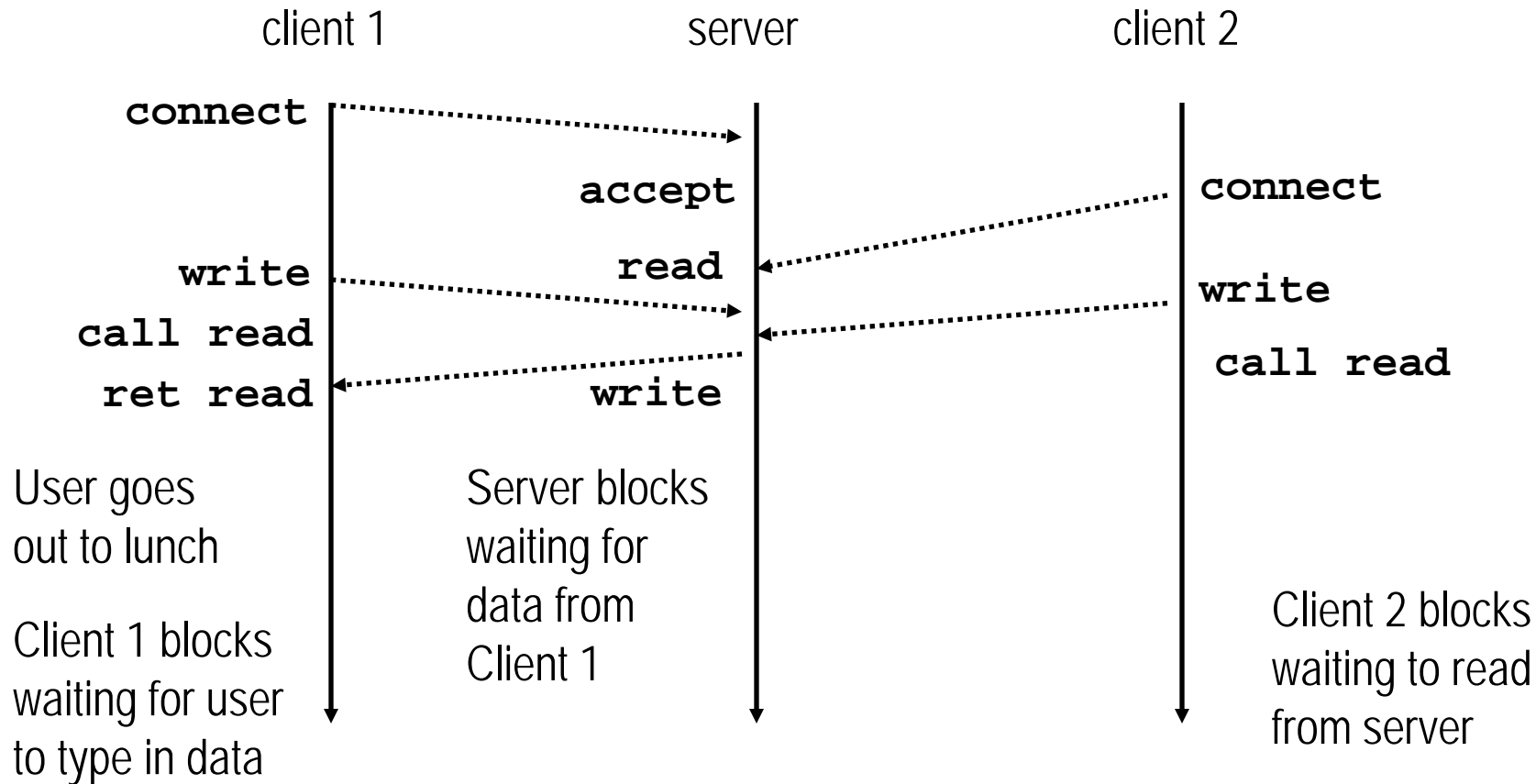

■ Solution: use *concurrent servers* instead

- Concurrent servers use multiple concurrent flows to serve multiple clients at the same time

Server concurrency (3 approaches)

Allow server to handle multiple clients simultaneously

■ 1. Processes

- Kernel automatically interleaves multiple logical flows
- Each flow has its own private address space

■ 2. Threads

- Kernel automatically interleaves multiple logical flows
- Each flow shares the same address space

■ 3. I/O multiplexing with `select ()`

- Programmer manually interleaves multiple logical flows
- All flows share the same address space
- Relies on lower-level system abstractions

Concurrent Servers: Multiple Processes

- Spawn separate process for each client

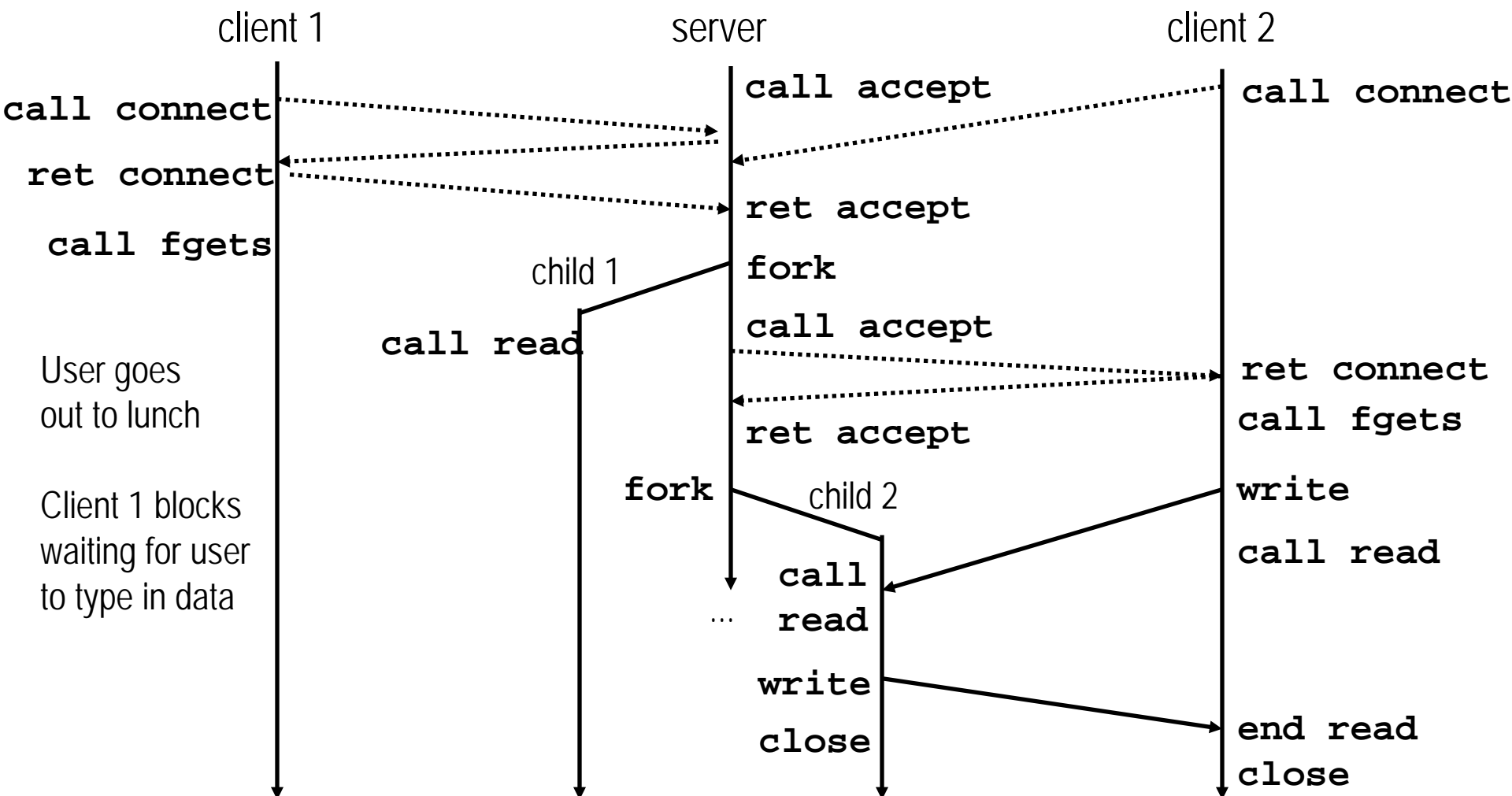

Review: Iterative Echo Server

```
int main(int argc, char **argv)
{
    int listenfd, connfd;
    int port = atoi(argv[1]);
    struct sockaddr_in clientaddr;
    int clientlen = sizeof(clientaddr);

    listenfd = Open_listenfd(port);
    while (1) {
        connfd = Accept(listenfd, (SA *)&clientaddr, &clientlen);
        echo(connfd);
        Close(connfd);
    }
    exit(0);
}
```

- Accept a connection request
- Handle echo requests until client terminates

Making A Concurrent Echo Server

```
int main(int argc, char **argv)
{
    int listenfd, connfd;
    int port = atoi(argv[1]);
    struct sockaddr_in clientaddr;
    int clientlen=sizeof(clientaddr);

    listenfd = Open_listenfd(port);
    while (1) {
        connfd = Accept(listenfd, (SA *) &clientaddr, &clientlen);

        echo(connfd);    /* Child services client */
        Close(connfd);  /* Child closes connection with client */

    }
}
```

Making A Concurrent Echo Server

```
int main(int argc, char **argv)
{
    int listenfd, connfd;
    int port = atoi(argv[1]);
    struct sockaddr_in clientaddr;
    int clientlen=sizeof(clientaddr);

    listenfd = Open_listenfd(port);
    while (1) {
        connfd = Accept(listenfd, (SA *) &clientaddr, &clientlen);
        if (Fork() == 0) {

            echo(connfd);      /* Child services client */
            Close(connfd);    /* Child closes connection with client */
            exit(0);          /* Child exits */
        }
    }
}
```

Making A Concurrent Echo Server

```
int main(int argc, char **argv)
{
    int listenfd, connfd;
    int port = atoi(argv[1]);
    struct sockaddr_in clientaddr;
    int clientlen=sizeof(clientaddr);

    Signal(SIGCHLD, sigchld_handler);
    listenfd = Open_listenfd(port);
    while (1) {
        connfd = Accept(listenfd, (SA *) &clientaddr, &clientlen);
        if (Fork() == 0) {

            echo(connfd);      /* Child services client */
            Close(connfd);    /* Child closes connection with client */
            exit(0);          /* Child exits */
        }
    }
}
```

Making A Concurrent Echo Server

```
int main(int argc, char **argv)
{
    int listenfd, connfd;
    int port = atoi(argv[1]);
    struct sockaddr_in clientaddr;
    int clientlen=sizeof(clientaddr);

    Signal(SIGCHLD, sigchld_handler);
    listenfd = Open_listenfd(port);
    while (1) {
        connfd = Accept(listenfd, (SA *) &clientaddr, &clientlen);
        if (Fork() == 0) {
            Close(listenfd); /* Child closes its listening socket */
            echo(connfd);    /* Child services client */
            Close(connfd);  /* Child closes connection with client */
            exit(0);        /* Child exits */
        }
    }
}
```

Making A Concurrent Echo Server

```
int main(int argc, char **argv)
{
    int listenfd, connfd;
    int port = atoi(argv[1]);
    struct sockaddr_in clientaddr;
    int clientlen=sizeof(clientaddr);

    Signal(SIGCHLD, sigchld_handler);
    listenfd = Open_listenfd(port);
    while (1) {
        connfd = Accept(listenfd, (SA *) &clientaddr, &clientlen);
        if (Fork() == 0) {
            Close(listenfd); /* Child closes its listening socket */
            echo(connfd);    /* Child services client */
            Close(connfd);  /* Child closes connection with client */
            exit(0);        /* Child exits */
        }
        Close(connfd); /* Parent closes connected socket (important!) */
    }
}
```

Process-Based Concurrent Echo Server

```
int main(int argc, char **argv)
{
    int listenfd, connfd;
    int port = atoi(argv[1]);
    struct sockaddr_in clientaddr;
    int clientlen=sizeof(clientaddr);

    Signal(SIGCHLD, sigchld_handler);
    listenfd = Open_listenfd(port);
    while (1) {
        connfd = Accept(listenfd, (SA *) &clientaddr, &clientlen);
        if (Fork() == 0) {
            Close(listenfd); /* Child closes its listening socket */
            echo(connfd);    /* Child services client */
            Close(connfd);  /* Child closes connection with client */
            exit(0);        /* Child exits */
        }
        Close(connfd); /* Parent closes connected socket (important!) */
    }
}
```

Fork separate process for
each client
Does not allow any
communication between
different client handlers

Process-Based Concurrent Echo Server (cont)

```
void sigchld_handler(int sig)
{
    while (waitpid(-1, 0, WNOHANG) > 0)
        ;
    return;
}
```

- Reap all zombie children

Process Execution Model

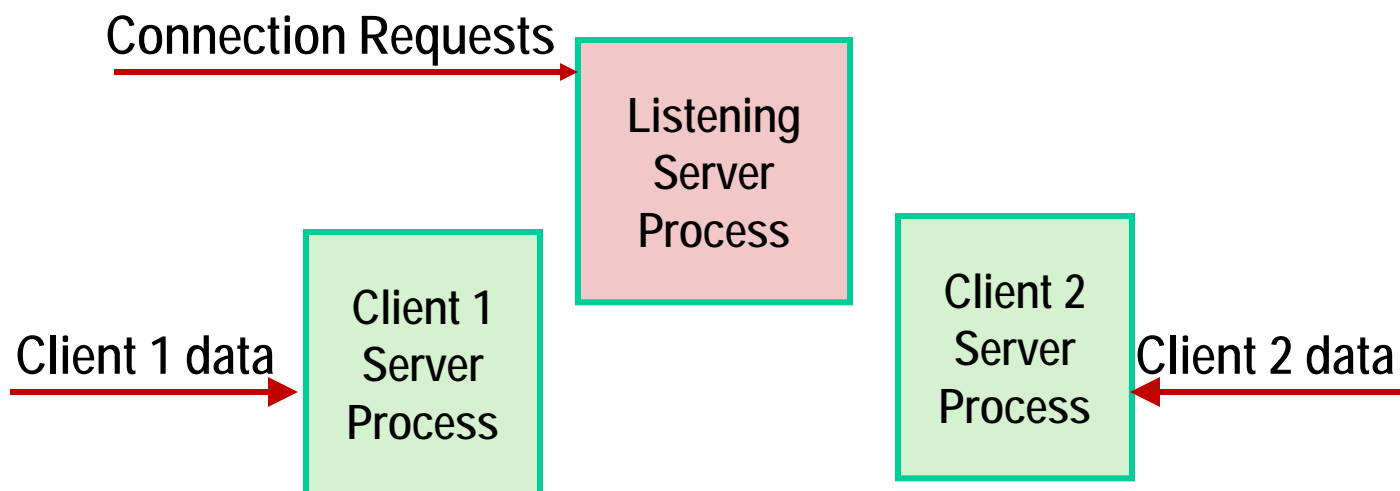

- Each client handled by independent process
- No shared state between them
- Both parent & child have copies of listenfd and connfd
 - Parent must close connfd
 - Child must close listenfd

Concurrent Server: `accept` Illustrated



1. Server blocks in `accept`, waiting for connection request on listening descriptor `listenfd`

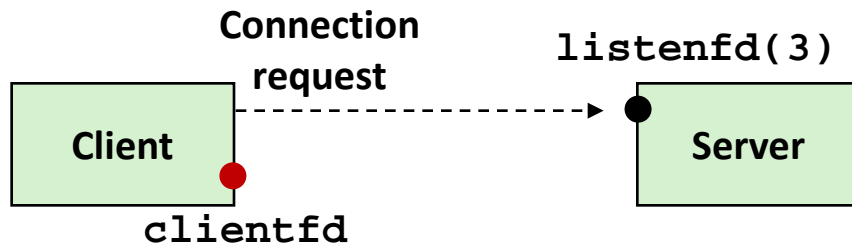

2. Client makes connection request by calling `connect`

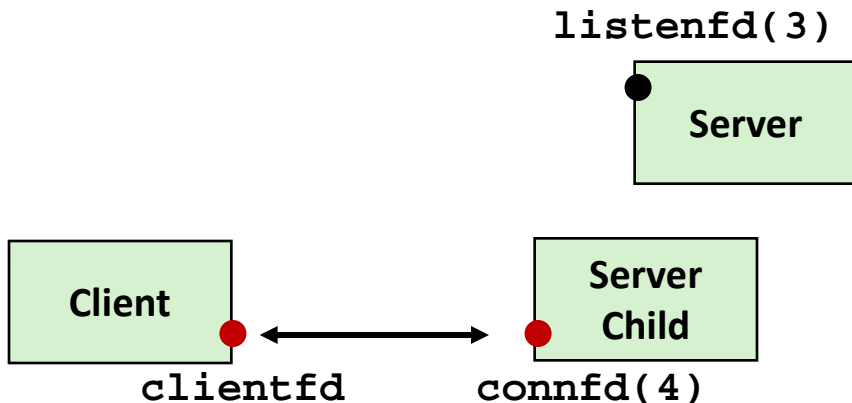

3. Server returns `connfd` from `accept`. Forks child to handle client. Connection is now established between `clientfd` and `connfd`

Implementation Must-dos With Process-Based Designs

- **Listening server process must reap zombie children**
 - to avoid fatal memory leak
- **Listening server process must close its copy of `connfd`**
 - Kernel keeps reference for each socket/open file
 - After fork, `refcnt(connfd) = 2`
 - Connection will not be closed until `refcnt(connfd) == 0`

Pros and Cons of Process-Based Designs

- **+ Handle multiple connections concurrently**
- **+ Clean sharing model**
 - descriptors (no)
 - file tables (yes)
 - global variables (no)
- **+ Simple and straightforward**
- **– Additional overhead for process control**
- **– Nontrivial to share data between processes**
 - Requires IPC (interprocess communication) mechanisms
 - FIFO's (named pipes), System V shared memory and semaphores

Approach #2: Multiple Threads

- **Very similar to approach #1 (multiple processes)**
 - but, with threads instead of processes

Traditional View of a Process

- **Process = process context + code, data, and stack**

Process context

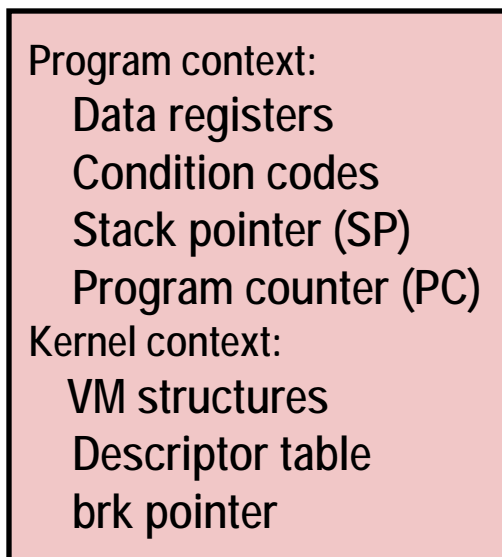

Code, data, and stack

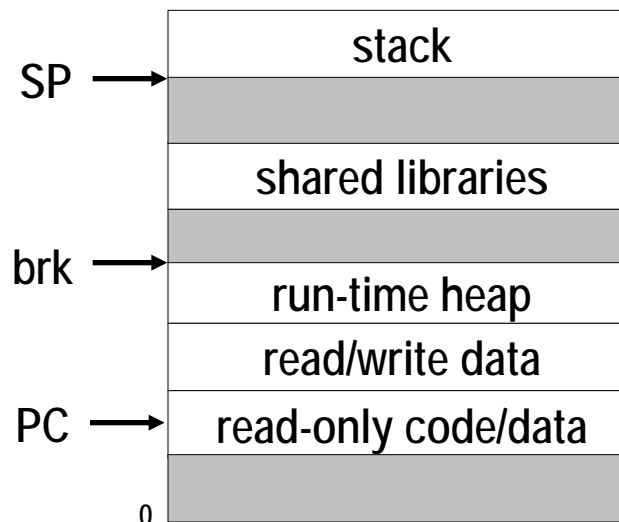

Alternate View of a Process

- Process = thread + code, data, and kernel context

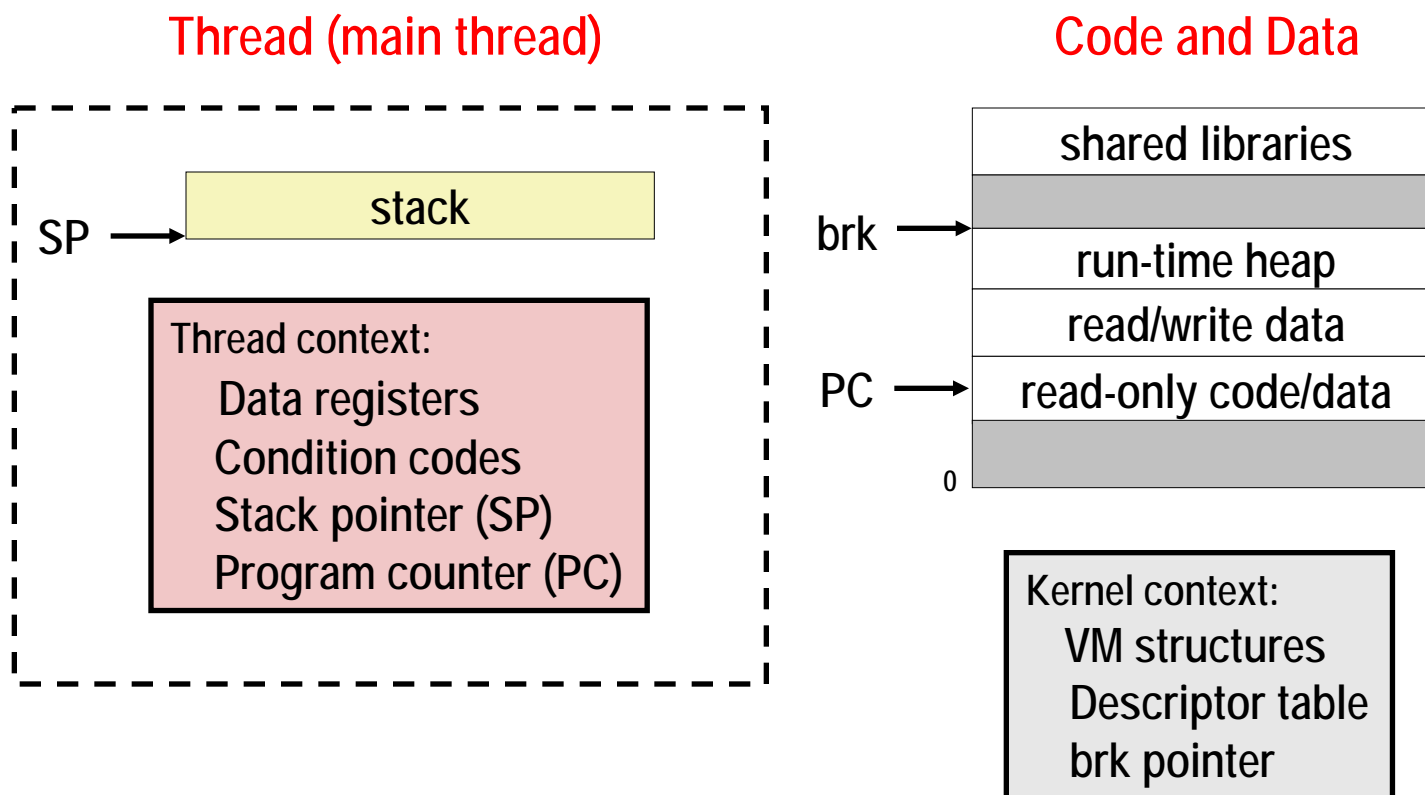

A Process With Multiple Threads

- **Multiple threads can be associated with a process**
 - Each thread has its own logical control flow
 - Each thread shares the same code, data, and kernel context
 - Share common virtual address space (inc. stacks)
 - Each thread has its own thread id (TID)

Thread 1 (main thread)

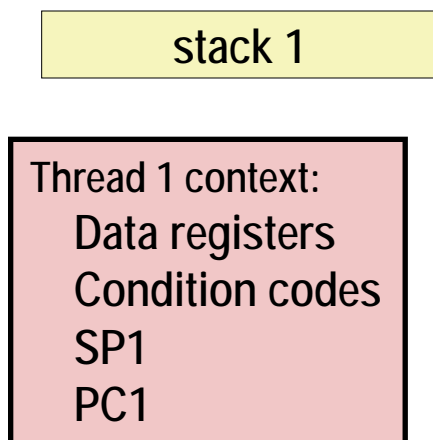

Shared code and data

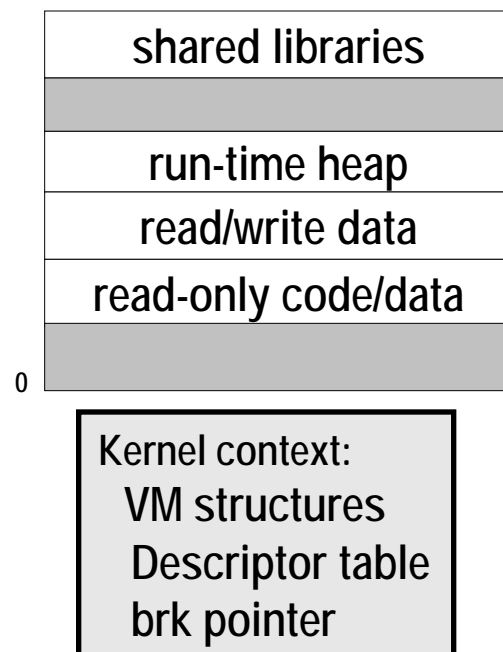

Thread 2 (peer thread)

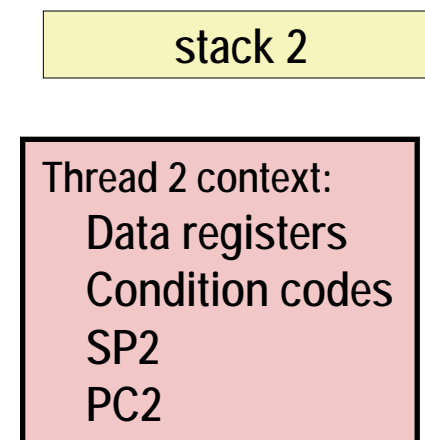

Logical View of Threads

- **Threads associated with process form a pool of peers**
 - Unlike processes which form a tree hierarchy

Threads associated with process foo

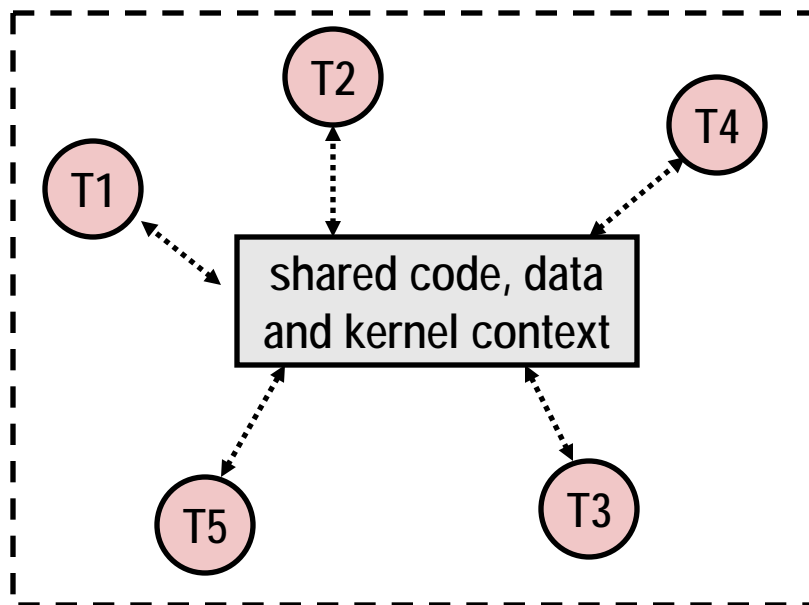

Process hierarchy

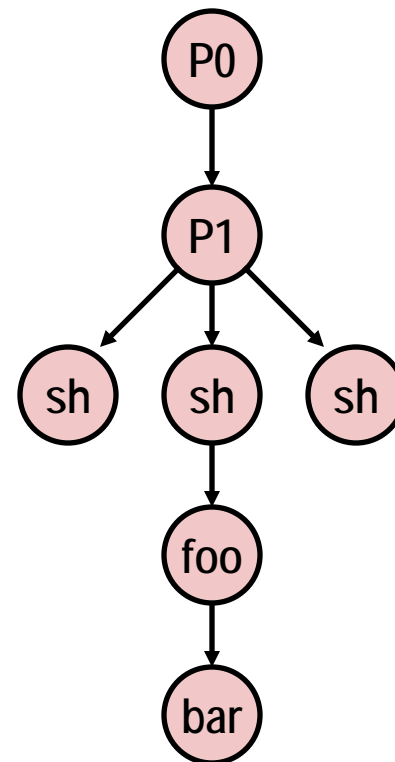

Thread Execution

■ Single Core Processor

- Simulate concurrency by time slicing

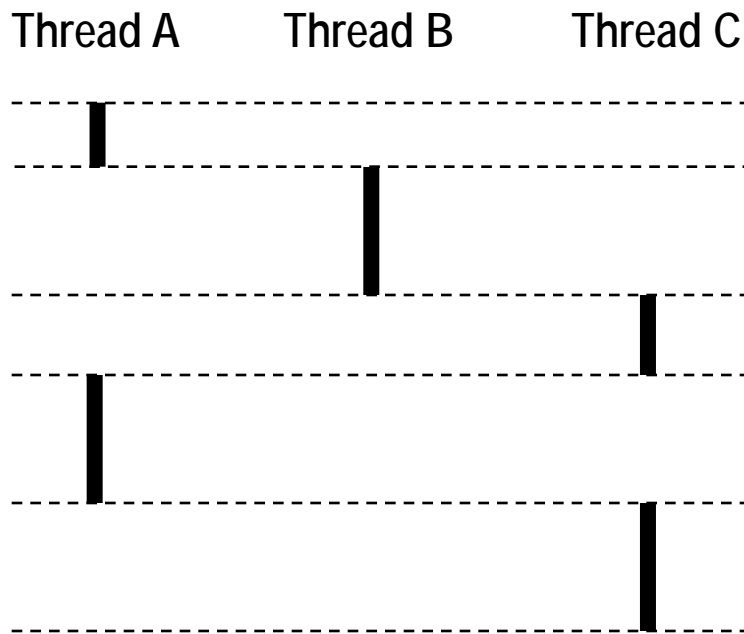

■ Multi-Core Processor

- Can have true concurrency

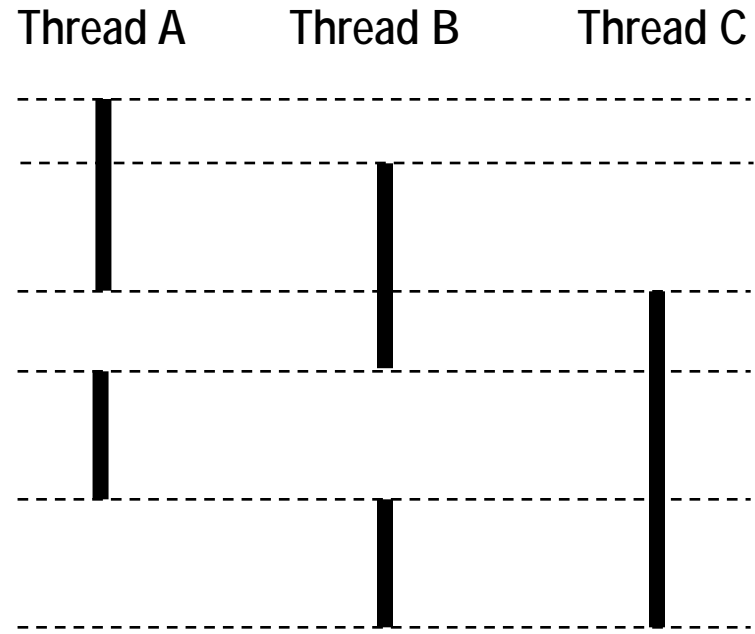

Run 3 threads on 2 cores

Logical Concurrency

- Two threads are (logically) concurrent if their flows overlap in time
- Otherwise, they are sequential

- **Examples:**

- Concurrent: A & B, A&C
- Sequential: B & C

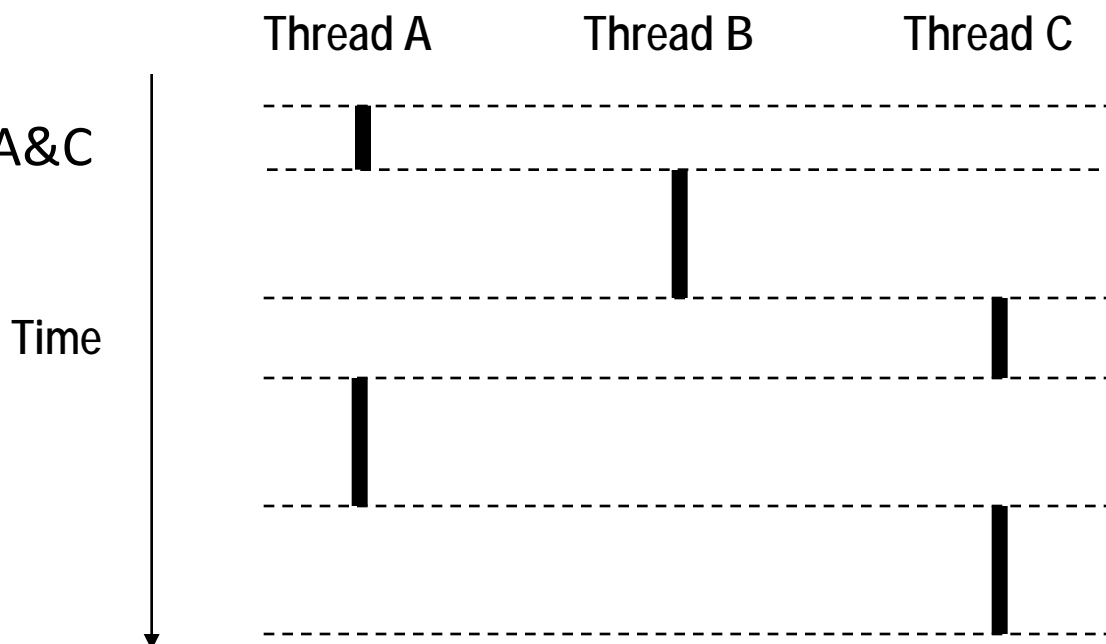

Threads vs. Processes

■ How threads and processes are similar

- Each has its own logical control flow
- Each can run concurrently with others (possibly on different cores)
- Each is context switched

■ How threads and processes are different

- Threads share code and some data
 - Processes (typically) do not
- Threads are somewhat less expensive than processes
 - Process control (creating and reaping) twice as expensive as thread control
 - Linux numbers:
 - ~20K cycles to create and reap a process
 - ~10K cycles (or less) to create and reap a thread

Posix Threads (Pthreads) Interface

- ***Pthreads*: Standard interface for ~60 functions that manipulate threads from C programs**
 - Creating and reaping threads
 - `pthread_create()`
 - `pthread_join()`
 - Determining your thread ID
 - `pthread_self()`
 - Terminating threads
 - `pthread_cancel()`
 - `pthread_exit()`
 - `exit()` [terminates all threads], `RET` [terminates current thread]
 - Synchronizing access to shared variables
 - `pthread_mutex_init`
 - `pthread_mutex_[un]lock`
 - `pthread_cond_init`
 - `pthread_cond_[timed]wait`

The Pthreads "hello, world" Program

```
/*
 * hello.c - Pthreads "hello, world" program
 */
#include "csapp.h"

void *thread(void *vargp);

int main() {
    pthread_t tid;

    Pthread_create(&tid, NULL, thread, NULL);
    Pthread_join(tid, NULL);
    exit(0);
}
```

*Thread attributes
(usually NULL)*

*Thread arguments
(void *p)*

*return value
(void **p)*

```
/* thread routine */
void *thread(void *vargp) {
    printf("Hello, world!\n");
    return NULL;
}
```

Execution of Threaded "hello, world"

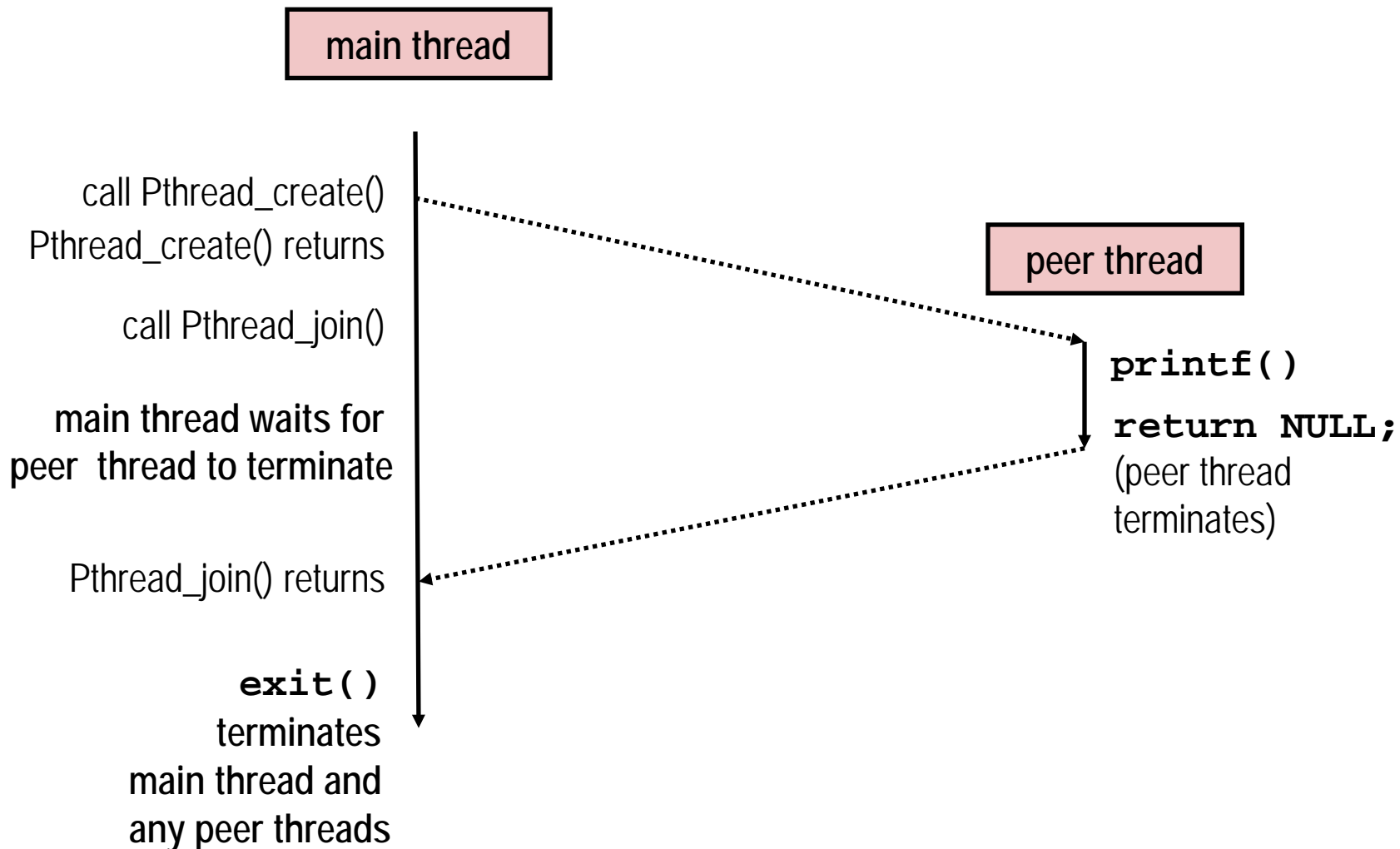

Thread-Based Concurrent Echo Server

```
int main(int argc, char **argv) {
    int port = atoi(argv[1]);
    struct sockaddr_in clientaddr;
    int clientlen=sizeof(clientaddr);
    pthread_t tid;

    int listenfd = Open_listenfd(port);
    while (1) {
        int *connfdp = Malloc(sizeof(int));
        *connfdp = Accept(listenfd,
                        (SA *) &clientaddr, &clientlen);
        Pthread_create(&tid, NULL, echo_thread, connfdp);
    }
}
```

- Spawn new thread for each client
- Pass it copy of connection file descriptor
- Note use of Malloc()
 - Without corresponding Free()

Thread-Based Concurrent Server (cont)

```
/* thread routine */
void *echo_thread(void *vargp)
{
    int connfd = *((int *)vargp);
    Pthread_detach(pthread_self());
    Free(vargp);
    echo(connfd);
    Close(connfd);
    return NULL;
}
```

- Run thread in “detached” mode
 - Runs independently of other threads
 - Reaped automatically (by kernel) when it terminates
- Free storage allocated to hold clientfd
 - “Producer-Consumer” model

Threaded Execution Model

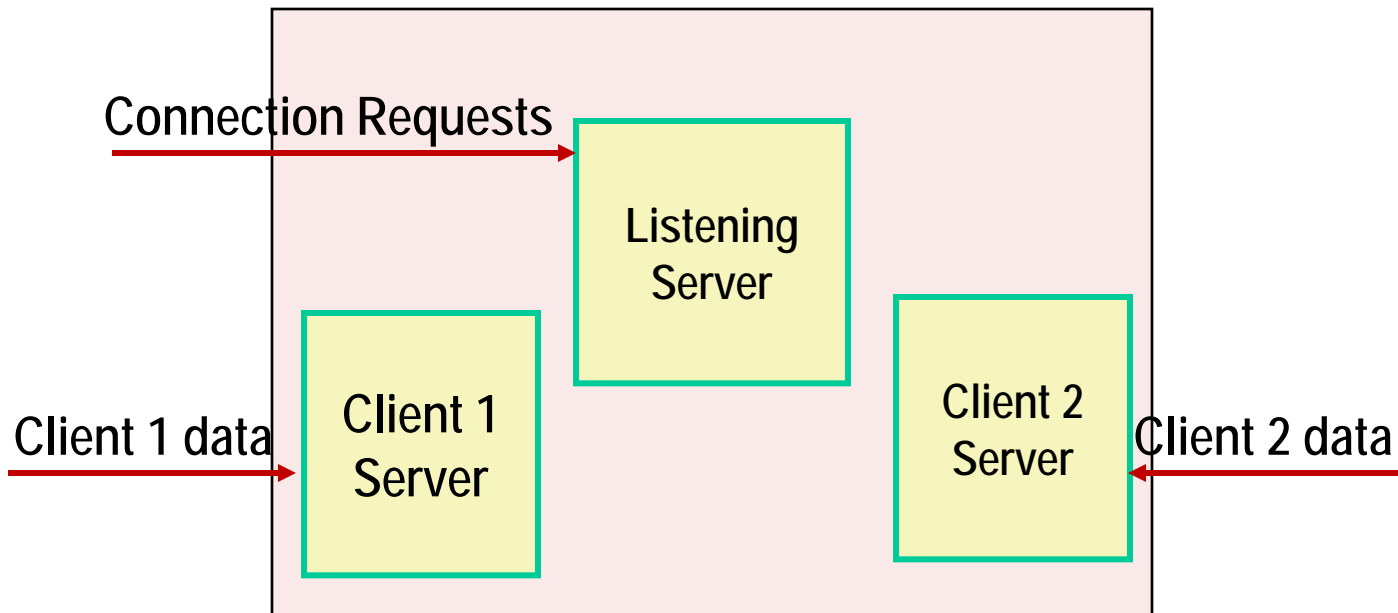

- Multiple threads within single process
- Some state between them
 - e.g., file descriptors

Potential Form of Unintended Sharing

```

while (1) {
    int connfd = Accept(listenfd, (SA *) &clientaddr, &clientlen);
    Pthread_create(&tid, NULL, echo_thread, (void *) &connfd);
}

```

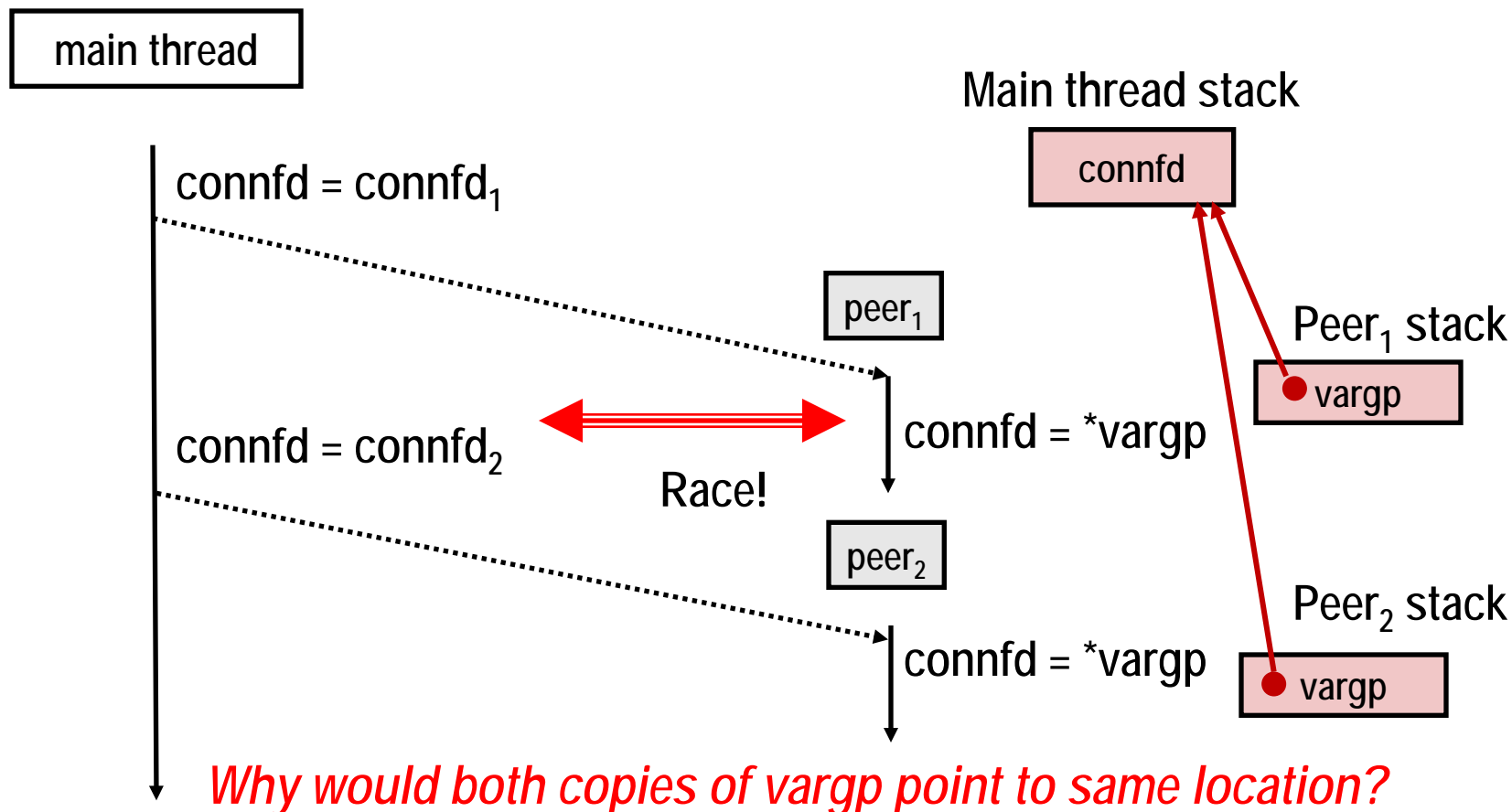

Could this race occur?

Main

```
int i;
for (i = 0; i < 100; i++) {
    Pthread_create(&tid, NULL,
                  thread, &i);
}
```

Thread

```
void *thread(void *vargp)
{
    int i = *((int *)vargp);
    Pthread_detach(pthread_self());
    save_value(i);
    return NULL;
}
```

■ Race Test

- If no race, then each thread would get different value of *i*
- Set of saved values would consist of one copy each of 0 through 99

Experimental Results

No Race

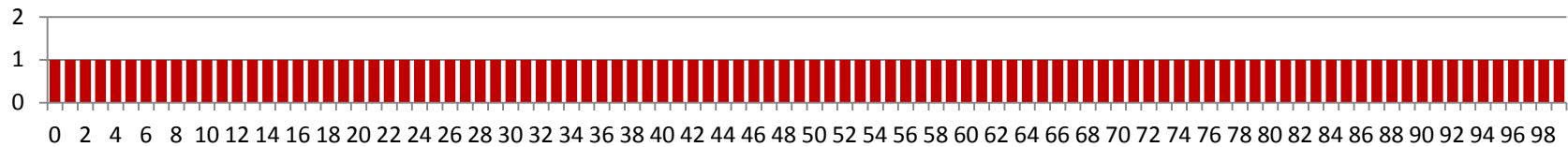

Single core laptop

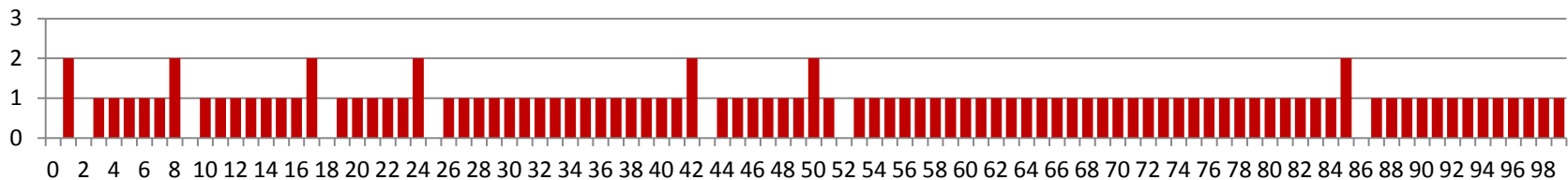

- Can the race really happen?

Experimental Results

No Race

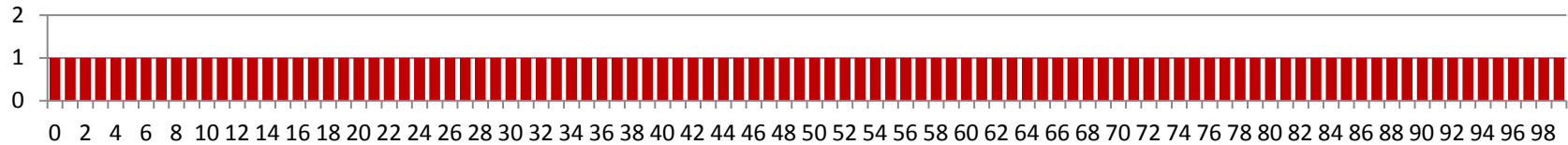

Single core laptop

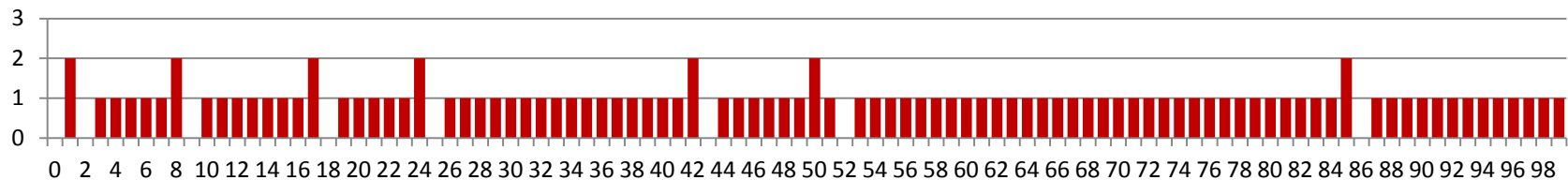

Multicore server

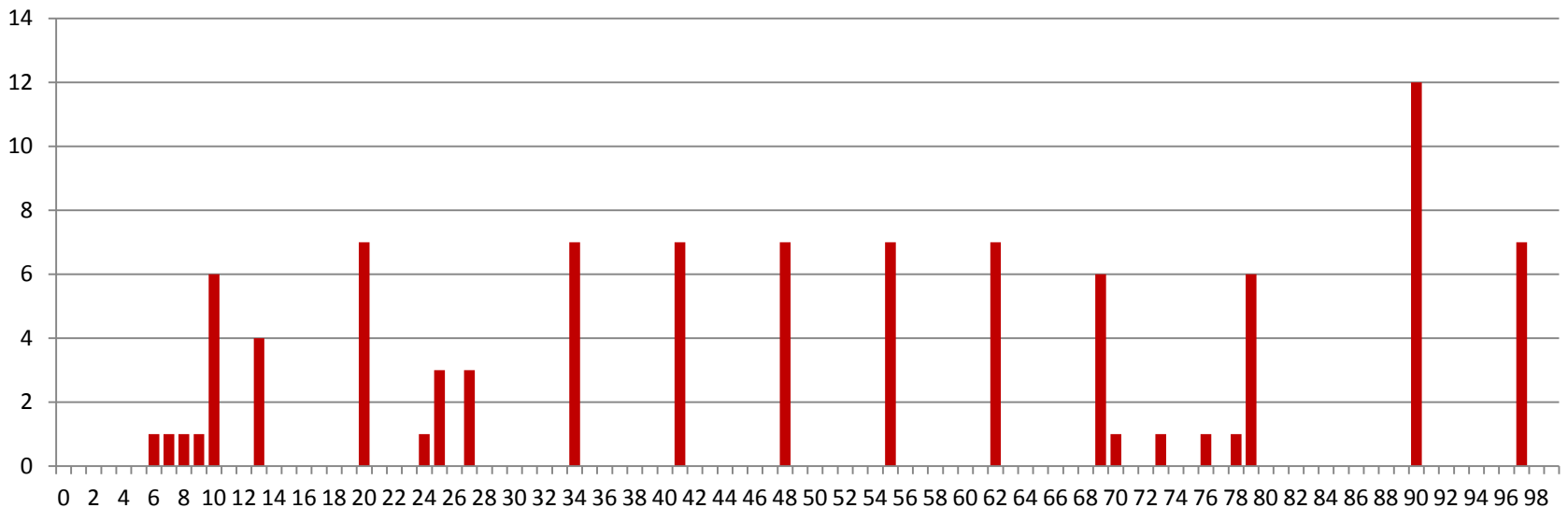

■ **Yes! The race can really happen!**

Issues With Thread-Based Servers

■ Must run “detached” to avoid memory leak

- At any point in time, a thread is either *joinable* or *detached*
- *Joinable* thread can be reaped and killed by other threads
 - must be reaped (with `pthread_join`) to free memory resources
- *Detached* thread cannot be reaped or killed by other threads
 - resources are automatically reaped on termination
- Default state is joinable
 - use `pthread_detach(pthread_self())` to make detached

■ Must be careful to avoid unintended sharing

- For example, passing pointer to main thread's stack
 - `pthread_create(&tid, NULL, thread, (void *)&connfd);`

■ All functions called by a thread must be *thread-safe*

- (next lecture)

Pros and Cons of Thread-Based Designs

- **+ Easy to share data structures between threads**
 - e.g., logging information, file cache
- **+ Threads are more efficient than processes**
- **– Unintentional sharing can introduce subtle and hard-to-reproduce errors!**
 - The ease with which data can be shared is both the greatest strength and the greatest weakness of threads
 - Hard to know which data shared & which private
 - Hard to detect by testing
 - Probability of bad race outcome very low
 - But nonzero!
 - Future lectures

Approaches to Concurrency

■ Processes

- Hard to share resources: Easy to avoid unintended sharing
- High overhead in adding/removing clients

■ Threads

- Easy to share resources: Perhaps too easy
- Medium overhead
- Not much control over scheduling policies
- Difficult to debug
 - Event orderings not repeatable

■ I/O Multiplexing

- Tedious and low level
- Total control over scheduling
- Very low overhead
- Cannot create as fine grained a level of concurrency
- Does not make use of multi-core

View from Server's TCP Manager

Client 1 Client 2 Server

```
srv> ./echoserverp 15213
```

```
c11> ./echoclient greatwhite.ics.cs.cmu.edu 15213
```

```
srv> connected to (128.2.192.34), port 50437
```

```
c12> ./echoclient greatwhite.ics.cs.cmu.edu 15213
```

```
srv> connected to (128.2.205.225), port 41656
```

Connection	Host	Port	Host	Port
Listening	---	---	128.2.220.10	15213
c11	128.2.192.34	50437	128.2.220.10	15213
c12	128.2.205.225	41656	128.2.220.10	15213

View from Server's TCP Manager

Connection	Host	Port	Host	Port
Listening	---	---	128.2.220.10	15213
c11	128.2.192.34	50437	128.2.220.10	15213
c12	128.2.205.225	41656	128.2.220.10	15213

■ Port Demultiplexing

- TCP manager maintains separate stream for each connection
 - Each represented to application program as socket
 - New connections directed to listening socket
 - Data from clients directed to one of the connection sockets