



Bits, Bytes, and Integers – Part 2

15-213/18-213/15-513/18-613: Introduction to Computer Systems
3rd Lecture, February 9, 2021

Summary From Last Lecture

- **Representing information as bits**
- **Bit-level manipulations**
- **Integers**
 - **Representation: unsigned and signed**
 - **Conversion, casting**
 - **Expanding, truncating**
 - **Addition, negation, multiplication, shifting**
- **Representations in memory, pointers, strings**
- **Summary**

Encoding Integers

Unsigned

$$B2U(X) = \sum_{i=0}^{w-1} x_i \cdot 2^i$$

Two's Complement

$$B2T(X) = -x_{w-1} \cdot 2^{w-1} + \sum_{i=0}^{w-2} x_i \cdot 2^i$$

Sign Bit



Two's Complement Examples (w = 5)

	-16	8	4	2	1	
10 =	0	1	0	1	0	

$$8+2 = 10$$

	-16	8	4	2	1	
-10 =	1	0	1	1	0	

$$-16+4+2 = -10$$

Unsigned & Signed Numeric Values

X	$B2U(X)$	$B2T(X)$
0000	0	0
0001	1	1
0010	2	2
0011	3	3
0100	4	4
0101	5	5
0110	6	6
0111	7	7
1000	8	-8
1001	9	-7
1010	10	-6
1011	11	-5
1100	12	-4
1101	13	-3
1110	14	-2
1111	15	-1

■ Equivalence

- Same encodings for nonnegative values

■ Uniqueness

- Every bit pattern represents unique integer value
- Each representable integer has unique bit encoding

■ Expression containing signed and unsigned int:

`int` is cast to `unsigned`

Sign Extension and Truncation

■ Sign Extension

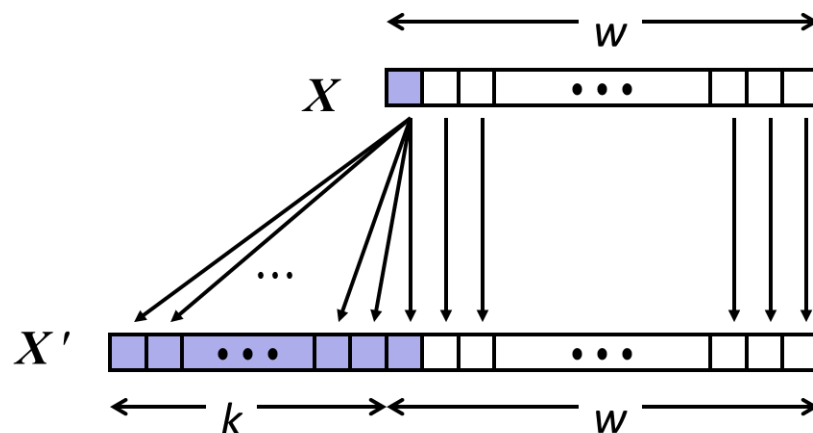

■ Truncation

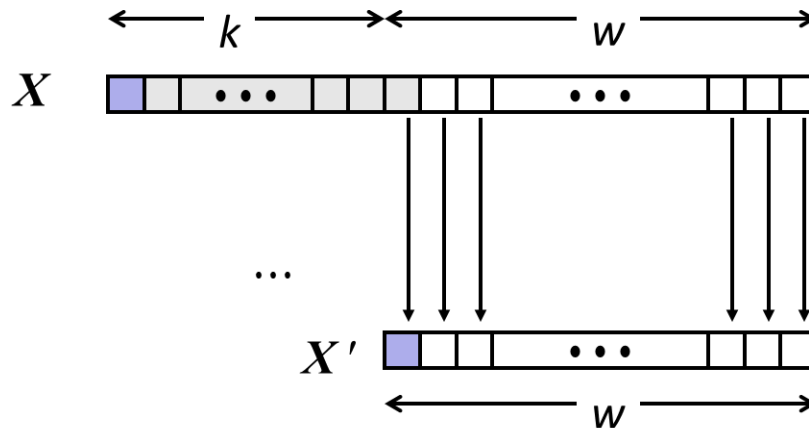

Global Thermonuclear War

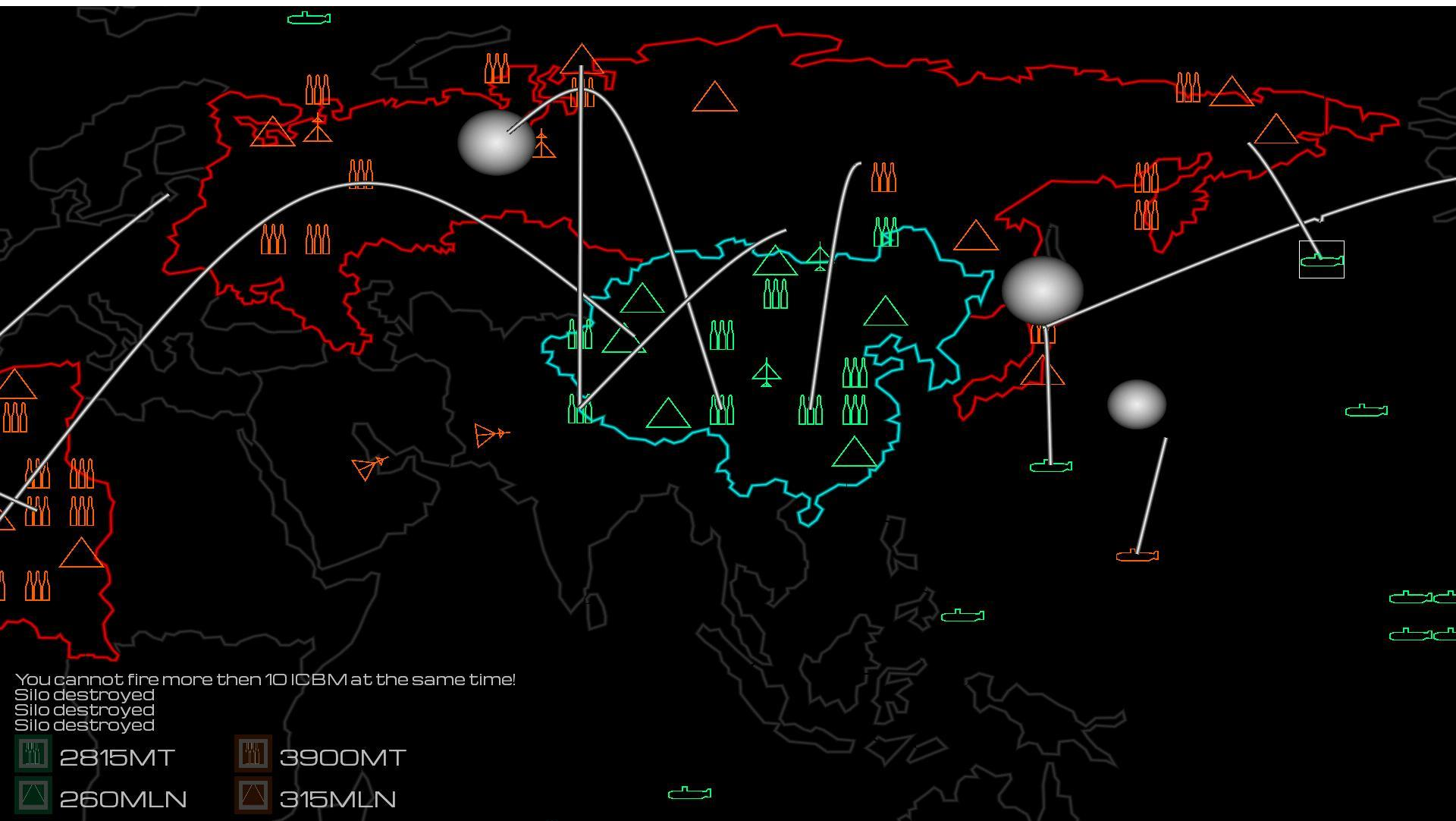

- **Misunderstanding integers can lead to the end of the world as we know it!**
- Thule (Qaanaaq), Greenland
- US DoD “Site J” Ballistic Missile Early Warning System (BMEWS)
- 10/5/60: world nearly ends
- Missile radar echo: 1/8s
- BMEWS reports: 75s echo(!)
- 1000s of objects reported
- NORAD alert level 5:
 - Immediate incoming nuclear attack!!!!



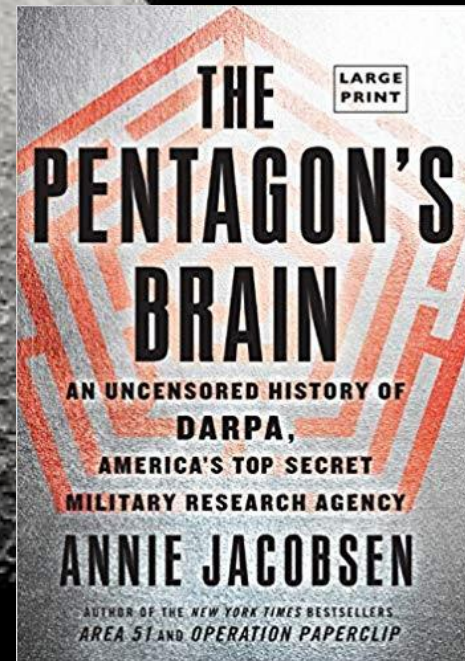

- **Kruschev was in NYC 10/5/60 (weird time to attack)**
 - someone in Qaanaaq said “why not go check outside?”
- **“Missiles” were actually THE MOON RISING OVER NORWAY**
- **Expected max distance: 3000 mi; Moon distance: .25M miles!**
- **.25M miles % sizeof(distance) = 2200mi.**
- **Overflow of distance nearly caused nuclear apocalypse!!**

Today: Bits, Bytes, and Integers

- Representing information as bits
- Bit-level manipulations
- **Integers**
 - Representation: unsigned and signed
 - Conversion, casting
 - Expanding, truncating
 - **Addition, negation, multiplication, shifting**
- Representations in memory, pointers, strings
- Summary

Unsigned Addition

Operands: w bits

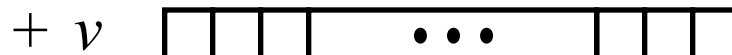

True Sum: $w+1$ bits

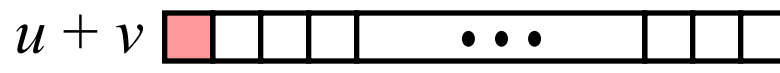

Discard Carry: w bits



■ Standard Addition Function

- Ignores carry output

■ Implements Modular Arithmetic

$$s = \text{UAdd}_w(u, v) = u + v \bmod 2^w$$

unsigned char	1110 1001	E9	223
	+ 1101 0101	+ D5	+ 213
	1 1011 1110	1BE	446
	1011 1110	BE	190

	Hex	Decimal	Binary
0	0	0000	
1	1	0001	
2	2	0010	
3	3	0011	
4	4	0100	
5	5	0101	
6	6	0110	
7	7	0111	
8	8	1000	
9	9	1001	
A	10	1010	
B	11	1011	
C	12	1100	
D	13	1101	
E	14	1110	
F	15	1111	

Visualizing (Mathematical) Integer Addition

■ Integer Addition

- 4-bit integers u, v
- Compute true sum $\text{Add}_4(u, v)$
- Values increase linearly with u and v
- Forms planar surface

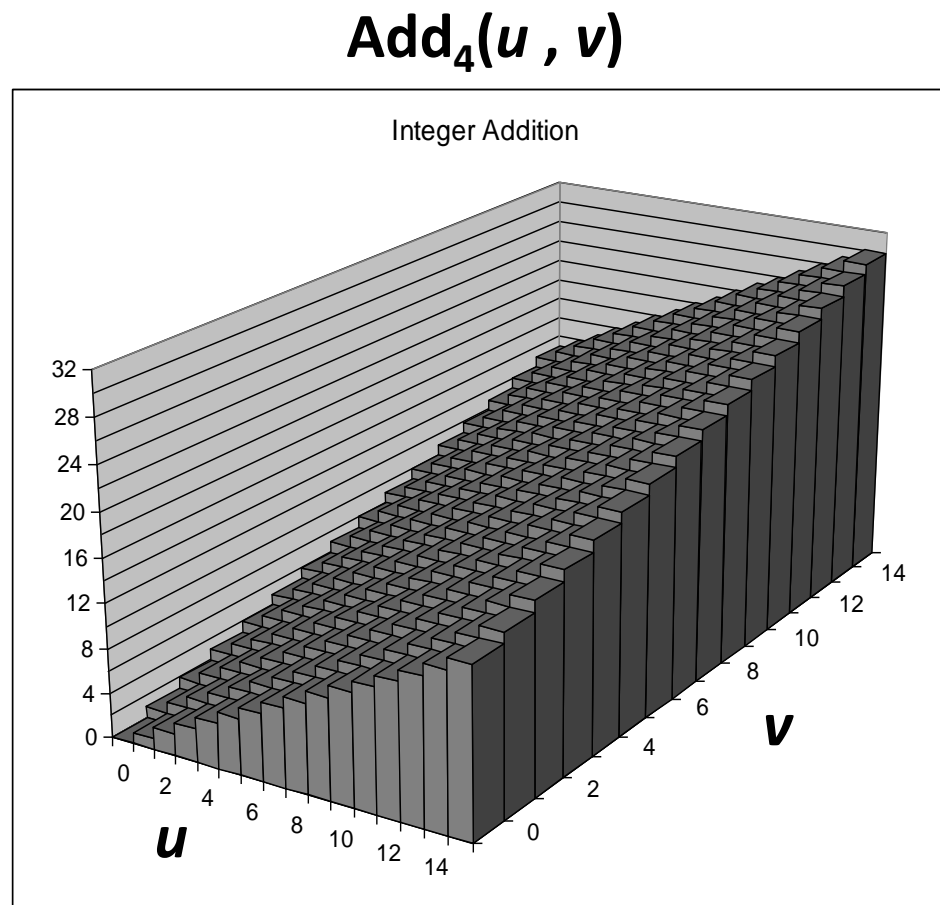

Visualizing Unsigned Addition

■ Wraps Around

- If true sum $\geq 2^w$
- At most once

True Sum

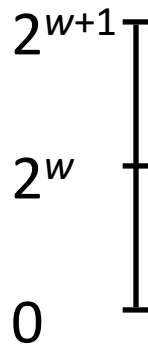

Overflow

Modular Sum

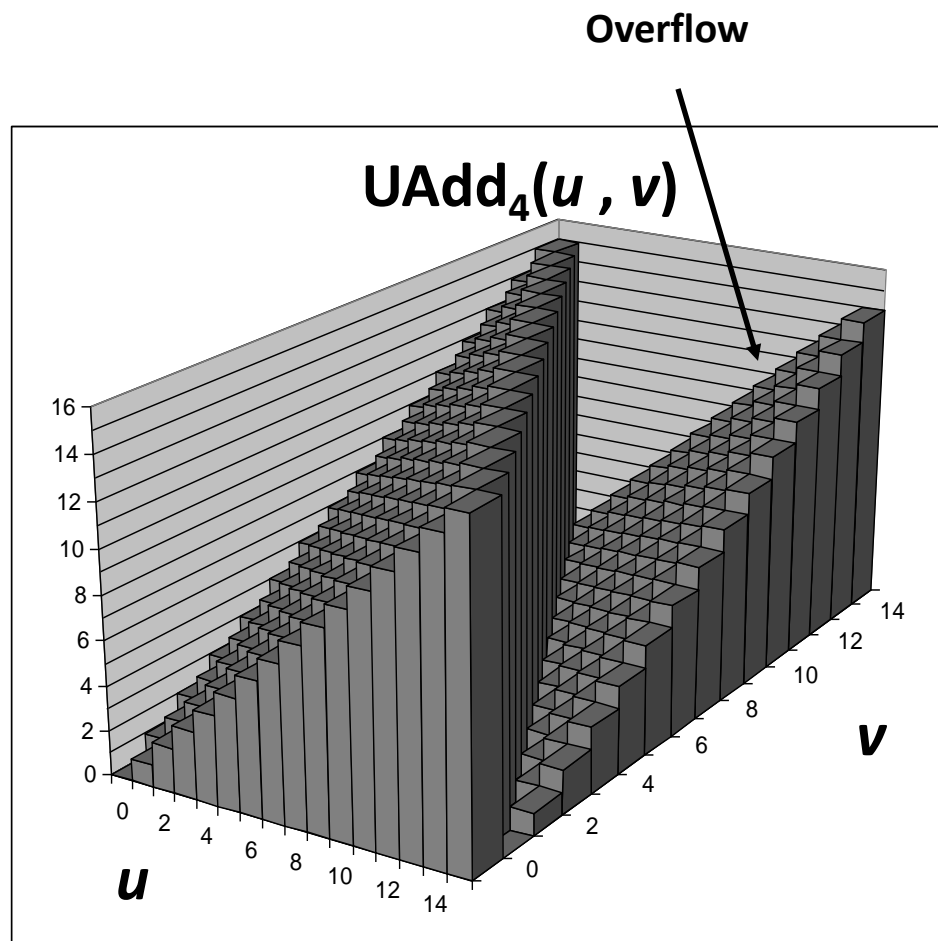

Two's Complement Addition

Operands: w bits

u 

+ v 

True Sum: $w+1$ bits

$u + v$ 

Discard Carry: w bits

$\text{TAdd}_w(u, v)$ 

■ TAdd and UAdd have Identical Bit-Level Behavior

- Signed vs. unsigned addition in C:

```
int s, t, u, v;
```

```
s = (int) ((unsigned) u + (unsigned) v);
```

```
t = u + v
```

- Will give `s == t`

1110 1001	E9	-23
+ 1101 0101	+ D5	+ -43
1 1011 1110	1BE	-66
1011 1110	BE	-66

TAdd Overflow

■ Functionality

- True sum requires $w+1$ bits
- Drop off MSB
- Treat remaining bits as 2's comp. integer

0 111...1

0 100...0
0 011...1

0 000...0

1 100...0
1 011...1

1 000...0

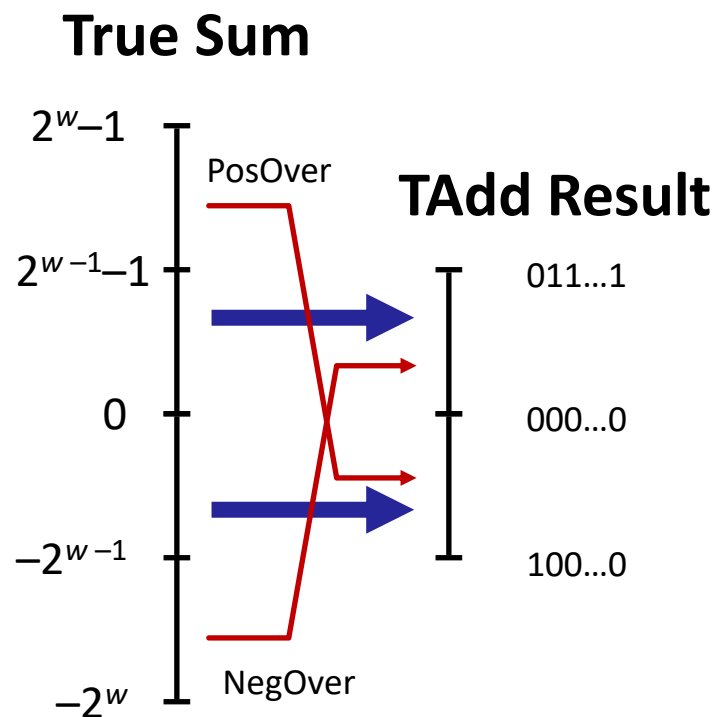

Visualizing 2's Complement Addition

■ Values

- 4-bit two's comp.
- Range from -8 to +7

■ Wraps Around

- If $\text{sum} \geq 2^{w-1}$
 - Becomes negative
 - At most once
- If $\text{sum} < -2^{w-1}$
 - Becomes positive
 - At most once

NegOver

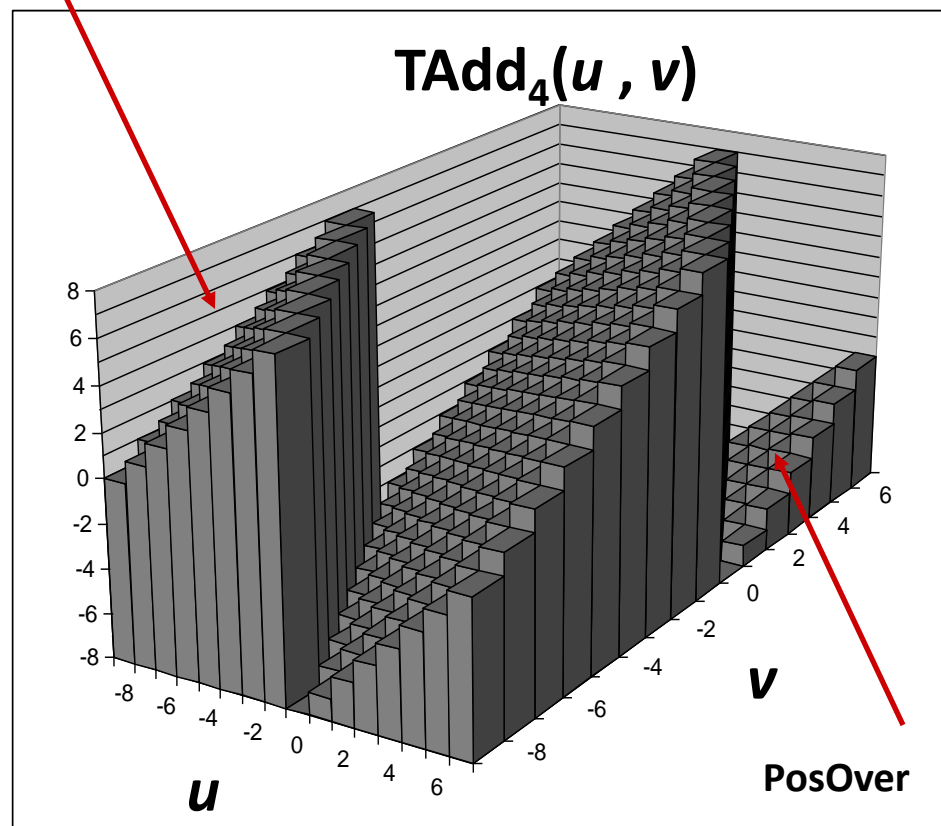

Characterizing TAdd

■ Functionality

- True sum requires $w+1$ bits
- Drop off MSB
- Treat remaining bits as 2's comp. integer

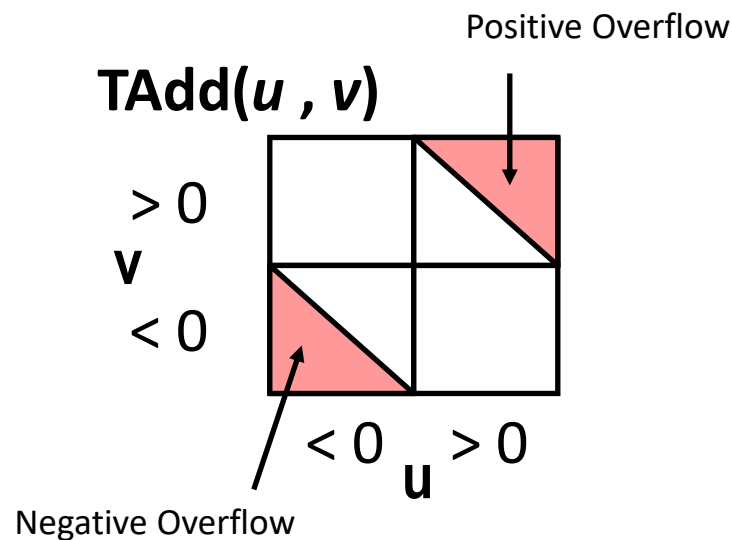

$$TAdd_w(u, v) = \begin{cases} u + v + 2^w & u + v < TMin_w \text{ (NegOver)} \\ u + v & TMin_w \leq u + v \leq TMax_w \\ u + v - 2^w & TMax_w < u + v \text{ (PosOver)} \end{cases}$$

Multiplication

- **Goal: Computing Product of w -bit numbers x, y**
 - Either signed or unsigned
- **But, exact results can be bigger than w bits**
 - Unsigned: up to $2w$ bits
 - Result range: $0 \leq x * y \leq (2^w - 1)^2 = 2^{2w} - 2^{w+1} + 1$
 - Two's complement min (negative): Up to $2w-1$ bits
 - Result range: $x * y \geq (-2^{w-1}) * (2^{w-1} - 1) = -2^{2w-2} + 2^{w-1}$
 - Two's complement max (positive): Up to $2w$ bits, but only for $(TMin_w)^2$
 - Result range: $x * y \leq (-2^{w-1})^2 = 2^{2w-2}$
- **So, maintaining exact results...**
 - would need to keep expanding word size with each product computed
 - is done in software, if needed
 - e.g., by “arbitrary precision” arithmetic packages

Unsigned Multiplication in C

Operands: w bits



True Product: $2 * w$ bits



Discard w bits: w bits



■ Standard Multiplication Function

- Ignores high order w bits

■ Implements Modular Arithmetic

$$\text{UMult}_w(u, v) = u \cdot v \bmod 2^w$$

$$\begin{array}{r}
 1110 \ 1001 \\
 * \ 1101 \ 0101 \\
 \hline
 1100 \ 0001 \ 1101 \ 1101 \\
 \hline
 1101 \ 1101
 \end{array}$$

$$\begin{array}{r}
 \text{E9} \\
 * \ \text{D5} \\
 \hline
 \text{C1DD} \\
 \hline
 \text{DD}
 \end{array}$$

$$\begin{array}{r}
 233 \\
 * \ 213 \\
 \hline
 49629 \\
 \hline
 221
 \end{array}$$

Signed Multiplication in C

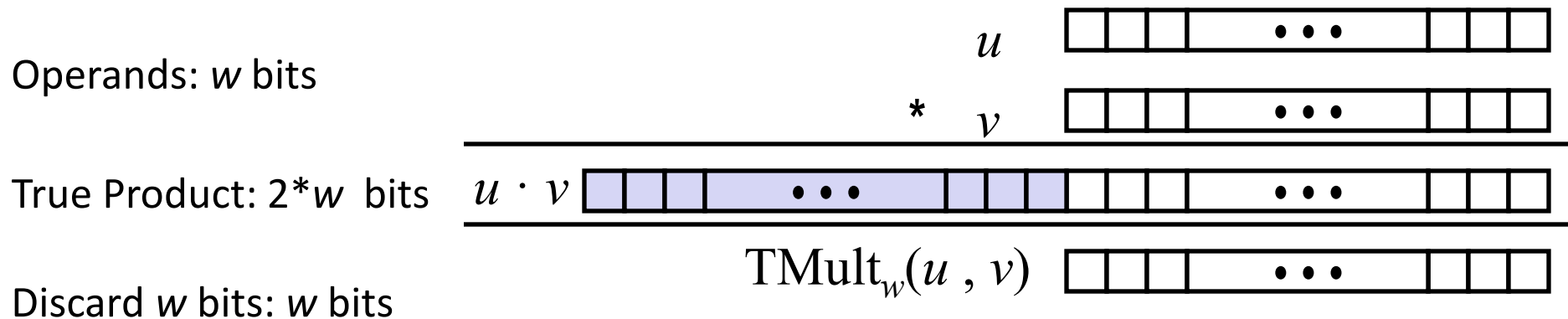

■ Standard Multiplication Function

- Ignores high order w bits
- Some of which are different for signed vs. unsigned multiplication
- Lower bits are the same

	1110 1001	E9	-23
*	1101 0101	* D5	* -43
	0000 0011 1101 1101	03DD	989
	1101 1101	DD	-35

Power-of-2 Multiply with Shift

■ Operation

- $u \ll k$ gives $u * 2^k$
- Both signed and unsigned

Operands: w bits

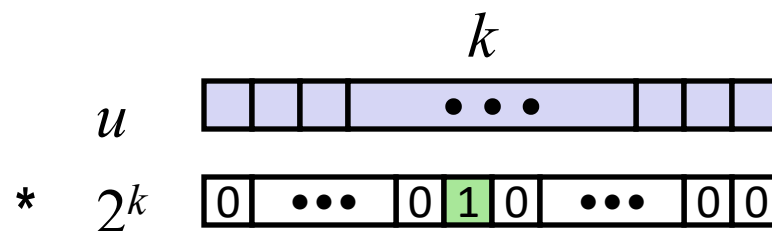

True Product: $w+k$ bits

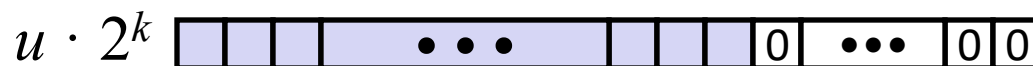

Discard k bits: w bits

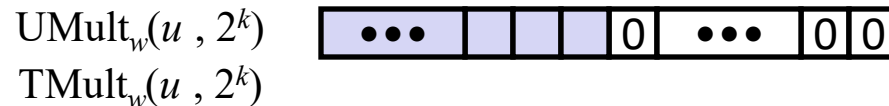

■ Examples

- $u \ll 3 \quad == \quad u * 8$
- $(u \ll 5) - (u \ll 3) == \quad u * 24$
- Most machines shift and add faster than multiply
 - Compiler generates this code automatically

Unsigned Power-of-2 Divide with Shift

■ Quotient of Unsigned by Power of 2

- $u \gg k$ gives $\lfloor u / 2^k \rfloor$
- Uses logical shift

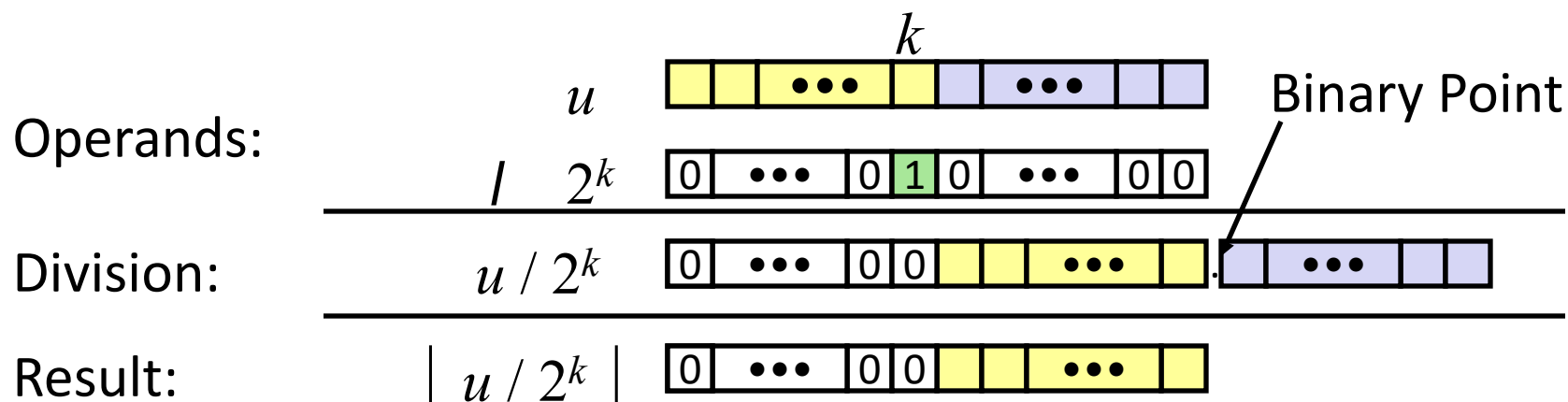

	Division	Computed	Hex	Binary
x	15213	15213	3B 6D	00111011 01101101
x >> 1	7606.5	7606	1D B6	00011101 10110110
x >> 4	950.8125	950	03 B6	00000011 10110110
x >> 8	59.4257813	59	00 3B	00000000 00111011

Signed Power-of-2 Divide with Shift

■ Quotient of Signed by Power of 2

- $x \gg k$ gives $\lfloor x / 2^k \rfloor$
- Uses arithmetic shift
- Rounds wrong direction when $x < 0$

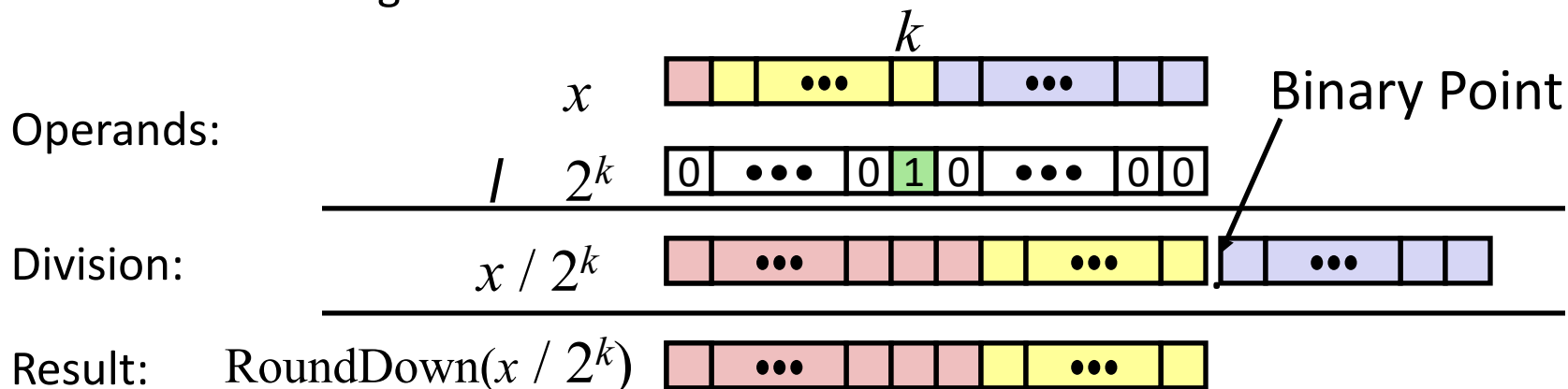

	Division	Computed	Hex	Binary
x	-15213	-15213	C4 93	11000100 10010011
$x \gg 1$	-7606.5	-7607	E2 49	1 1100010 01001001
$x \gg 4$	-950.8125	-951	FC 49	1111 1100 01001001
$x \gg 8$	-59.4257813	-60	FF C4	11111111 11000100

Correct Power-of-2 Divide

■ Quotient of Negative Number by Power of 2

- Want $\lceil \mathbf{x} / 2^k \rceil$ (Round Toward 0)
- Compute as $\lfloor (\mathbf{x} + 2^k - 1) / 2^k \rfloor$
 - In C: $(\mathbf{x} + (1 \ll k) - 1) \gg k$
 - Biases dividend toward 0

Case 1: No rounding

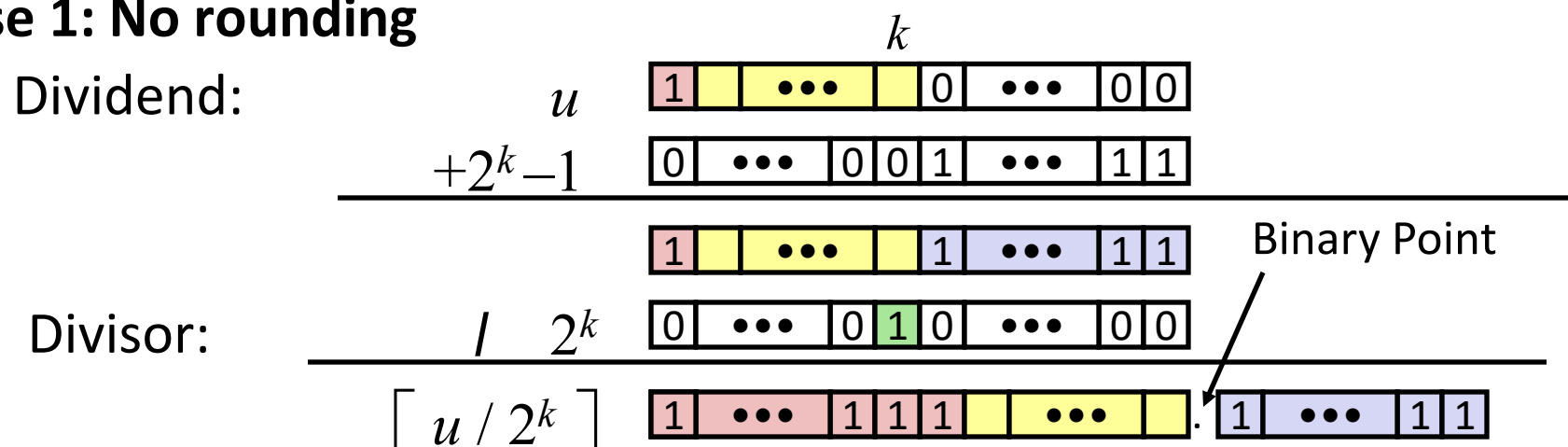

Biassing has no effect

Correct Power-of-2 Divide (Cont.)

Case 2: Rounding

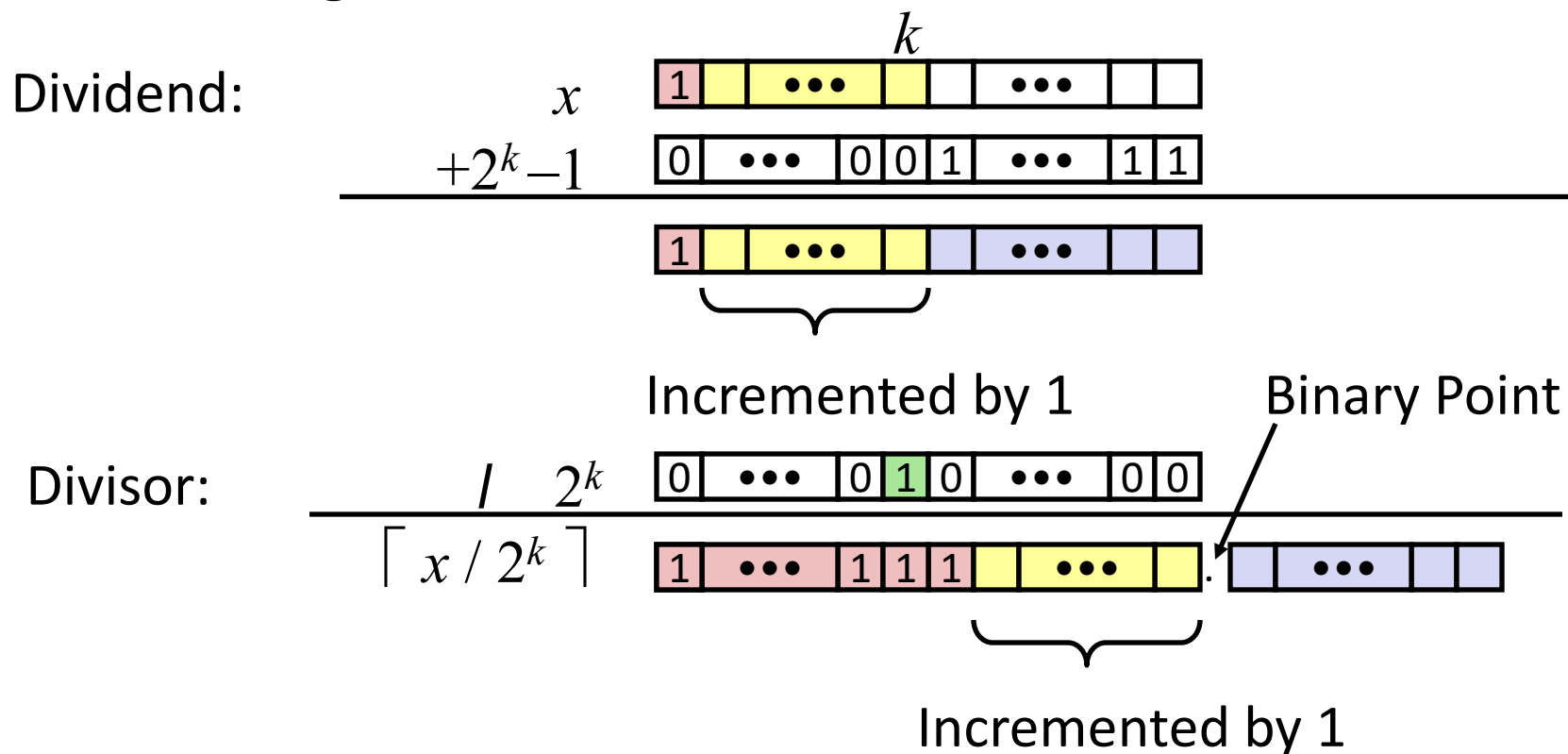

Biasing adds 1 to final result

Negation: Complement & Increment

■ Negate through complement and increase

$$\sim x + 1 == -x$$

■ Example

- Observation: $\sim x + x == 1111\dots111 == -1$

$$\begin{array}{r}
 x \quad \boxed{10011101} \\
 + \quad \sim x \quad \boxed{01100010} \\
 \hline
 -1 \quad \boxed{11111111}
 \end{array}$$

x = 15213

	Decimal	Hex	Binary
x	15213	3B 6D	00111011 01101101
~x	-15214	C4 92	11000100 10010010
~x+1	-15213	C4 93	11000100 10010011
y	-15213	C4 93	11000100 10010011

Complement & Increment Examples

$x = 0$

	Decimal	Hex	Binary
0	0	00 00	00000000 00000000
~ 0	-1	FF FF	11111111 11111111
$\sim 0 + 1$	0	00 00	00000000 00000000

$x = \text{TMin}$

	Decimal	Hex	Binary
x	-32768	80 00	10000000 00000000
$\sim x$	32767	7F FF	01111111 11111111
$\sim x + 1$	-32768	80 00	10000000 00000000

Canonical counter example

Today: Bits, Bytes, and Integers

- Representing information as bits
- Bit-level manipulations
- **Integers**
 - Representation: unsigned and signed
 - Conversion, casting
 - Expanding, truncating
 - Addition, negation, multiplication, shifting
 - **Summary**
- Representations in memory, pointers, strings

Arithmetic: Basic Rules

■ Addition:

- Unsigned/signed: Normal addition followed by truncate, same operation on bit level
- Unsigned: addition mod 2^w
 - Mathematical addition + possible subtraction of 2^w
- Signed: modified addition mod 2^w (result in proper range)
 - Mathematical addition + possible addition or subtraction of 2^w

■ Multiplication:

- Unsigned/signed: Normal multiplication followed by truncate, same operation on bit level
- Unsigned: multiplication mod 2^w
- Signed: modified multiplication mod 2^w (result in proper range)

Quiz Time!

Check out:

<https://canvas.cmu.edu/courses/17808>

Today: Bits, Bytes, and Integers

- Representing information as bits
- Bit-level manipulations
- Integers
 - Representation: unsigned and signed
 - Conversion, casting
 - Expanding, truncating
 - Addition, negation, multiplication, shifting
 - Summary
- **Representations in memory, pointers, strings**

Byte-Oriented Memory Organization

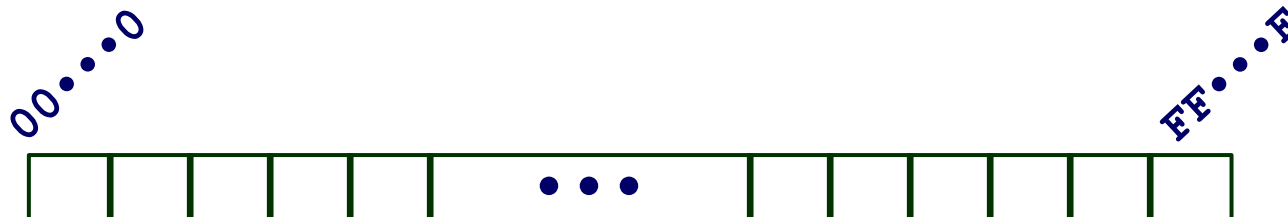

■ Programs refer to data by address

- Conceptually, envision it as a very large array of bytes
 - In reality, it's not, but can think of it that way
- An address is like an index into that array
 - and, a pointer variable stores an address

■ Note: system provides private address spaces to each “process”

- Think of a process as a program being executed
- So, a program can clobber its own data, but not that of others

Machine Words

- **Any given computer has a “Word Size”**
 - Nominal size of integer-valued data
 - and of addresses
 - Until recently, most machines used 32 bits (4 bytes) as word size
 - Limits addresses to 4GB (2^{32} bytes)
 - Increasingly, machines have 64-bit word size
 - Potentially, could have 18 EB (exabytes) of addressable memory
 - That's 18.4×10^{18}
 - Machines still support multiple data formats
 - Fractions or multiples of word size
 - Always integral number of bytes

Word-Oriented Memory Organization

■ Addresses Specify Byte Locations

- Address of first byte in word
- Addresses of successive words differ by 4 (32-bit) or 8 (64-bit)

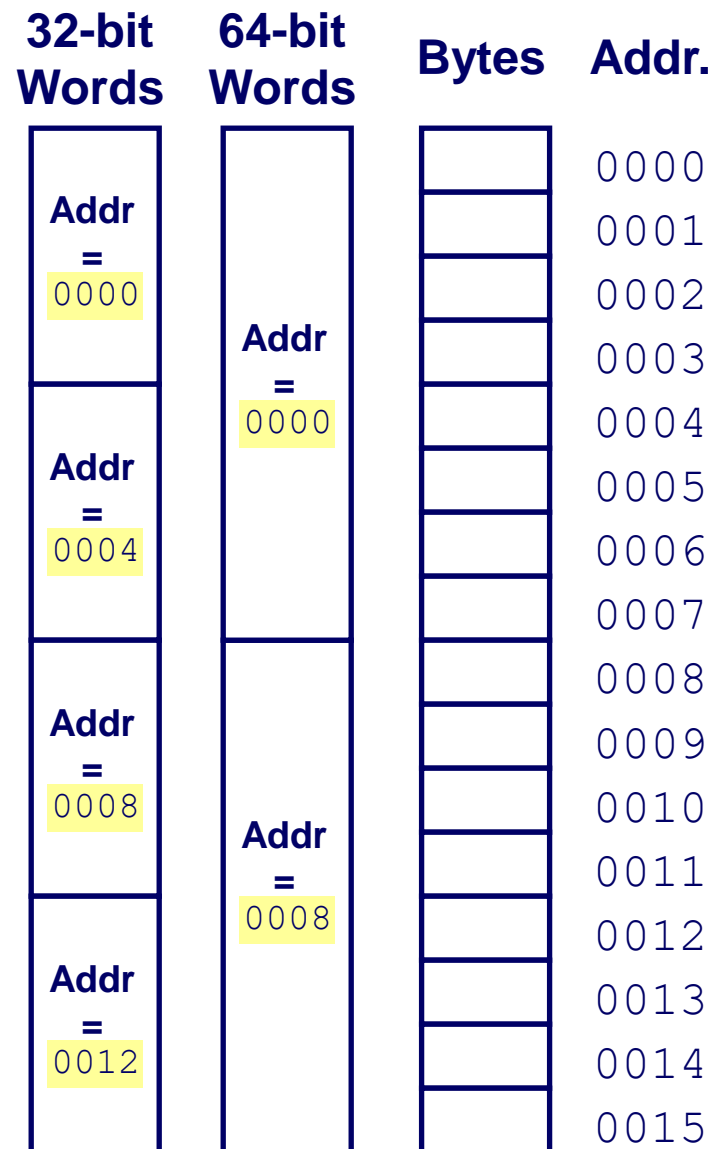

Example Data Representations

C Data Type	Typical 32-bit	Typical 64-bit	x86-64
<code>char</code>	1	1	1
<code>short</code>	2	2	2
<code>int</code>	4	4	4
<code>long</code>	4	8	8
<code>float</code>	4	4	4
<code>double</code>	8	8	8
<code>pointer</code>	4	8	8

Byte Ordering

- So, how are the bytes within a multi-byte word ordered in memory?
- Conventions
 - Big Endian: Sun (Oracle SPARC), PPC Mac, *Internet*
 - Least significant byte has highest address
 - Little Endian: *x86*, ARM processors running Android, iOS, and Linux
 - Least significant byte has lowest address

Byte Ordering Example

■ Example

- Variable x has 4-byte value of 0x01234567
- Address given by &x is 0x100

Big Endian

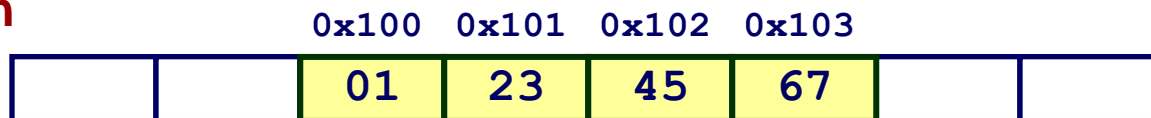

Little Endian

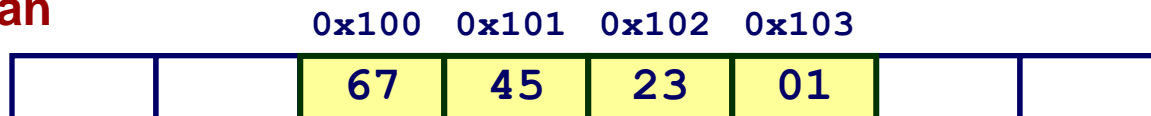

Representing Integers

Decimal: 15213

Binary: 0011 1011 0110 1101

Hex: 3 B 6 D

`int A = 15213;`

Increasing addresses
↓

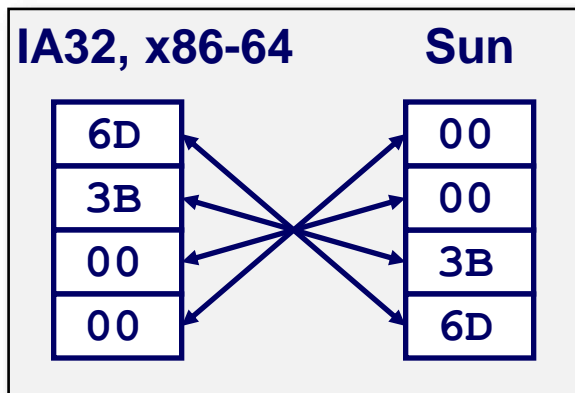

`long int C = 15213;`

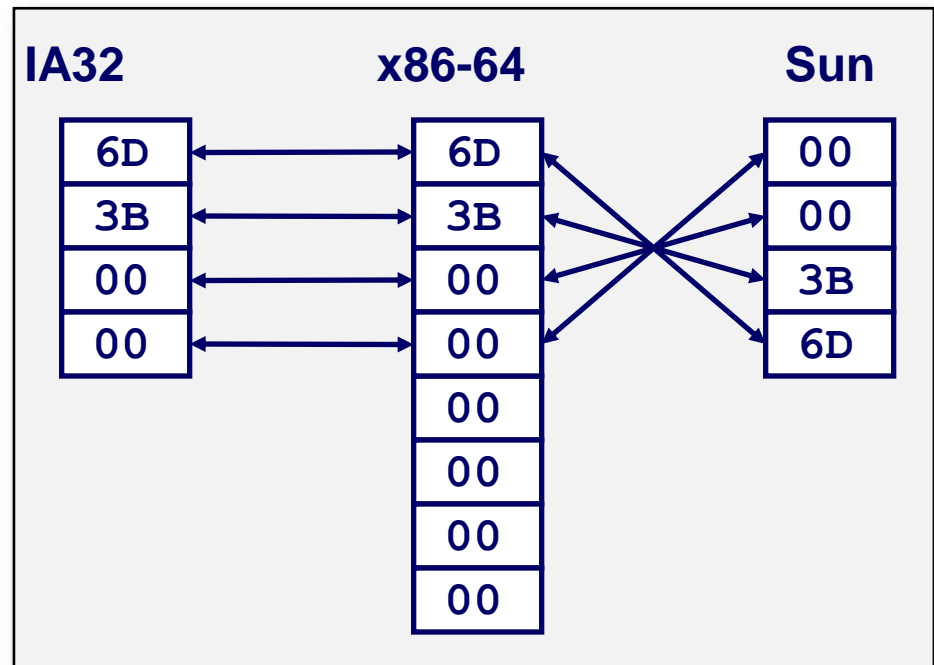

`int B = -15213;`

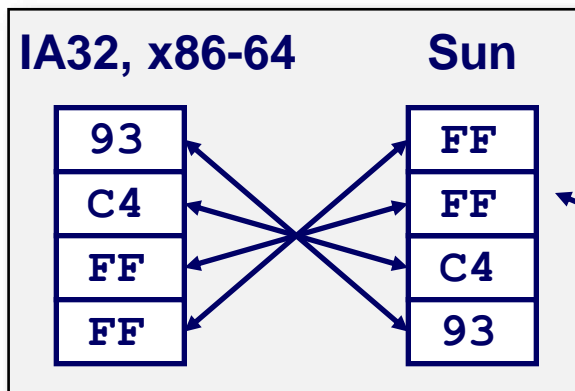

Two's complement representation

Examining Data Representations

■ Code to Print Byte Representation of Data

- Casting pointer to unsigned char * allows treatment as a byte array

```
typedef unsigned char *pointer;

void show_bytes(pointer start, size_t len){
    size_t i;
    for (i = 0; i < len; i++)
        printf("%p\t0x%.2x\n", start+i, start[i]);
    printf("\n");
}
```

Printf directives:

%p: Print pointer

%x: Print Hexadecimal

show_bytes Execution Example

```
int a = 15213;
printf("int a = 15213;\n");
show_bytes((pointer) &a, sizeof(int));
```

Result (Linux x86-64):

```
int a = 15213;
0x7ffffb7f71dbc    6d
0x7ffffb7f71dbd    3b
0x7ffffb7f71dbe    00
0x7ffffb7f71dbf    00
```

Representing Pointers

```
int B = -15213;  
int *P = &B;
```

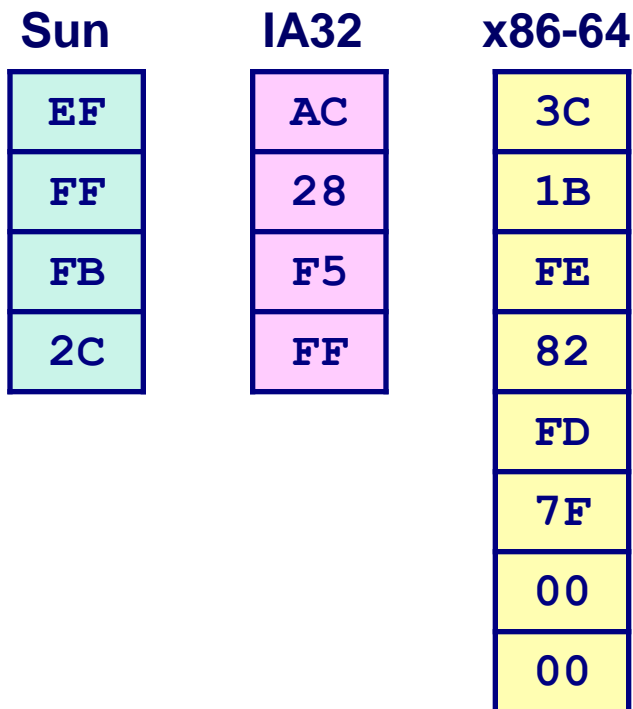

Different compilers & machines assign different locations to objects

Even get different results each time run program

Representing Strings

```
char S[6] = "18213";
```

■ Strings in C

- Represented by array of characters
- Each character encoded in ASCII format
 - Standard 7-bit encoding of character set
 - Character "0" has code 0x30
 - Digit i has code $0x30+i$
- String should be null-terminated
 - Final character = 0

■ Compatibility

- Byte ordering not an issue

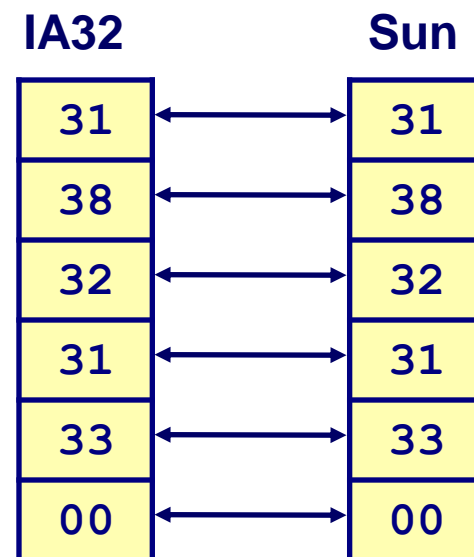

Reading Byte-Reversed Listings

■ Disassembly

- Text representation of binary machine code
- Generated by program that reads the machine code

■ Example Fragment

Address	Instruction Code	Assembly Rendition
8048365:	5b	pop %ebx
8048366:	81 c3 ab 12 00 00	add \$0x12ab, %ebx
804836c:	83 bb 28 00 00 00 00	cmpl \$0x0, 0x28(%ebx)

■ Deciphering Numbers

- Value: 0x12ab
- Pad to 32 bits: 0x000012ab
- Split into bytes: 00 00 12 ab
- Reverse: ab 12 00 00

Summary

- **Representing information as bits**
- **Bit-level manipulations**
- **Integers**
 - **Representation: unsigned and signed**
 - **Conversion, casting**
 - **Expanding, truncating**
 - **Addition, negation, multiplication, shifting**
- **Representations in memory, pointers, strings**
- **Summary**