

15-294 Rapid Prototyping Technologies

Instructor: Dave Touretzky



Teaching Assistants:



Saranya Vijayakumar



Lohith Tummala



Vicky Zou



Johnny Tian

15-294: Rapid Prototyping Technologies

- Computer Aided Design (Solidworks)
- Laser Cutting & 3D Printing
- Algorithms and file formats
- Open source movement and maker culture
- Industry trends
- Societal impacts
- Actually make stuff!

Half-semester mini: 5 units

Mon/Wed 7:00 - 8:20 PM
Hunt Library Studio A

Prof: Dave Touretzky



Three Goals for The Course

1. Learn how to **make stuff**.

- CAD tools (mainly SolidWorks)
- Laser cutting
- 3D printing (FDM)

2. Learn how the **underlying technology** works.

- File formats (DXF, STL), G-Code, slicing algorithms

3. Learn about how new additive manufacturing (3D printing) industries are developing and **impacting our economy**.

Communication

- The syllabus and all assignments are posted on the course web page.
- We will use **Piazza** for announcements, question answering, and discussions.
- If you have questions about an assignment, SolidWorks, etc., **use Piazza** instead of email.
 - Other students may have the same question.
 - Fellow students may be able to answer your question more quickly than the instructor or TA.

Attendance

- We expect you to be present for lectures.
- Please remember to sign the attendance sheet during each class.
- Attendance is 10% of your grade.
- You can miss up to 3 classes without penalty. Excused absences (e.g., illness with documentation, or attending a research conference at a professor's request) don't count against your total.

Grading

• Fabrication Projects		55%
– #1 Spirograph	10%	
– #2 Trees	15%	
– #3 Molecule	15%	
– #4 Duck rendering	15%	
• Presentations		10%
– Technology	5%	
– Materials	5%	
• Attendance		10%
• Final Project		25%
• No exams.		
		<hr/>
		100%

Hand-Ins

- Each assignment specifies what to hand in.
- We will use AutoLab to:
 - Accept hand-ins
 - Provide feedback on assignments
 - Record grades
- Assignments are due at 11:59 pm. Check the syllabus or Autolab for the due date.
- Hand-ins can be up to 2 days late, at a penalty of 1 point per day.

Office Hours

In the Hunt basement, near the laser cutters.

- Lohith: Mondays 2:00 – 3:00 in Hunt
- Saranya: Tuesdays 10:00 – 11:00 in GHC 6013
- Johnny: Tuesdays 12:00 – 1:00 in Hunt
- Vicky: Fridays 1:30 – 2:30 in Hunt
- Dave: by appointment.

Computer Access and Software

- We'll be using SolidWorks and Inkscape.
- You will need SolidWorks next lecture.
- To install the software on your personal laptop, see the Software Setup page linked from the course home page and syllabus page.
- SolidWorks is also available on Virtual Andrew.
- Install it now (or try Virtual Andrew now) so you have time to deal with any technical issues.

Fabrication

- You will be doing your own laser cutting.
 - Take laser cutter instruction online. The links are in the class schedule for the first day.
 - Sign up on BioRaft fire extinguisher training, which is done in person.
- You will have access to TechSpark so you can use their laser cutters as well as the IDeATe laser cutters.

Collaboration

- All course work should be done by yourself.
- You can ask anyone for help with SolidWorks or general advice about how to approach an assignment, but the work you hand in should be yours alone.
- If you build on someone else's work for a project (e.g., modify something from Thingiverse), acknowledge your sources!

What We'll Do Today

- Overview of rapid prototyping, laser cutting, and 3D printing.

Do this after class (takes one minute):

- Sign up for fire extinguisher training if you have not already been certified.

What Is Rapid Prototyping?

- Use CAD tools to quickly design an object, render it, check for interferences, simulate its motion, and more!
- Use computer-controlled machinery to fabricate your object quickly and largely automatically.
- Many technologies available:
 - 2D planar parts: laser cutting, water jet
 - Complex shapes: 3D printing, CNC router

Non-Rapid Fabrication Technologies

- Require skill to operate
- Potential for injury
- Potential for tool damage
- May entail lengthy preparation or high setup costs.
- Offer a wider range of materials.
- Can be optimized for mass production.

Planar Operations



Band Saw



Drill Press

Manual Machining



Milling Machine

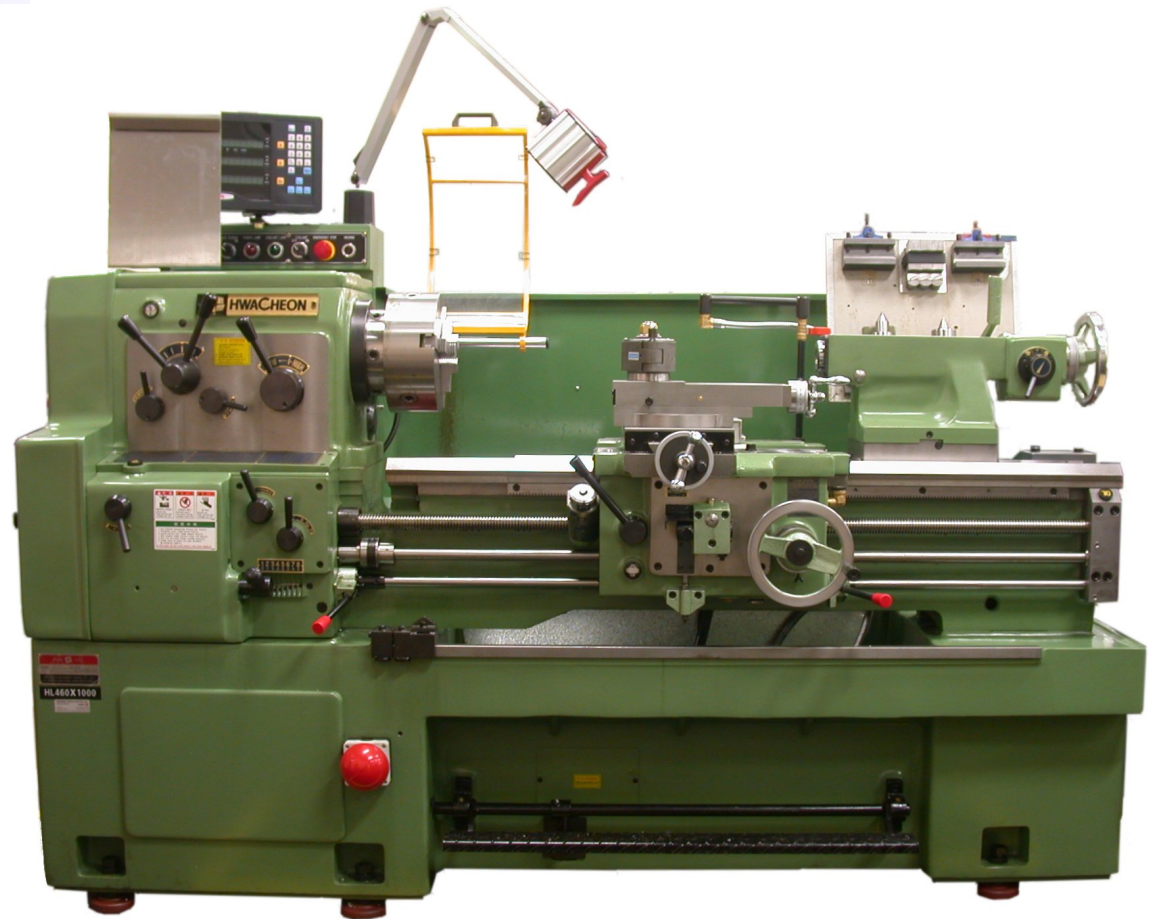

Lathe

CNC Machining



Injection Molding

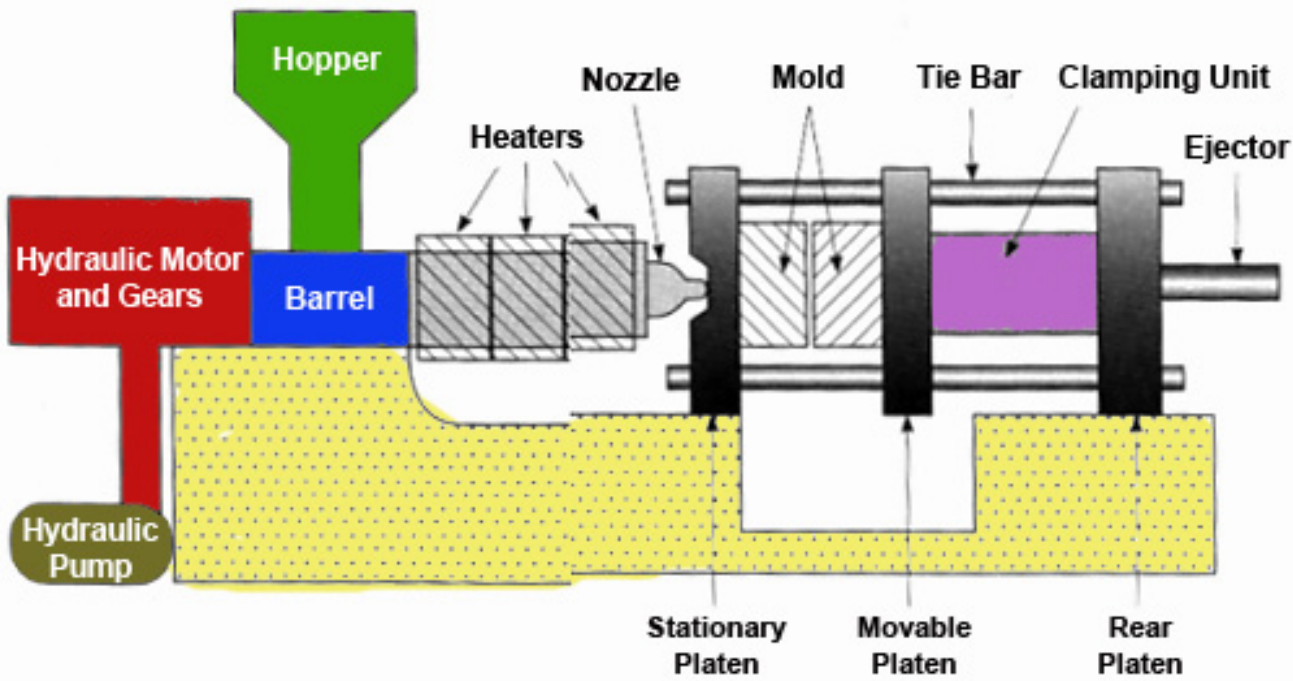

Molded Part

Final Part

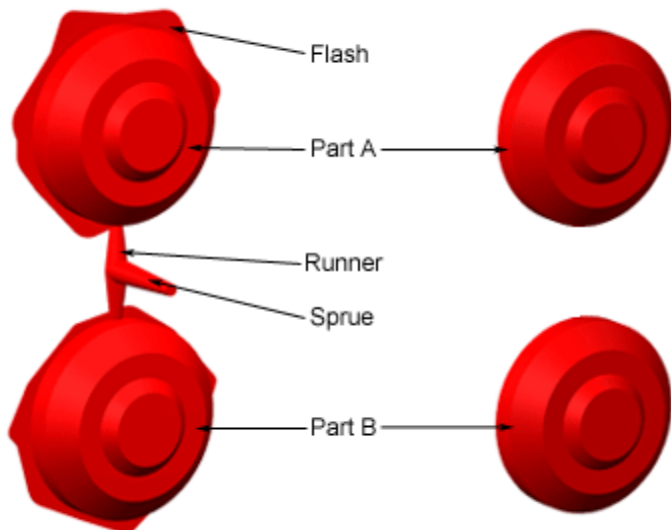

Vacuum Forming

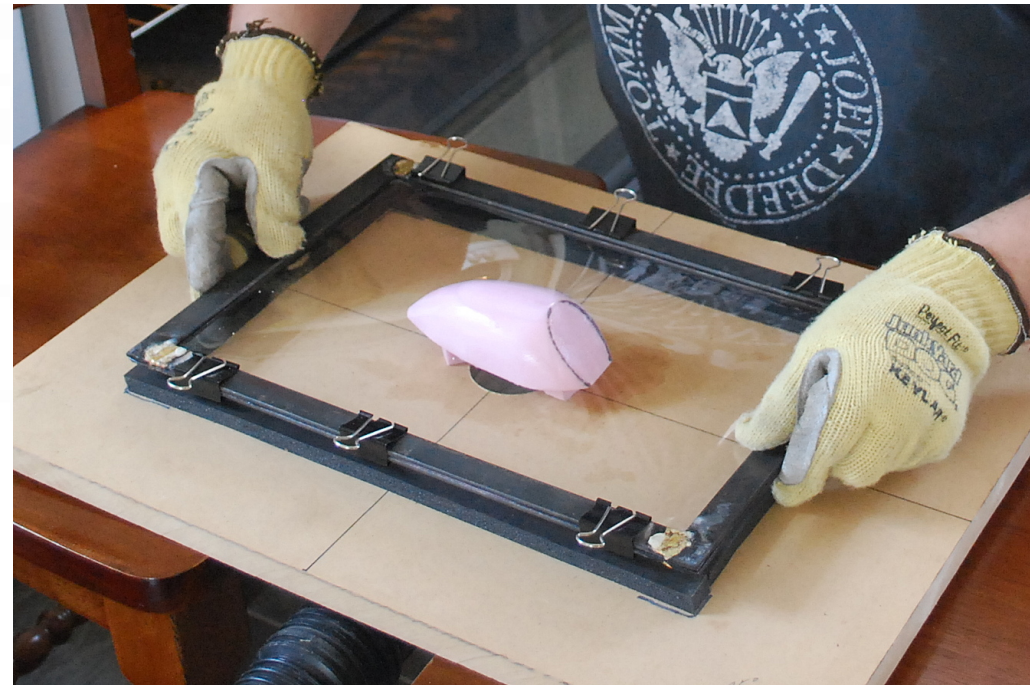
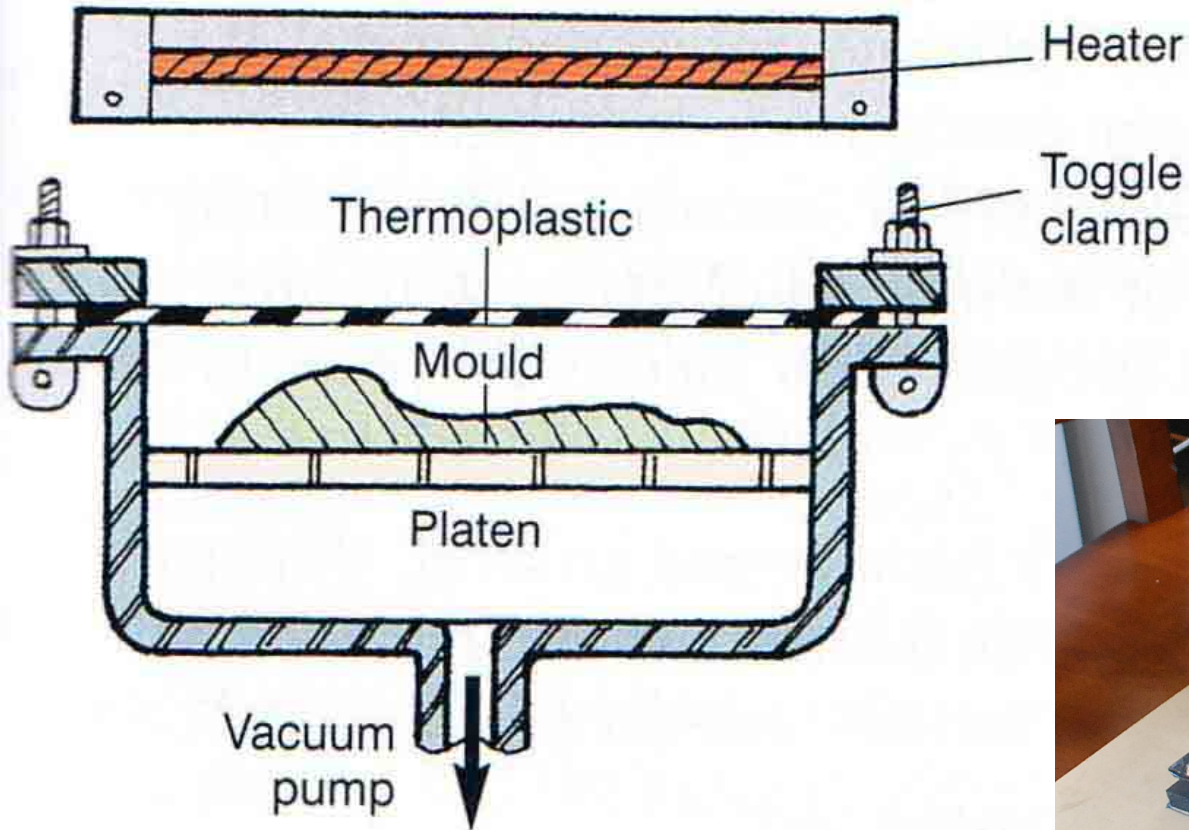

Making a canopy (windshield) for a model airplane.

Rapid Prototyping Fabrication Technologies

- Computer-controlled
- Requires little skill to operate the machinery
- Generally safe to use
- May have limitations as to materials or production capacity.
- But may also offer new capabilities not previously available.

Laser cutter / Water jet

- ✓ Fast
- ✓ Precise
- ✓ Cheap
- ✓ Wide choice of materials
- ✗ Parts are only 2D (but assemblies can be 3D)

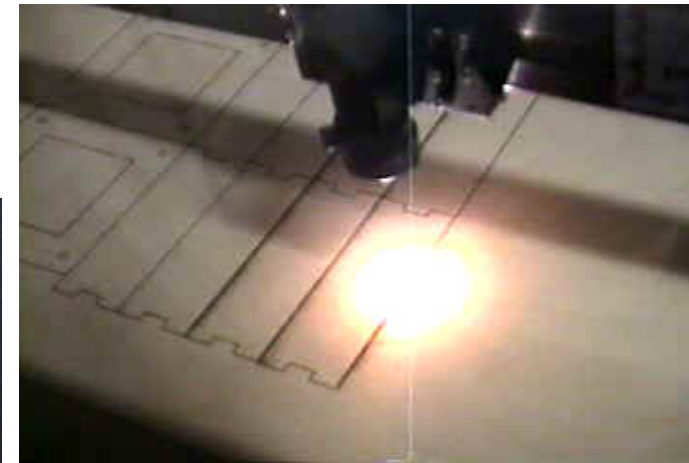

Cheap 3D Printing

- ✗ Slow
- ✗ Less precise
- ✗ More expensive
- ✗ Limited materials
- ✗ Support material may be required
- ✓ Complex 3D structures!

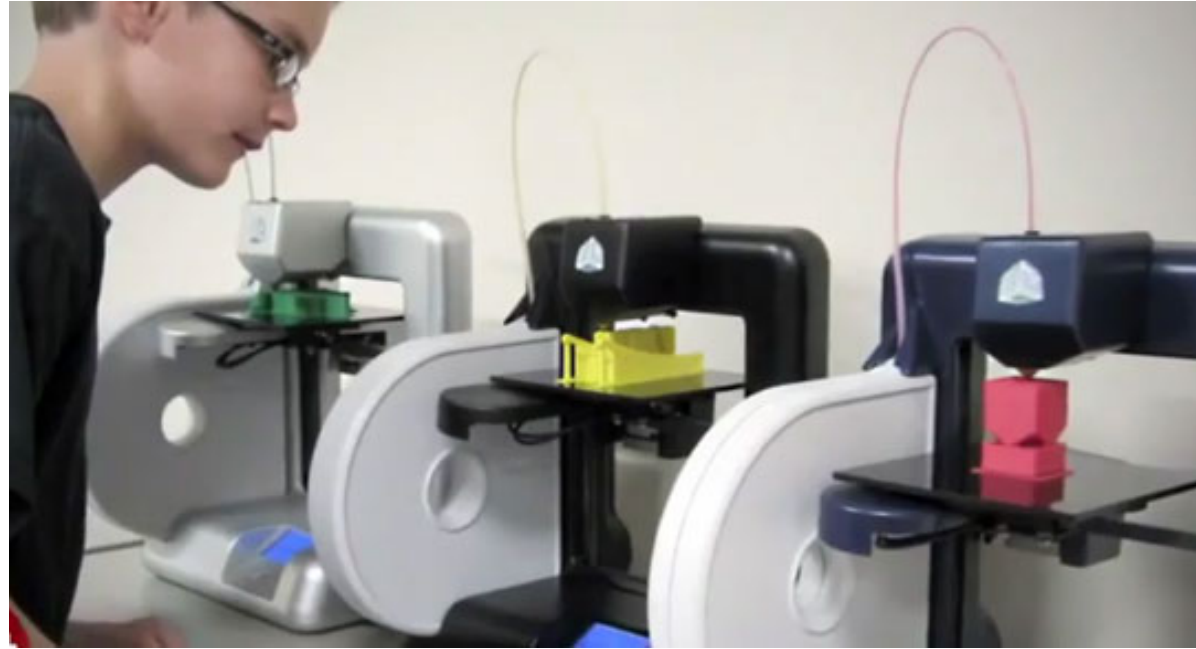

High End 3D Printing

- ✓ Precise
- ✓ Multicolor
- ✓ Complex materials
- ✗ Slow
- ✗ Expensive

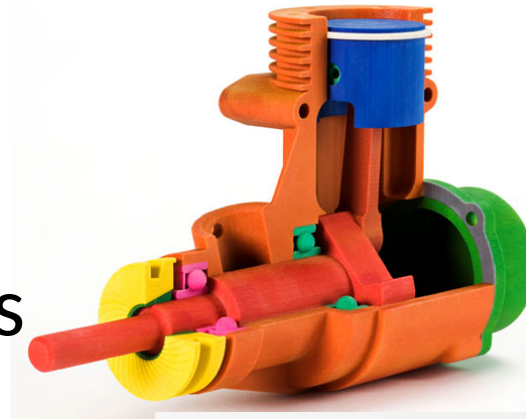

What Is Maker Culture?

- “Do it yourself” meets high technology and open source movements.
- The high tech part:
 - CAD software
 - Laser cutters, 3D printing, Arduinos, etc.
- Why is this good?
 - Rapid prototyping: hold your ideas in your hand!
 - Extreme customization / personalization
 - New modes of artistic expression

Maker Culture Around Us

- Hacker spaces / maker spaces
- Reprap and other open source 3D printers
- Thingiverse & similar sites: marketplaces for 3D models (many are free)



Additive Manufacturing

- Another term for 3D printing.
- Add material layer by layer, instead of cutting material away (as in machining).
- Many different technologies:
 - Fused deposition modeling (squirt molten plastic)
 - Binder jet printing (liquid binder solidifies powder)
 - Selective laser sintering (laser solidifies powder)
 - Stereolithography (laser solidifies liquid)
 - ... and more!

Lipson and Kurman (2013): Fabricated

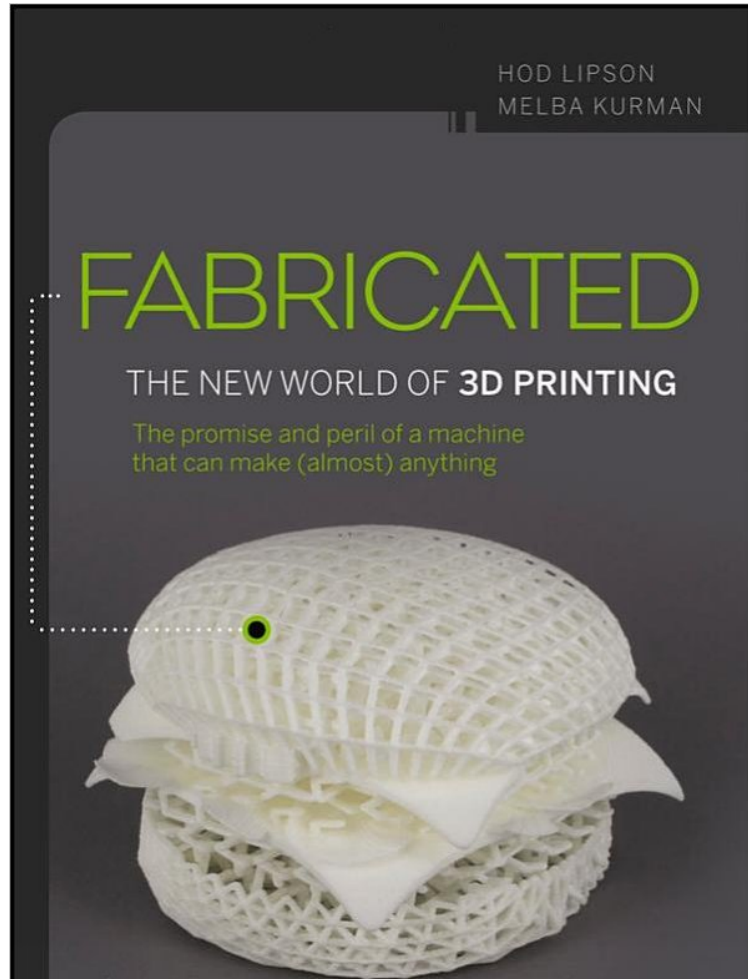

- Excellent overview of both the state of the art and the future of 3D printing.
- In chapter 2 they define 10 Principles of 3D Printing.

10 Principles of 3D Printing

Lipson and Kurman (2013)

1. Manufacturing complexity is free.
 - No extra cost for ornate shapes, extra holes, etc.
2. Variety is free.
 - No cost to make many versions of an item, since no need for new molds or tooling.
3. No assembly required (in some cases).
 - Can print interlocked parts or multiple materials at the same time, e.g., a door plus its hinges.

10 Principles of 3D Printing

Lipson and Kurman (2013)

4. Zero lead time.

- Can print on demand; no waiting for parts.

5. Unlimited design space.

- Not subject to the geometric constraints that limit lathes, milling machines, or molding.
- Example: aircraft parts.

3D Printed Aircraft Parts

- Lighter parts → lighter planes → fuel savings.
- Use less material → cheaper to fabricate.



10 Principles of 3D Printing

Lipson and Kurman (2013)

6. Zero skill manufacturing.

- Production under computer control eliminates the need for expert machine operators.

7. Compact, portable manufacturing.

- Printers are small and build space can be large.

10 Principles of 3D Printing

Lipson and Kurman (2013)

8. Less waste by-product (than milling).

9. Infinite shades of materials.

- Can blend materials to produce continuous variations in hardness, color, etc.

10. Precise physical replication.

- High resolution scanning into digital design files will allow exchange of exact 3D printed replicas.

Neri Oxman's Gemini Chair



Lining is made of 44 different materials (including color). Skin combines three materials.

Printed on an Objet500 Connex3 from Stratasys.

Social Impacts We'll Look At

- Cheap 3D printed prosthetics for people missing arms or hands.
- 3D printed surgical implants, e.g., jaw bones.
- 3D printed organs: ears and bladders now, kidneys some day.
- 3D printed food (chocolate, meat, candies).
- 3D printed buildings (concrete).
- 3D printed plastic guns: invisible to X-rays.
- Does replication bring “piracy” of designs?

Florida boy, 6, gets prosthetic arm built with 3-D printer

The family of Alex Pring, who was born without a right arm, had been struggling with how they could afford a prosthetic limb - which can cost as high as \$40,000. A group of students at the University of Central Florida took the call as a challenge and built Alex a prosthetic arm that costs just \$350 with a 3-D printer.

BY JOE KEMP / NEW YORK DAILY NEWS / Monday, July 28, 2014, 10:19 AM



DOCTORS USED A 3D PRINTER TO PRINT AN ULTRASOUND FOR A BLIND EXPECTANT MOTHER



The Liberator: 3D Printed Gun

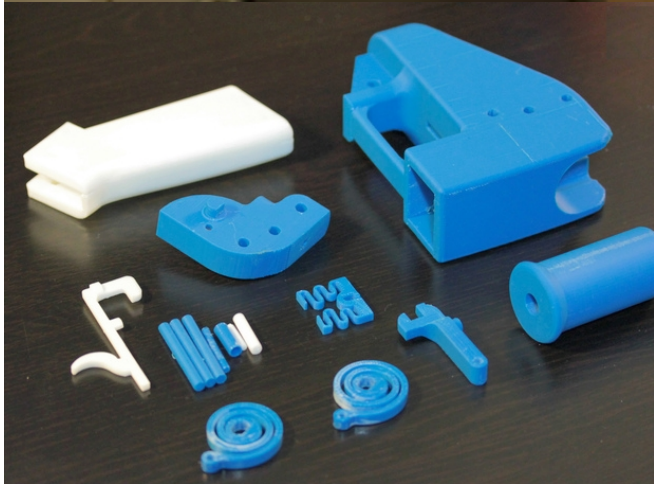

Cody Wilson of Defense Distributed

CAD Tools

- The big two:
 - AutoCad from AutoDesk
 - SolidWorks from Dassault Systemes
- Alibre/Invent
- Sketchup
- Blender
- CorelDraw, Inkscape, Rhino
- Sketch It Make It (developed at CMU)
- Many more...

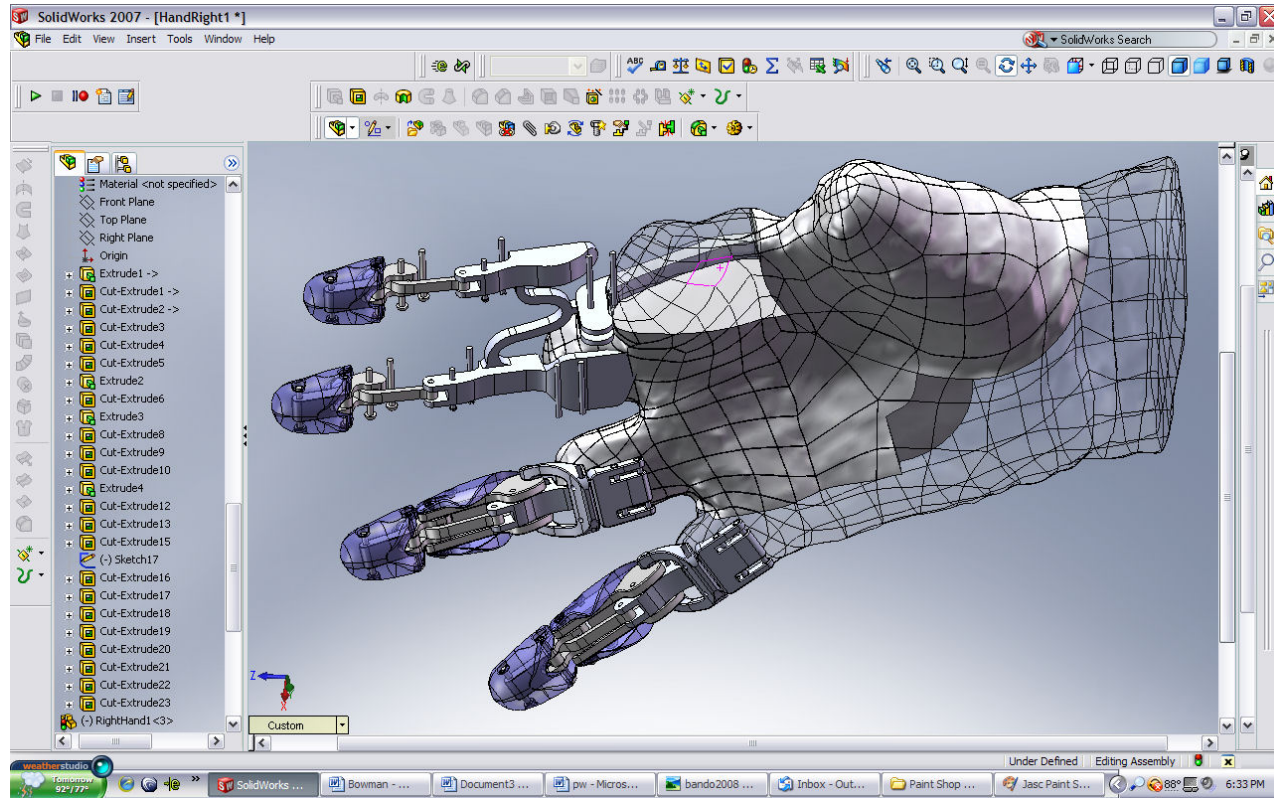

A Quick Look at SolidWorks

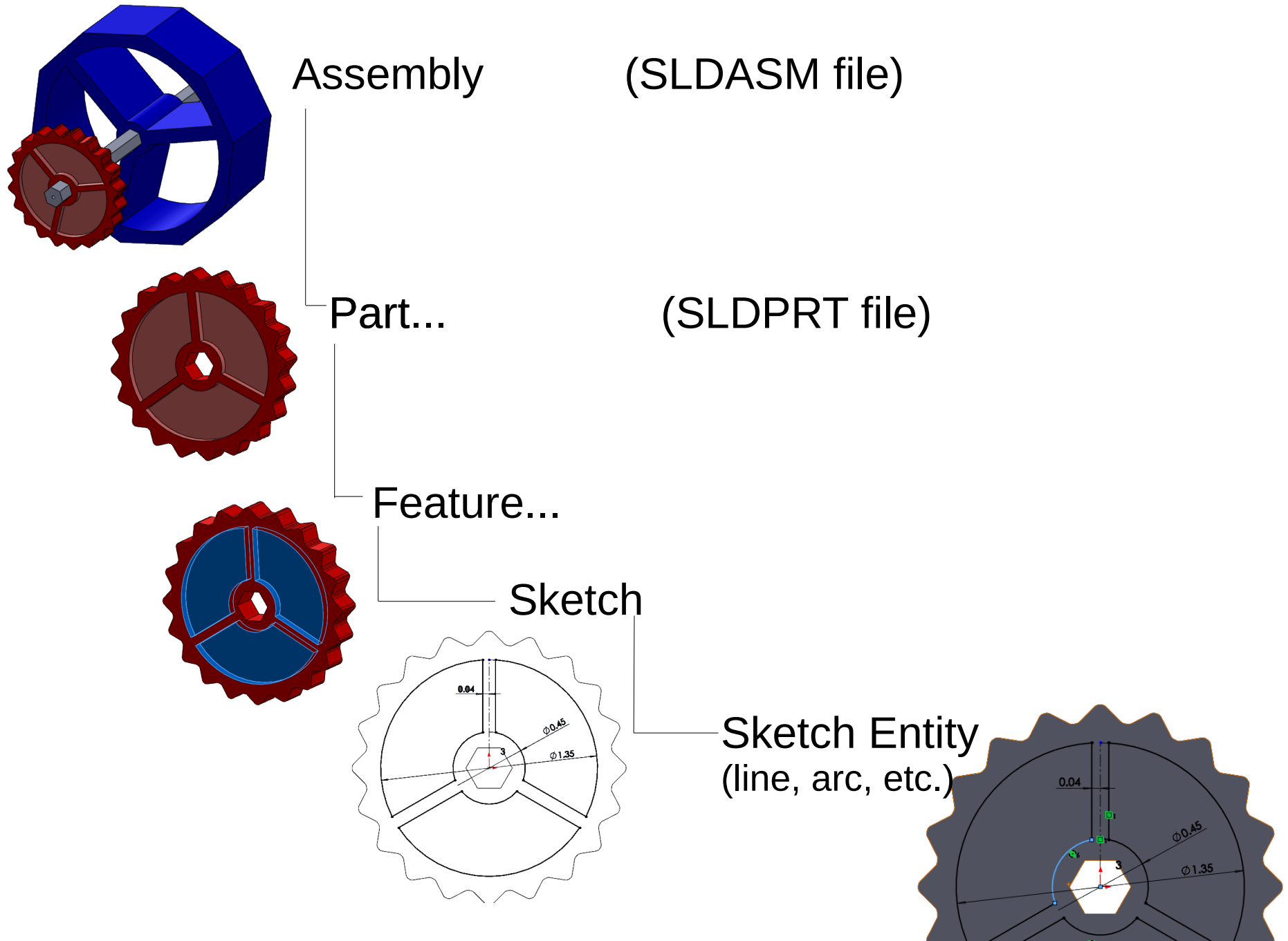

A Little More Detail

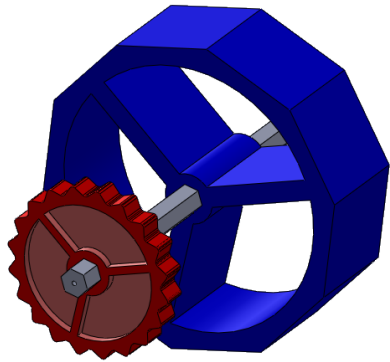

Assembly (SLDASM file)

- Mates
- Reference Geometry
- Subassembly...

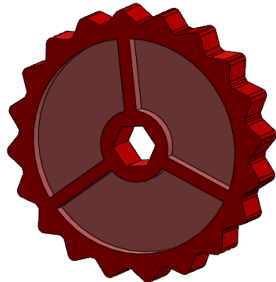

Part... (SLDPRT file)

— Reference Geometry

— Feature...

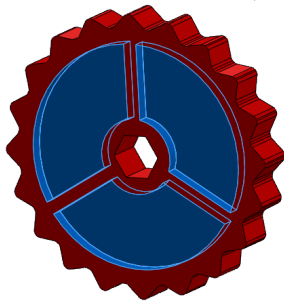

Sketch

— Entities

— Dimensions

— Relations

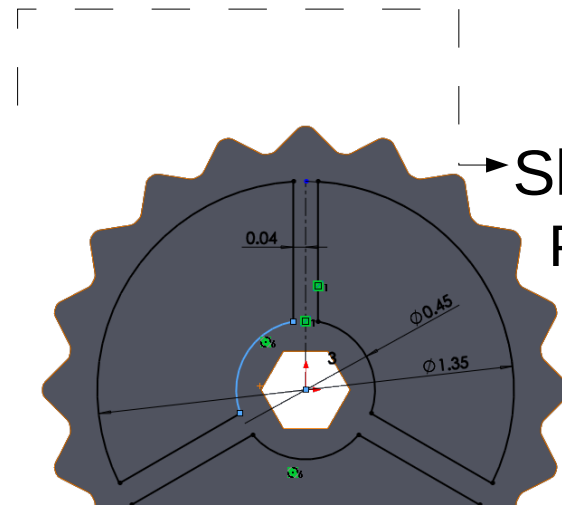
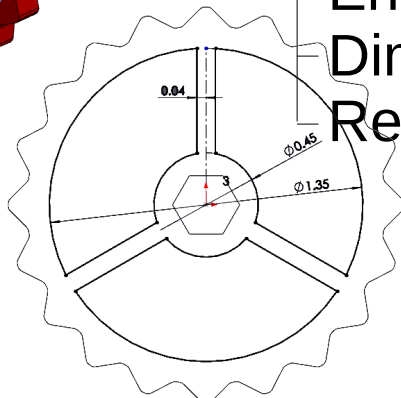

→ Sketch Entity Parameters...

How To Learn SolidWorks

0. **Buy a three-button mouse with scroll wheel.**
1. We'll teach you SolidWorks, starting next class. The scripts are linked from the class schedule.
2. SolidWorks has good built-in tutorials; click on the little “house” icon (SolidWorks Resources) on the right side of the screen, then click on “Welcome to SolidWorks” and select the “Learn” tab at the top.
3. Lynda.com (LinkedIn Learning) offers excellent quality video tutorials; see the link from our course home page.
4. Thousands of random YouTube videos, including specialized topics such as how to make involute gears.