

Lecture 11:

Directory-Based Cache Coherence

**Parallel Computer Architecture and Programming
CMU 15-418/15-618, Fall 2024**

Today: what you should know

What limits the scalability of snooping-based approaches to cache coherence?

How does a directory-based scheme avoid these problems?

How can the storage overhead of the directory structure be reduced? (and at what cost?)

Implementing cache coherence

The snooping cache coherence protocols from the last lecture relied on broadcasting coherence information to all processors over the chip interconnect.

Every time a cache miss occurred, the triggering cache communicated with all other caches!

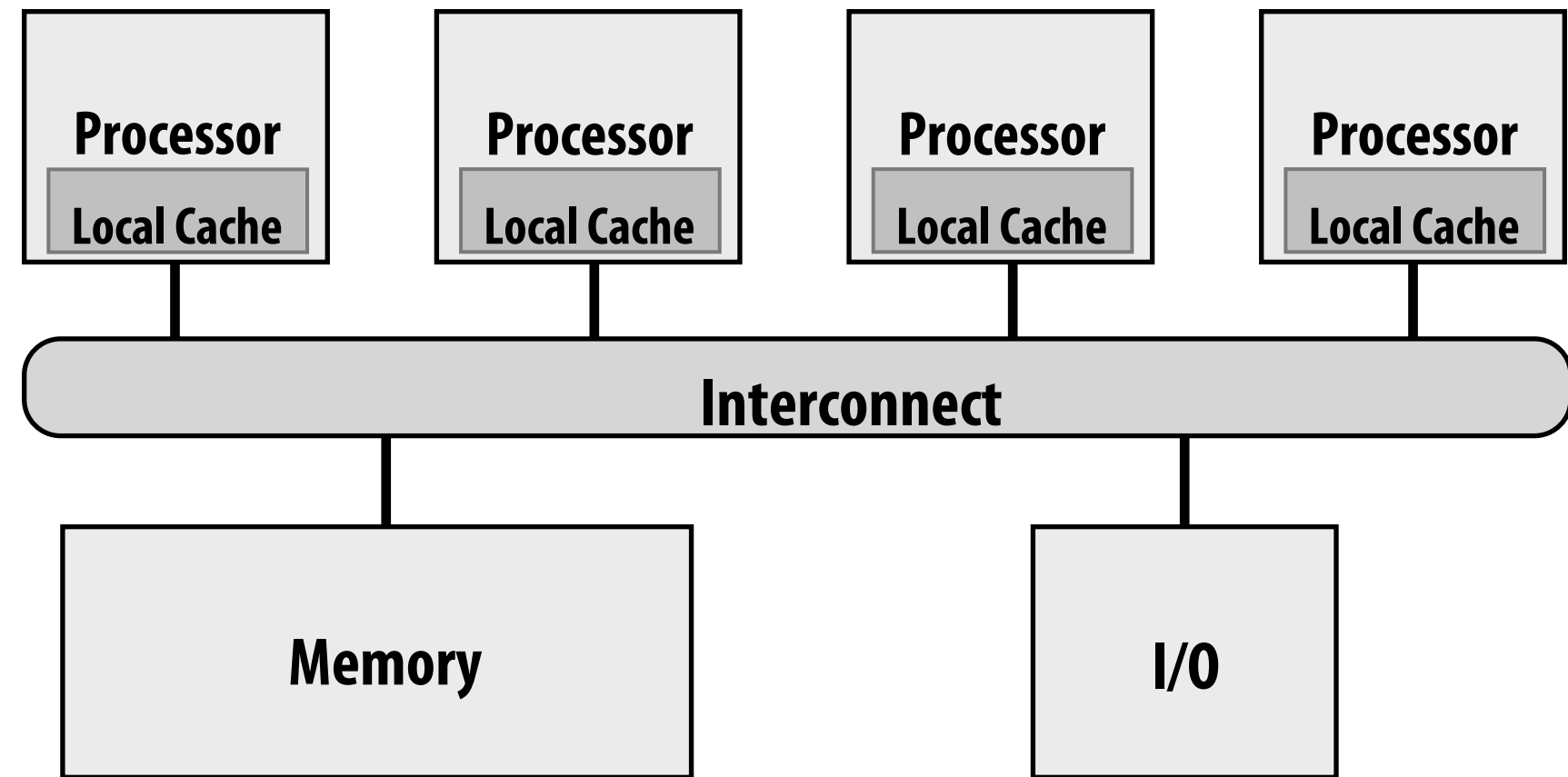

We discussed what information was communicated and what actions were taken to implement the coherence protocol.

We did not discuss how to implement broadcasts on an interconnect.
(one example is to use a shared bus for the interconnect)

Problem: scaling cache coherence to large machines

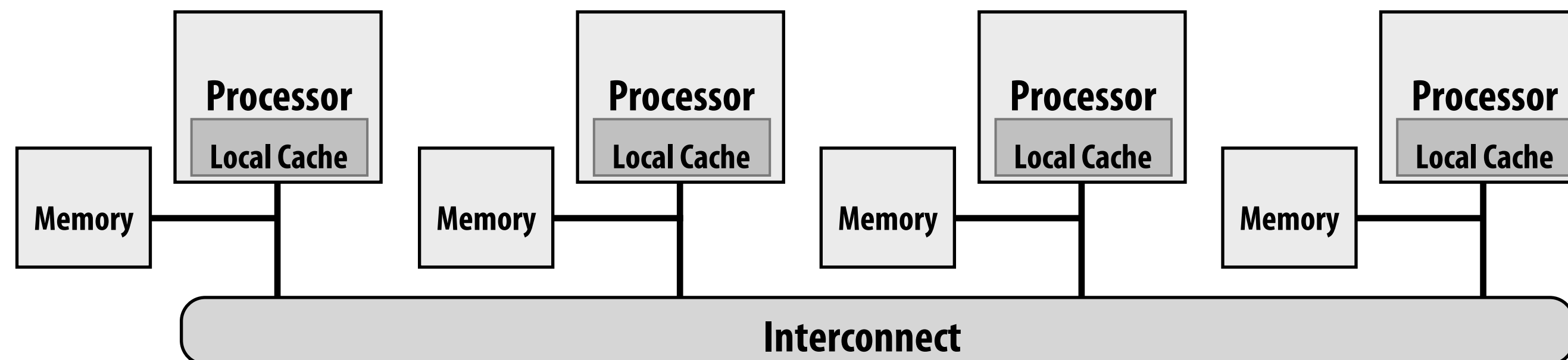

Recall non-uniform memory access (NUMA) shared memory systems (e.g., PSC Blacklight)

Idea: locating regions of memory near the processors increases scalability: it yields higher aggregate bandwidth and reduced latency (especially when there is locality in the application)

But... efficiency of NUMA system does little good if the coherence protocol can't also be scaled!

Consider this case: processor accesses nearby memory (good...), but to ensure coherence still must broadcast to all other processors it is doing so (bad...)

Some terminology:

cc-NUMA = "cache-coherent, non-uniform memory access"

Distributed shared memory system (DSM): cache coherent, shared address space, but architecture implemented by physically distributed memories

One possible solution: hierarchical snooping

Use snooping coherence at each level

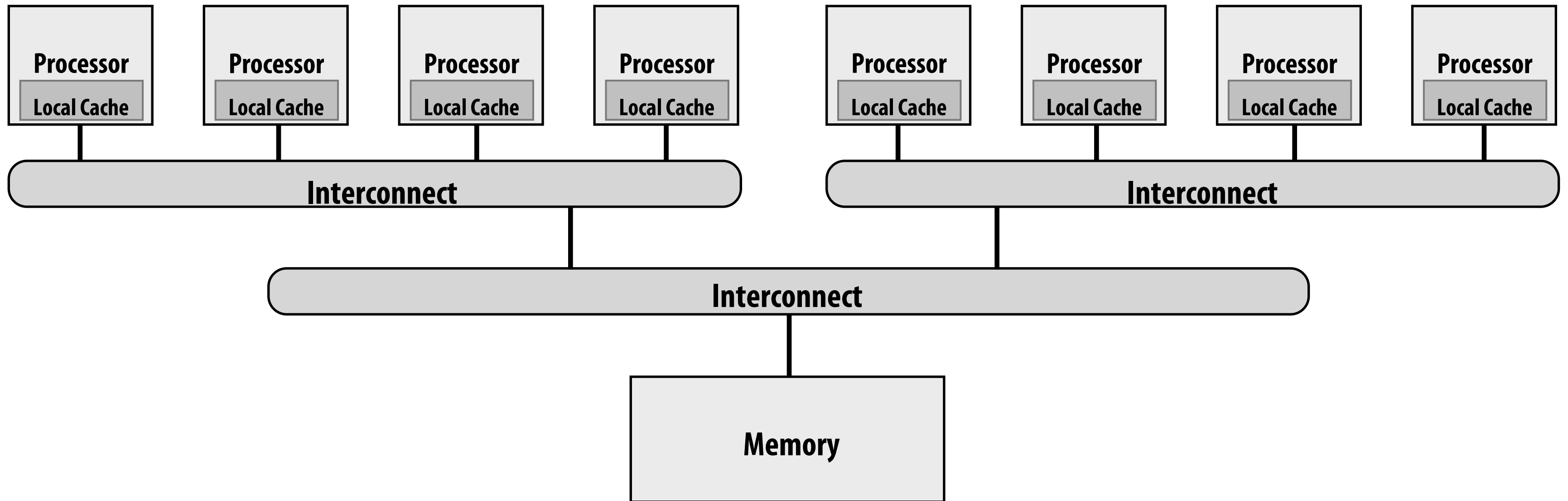

Another example: with memory localized with the groups of processors, rather than centralized

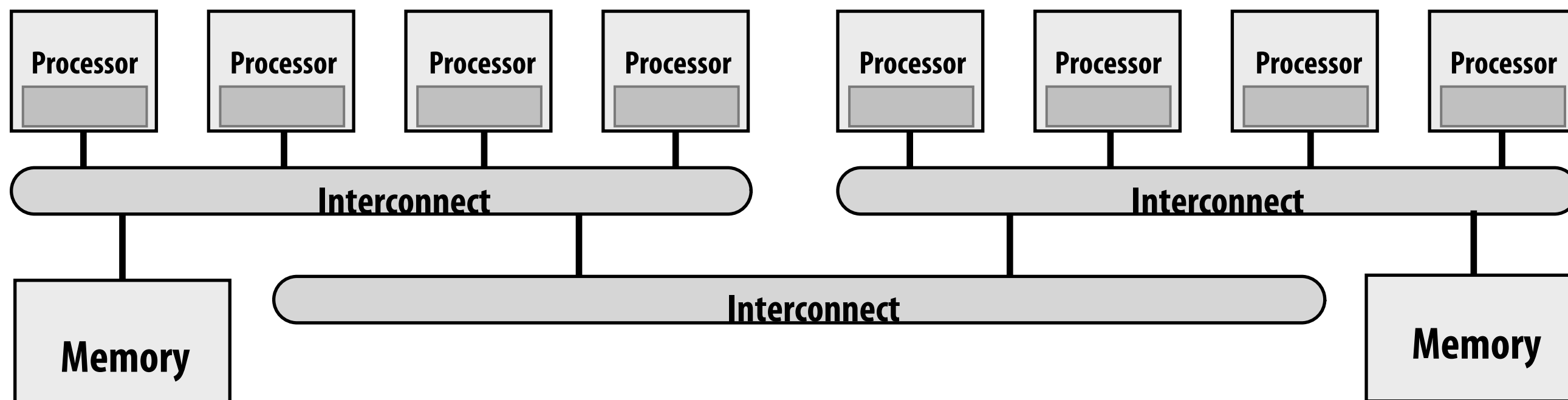

One possible solution: hierarchical snooping

Use snooping coherence at each level

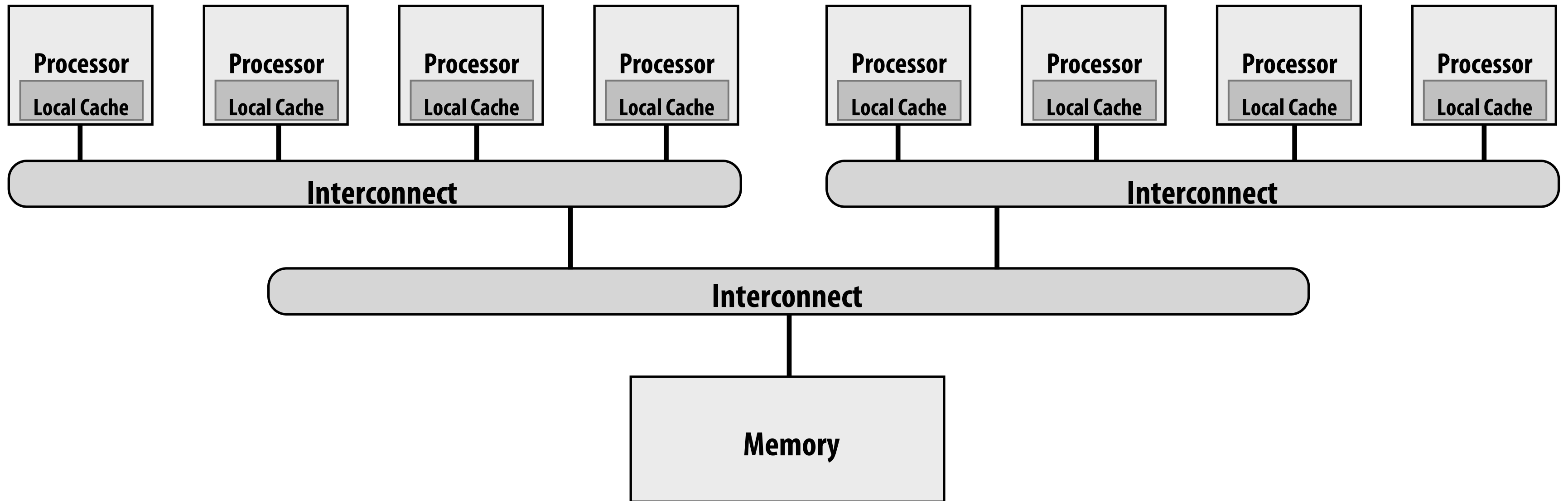

Advantages

- **Relatively simple to build (already must deal with similar issues due to multi-level caches)**

Disadvantages

The root of the network can become a bottleneck

Larger latencies than direct communication

Does not apply to more general network topologies (meshes, cubes)

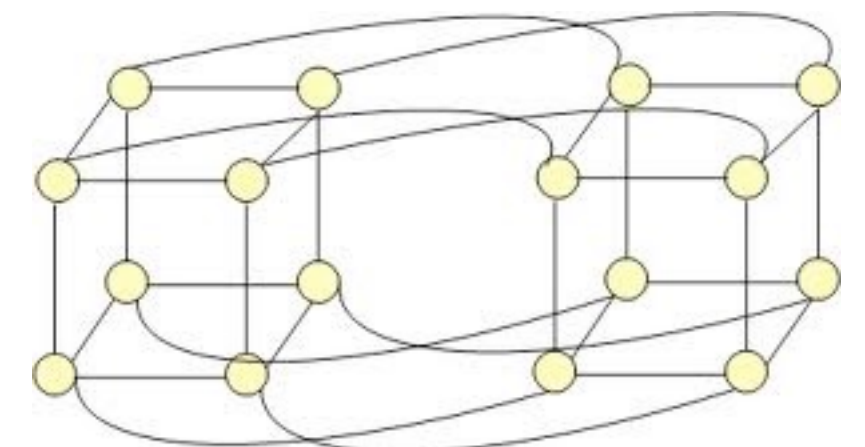

Scalable cache coherence using directories

Snooping schemes broadcast coherence messages to determine the state of a line in the other caches

Alternative idea: avoid broadcast by storing information about the status of the line in one place: a “directory”

- **The directory entry for a cache line contains information about the state of the cache line in all caches.**
- **Caches look up information from the directory as necessary**
- **Cache coherence is maintained by point-to-point messages between the caches on a “need to know” basis (not by broadcast mechanisms)**

A very simple directory

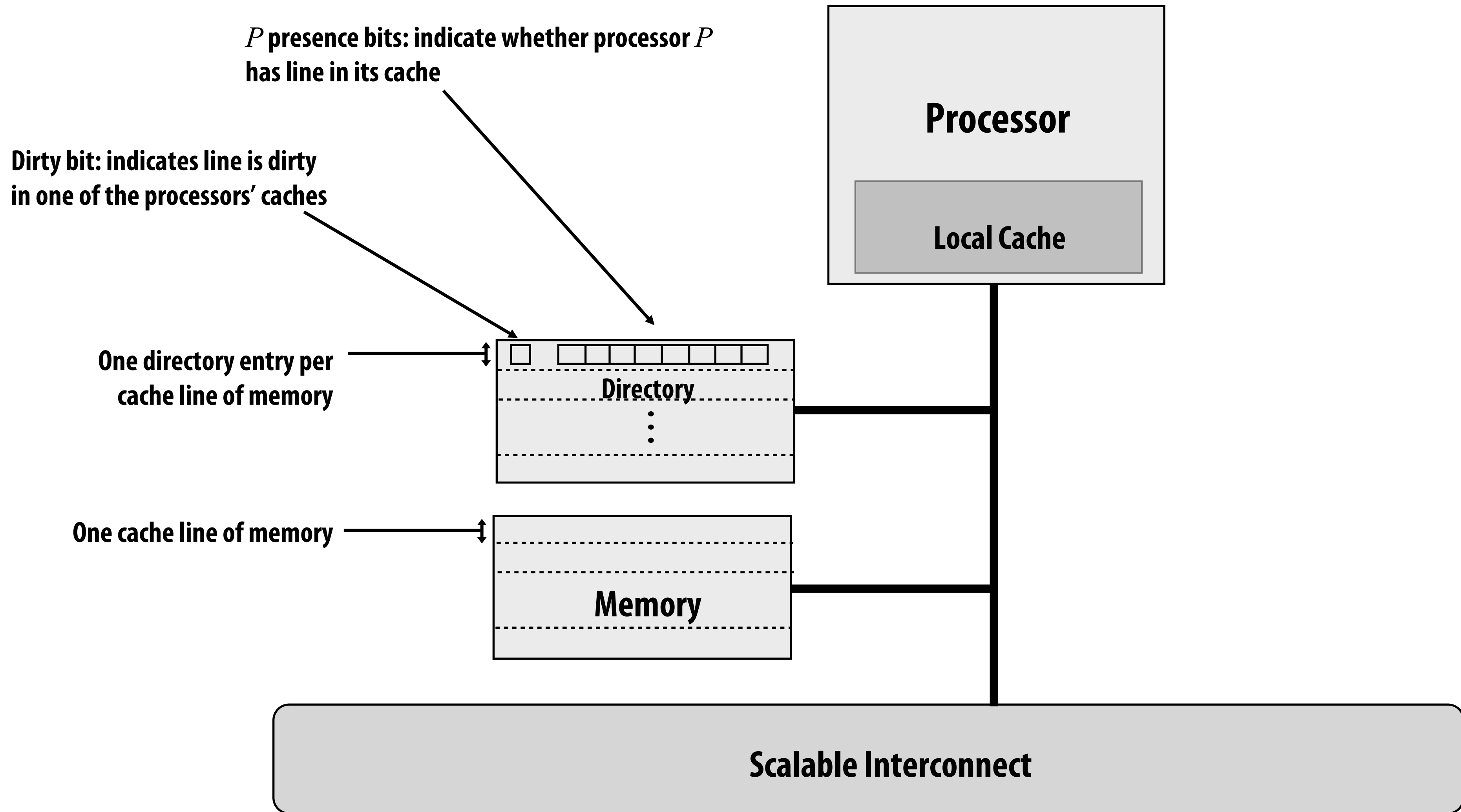

A distributed directory

Example: directory partition is co-located with memory it describes

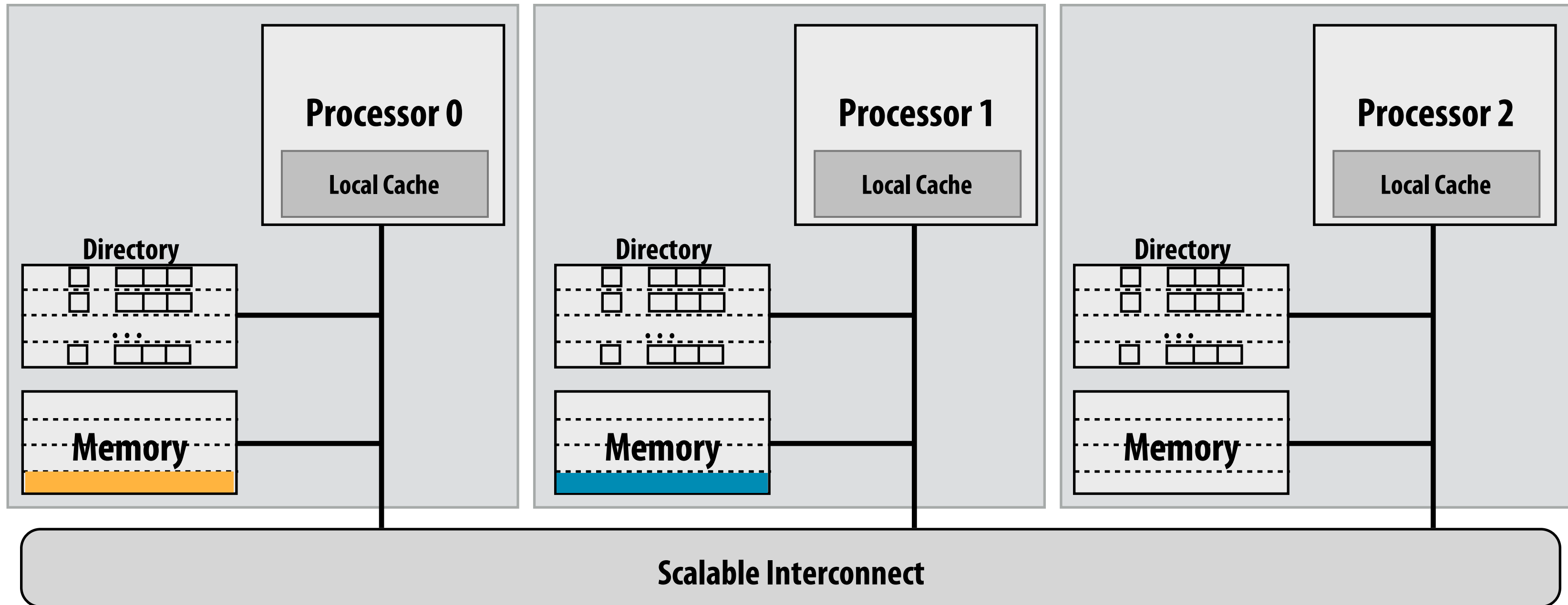

“Home node” of a line: node with memory holding the corresponding data for the line

Example: node 0 is the home node of the yellow line, node 1 is the home node of the blue line

“Requesting node”: node containing processor requesting line

Example 1: read miss to clean line

Read from main memory by processor 0 of the blue line: line is not dirty

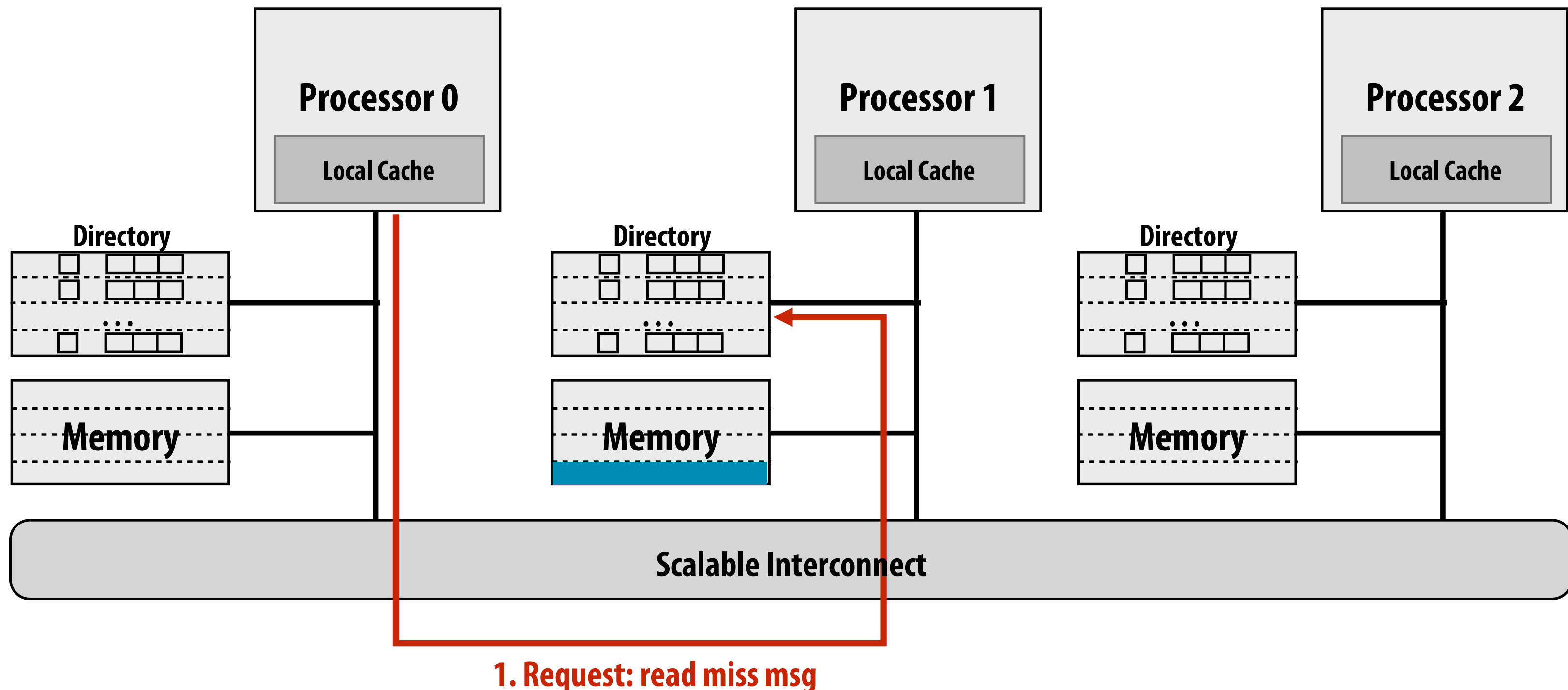

Read miss message sent to home node of the requested line

Home directory checks entry for line

Example 1: read miss to clean line

Read from main memory by processor 0 of the blue line: line is not dirty

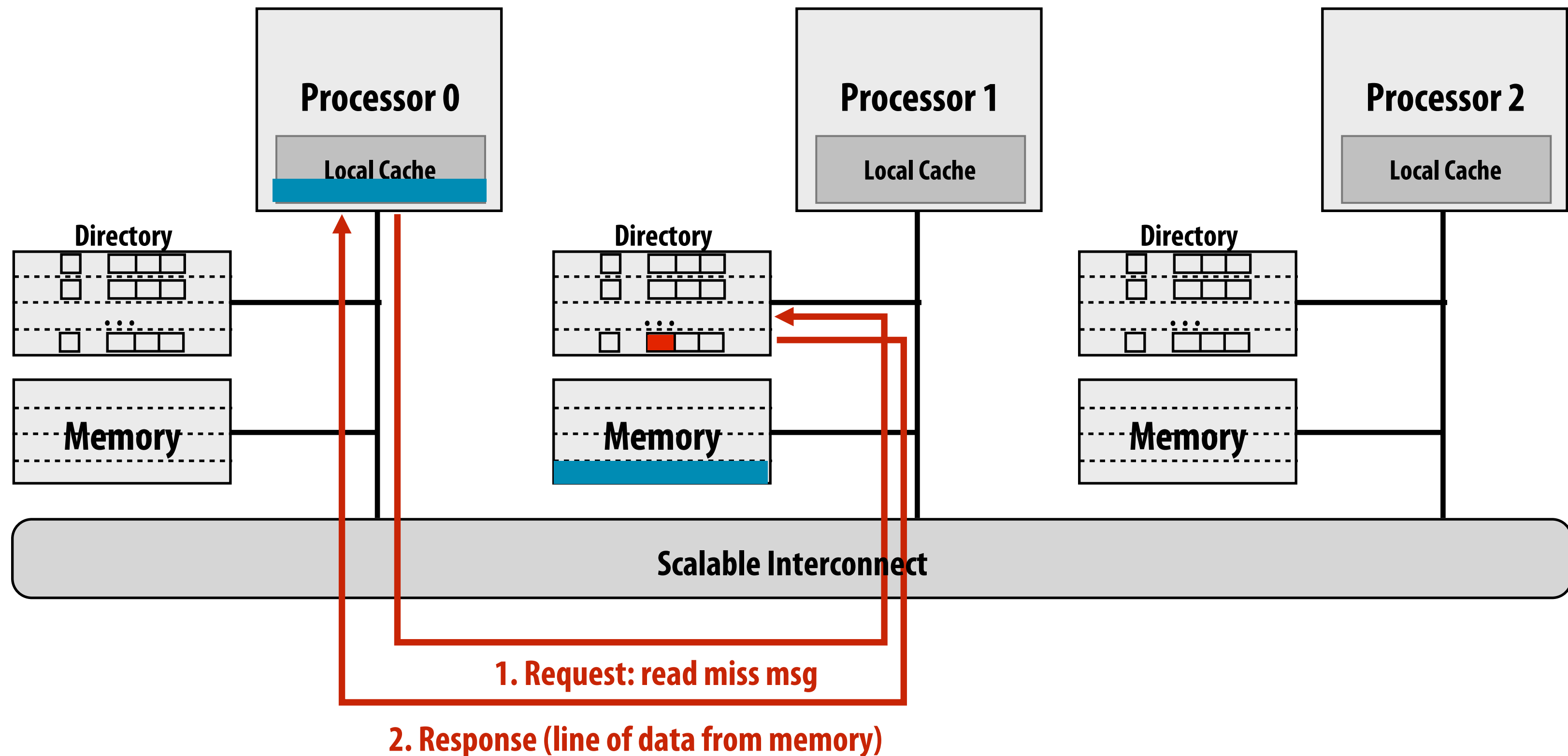

Read miss message sent to home node of the requested line

Home directory checks entry for line

- **If dirty bit for cache line is OFF, respond with contents from memory, set presence[0] to true (to indicate line is cached by processor 0)**

Example 2: read miss to dirty line

Read from main memory by processor 0 of the blue line: line is dirty (contents in P2's cache)

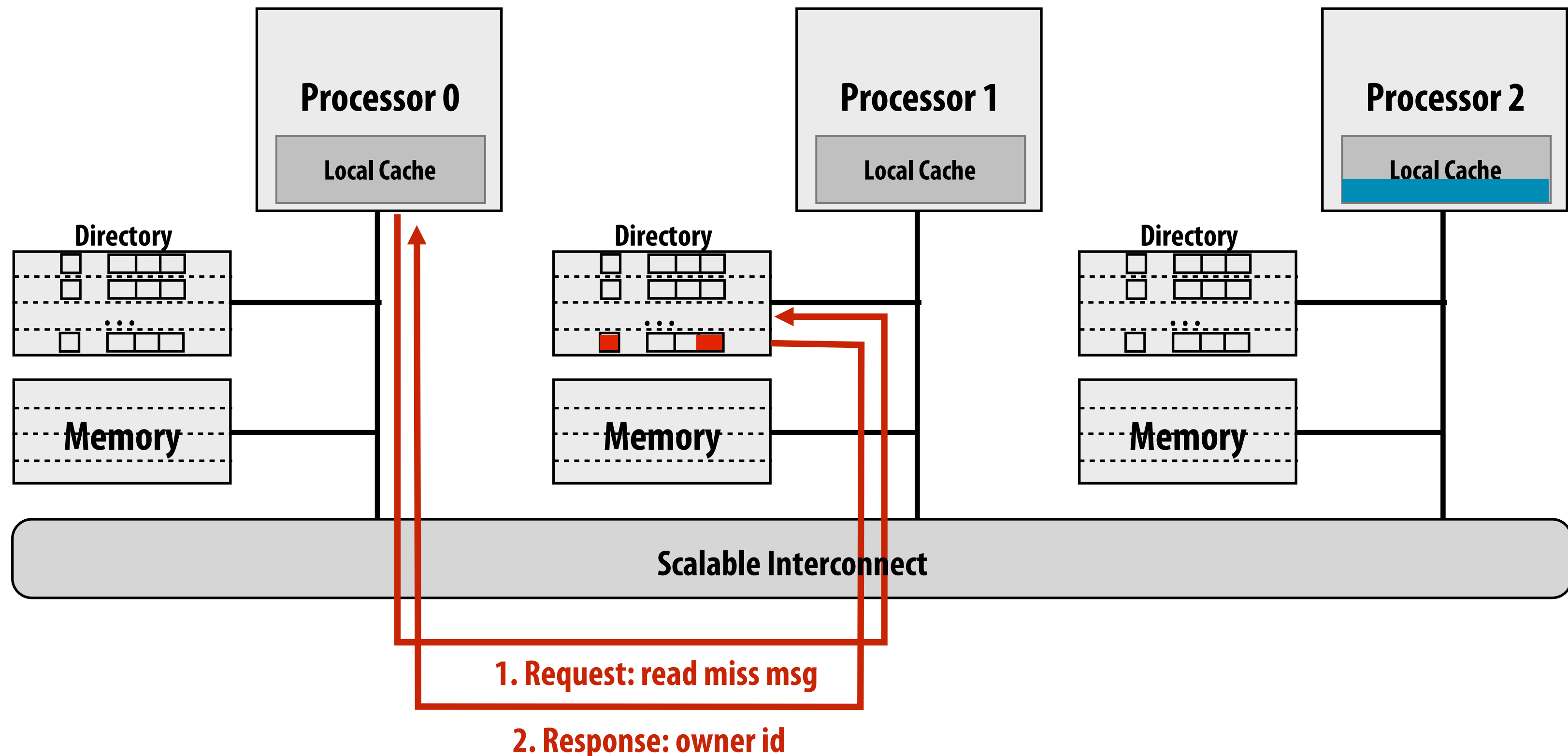

If dirty bit is ON, then data must be sourced by another processor (with the most up-to-date copy of the line)

Home node must tell requesting node where to find data

- Responds with message providing identity of line owner (“get it from P2”)

Example 2: read miss to dirty line

Read from main memory by processor 0 of the blue line: line is dirty (contents in P2's cache)

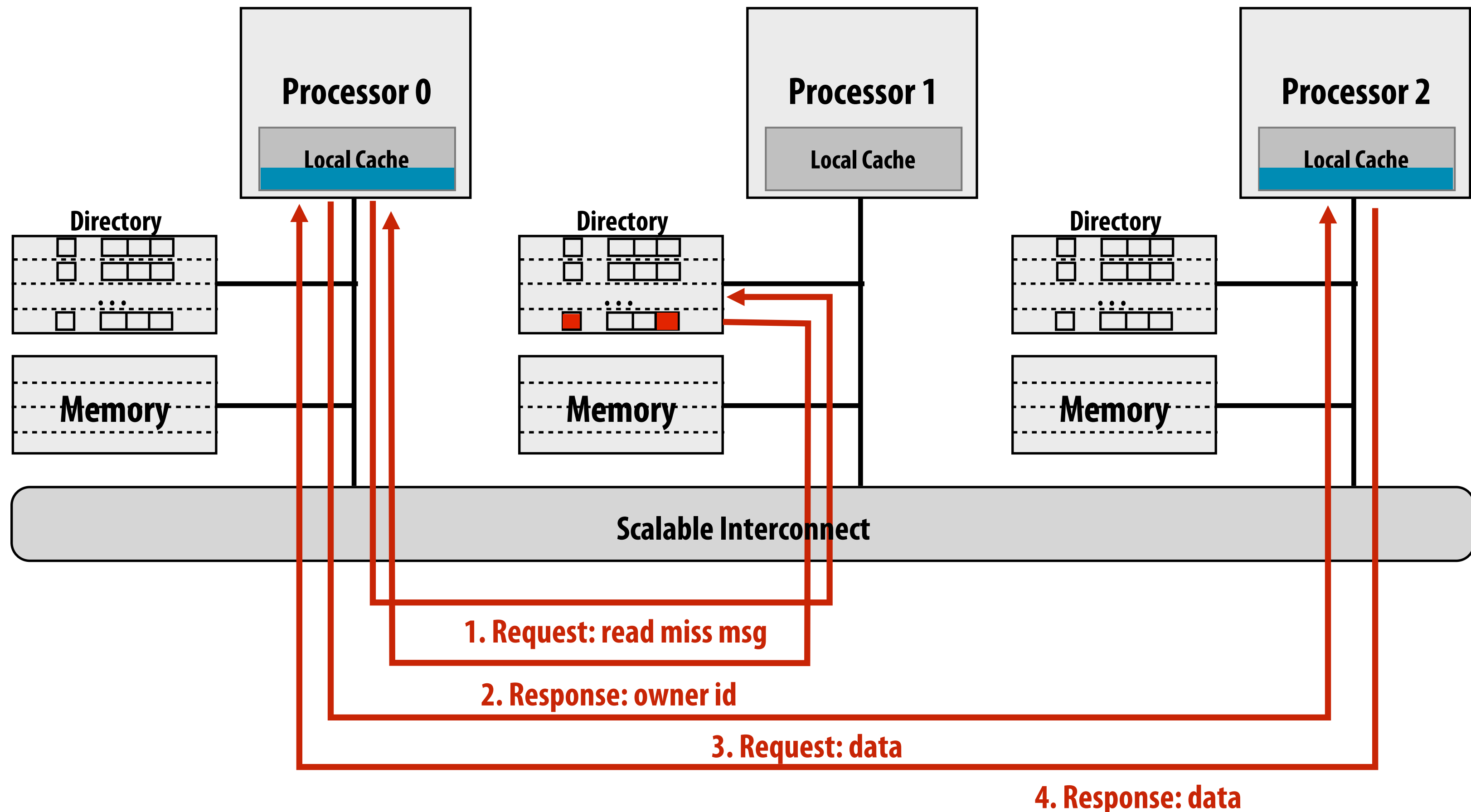

1. If dirty bit is ON, then data must be sourced by another processor
2. Home node responds with message providing identity of line owner
3. Requesting node requests data from owner
4. Owner changes state in cache to SHARED (read only), responds to requesting node

Example 2: read miss to dirty line

Read from main memory by processor 0 of the blue line: line is dirty (contents in P2's cache)

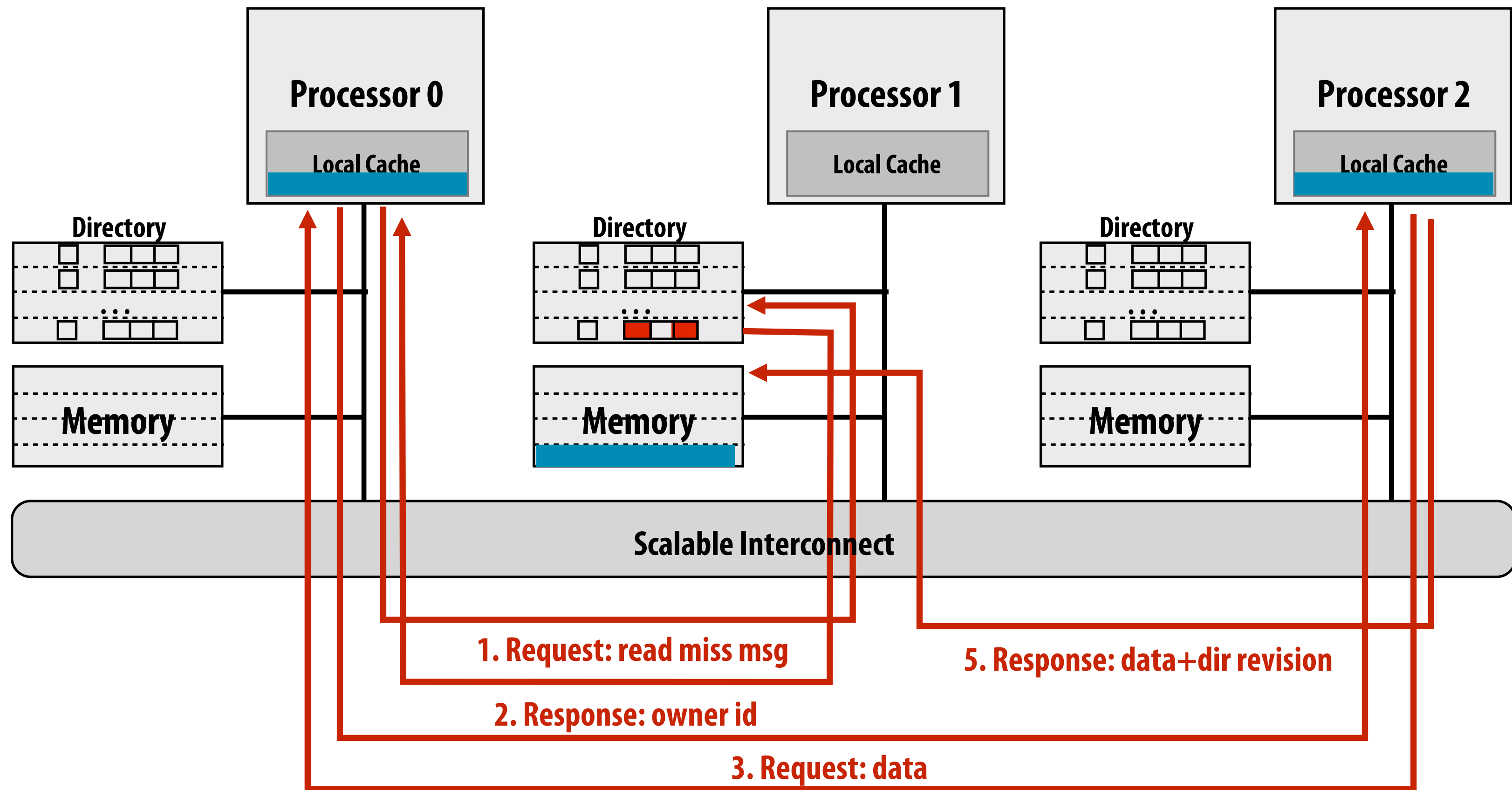

1. If dirty bit is ON, then data must be sourced by another processor
2. Home node responds with message providing identity of line owner
3. Requesting node requests data from owner
4. Owner responds to requesting node, changes state in cache to SHARED (read only)
5. Owner also responds to home node, home clears dirty, updates presence bits, updates memory

Example 3: write miss

Write to memory by processor 0: line is clean, but resident in P1's and P2's caches

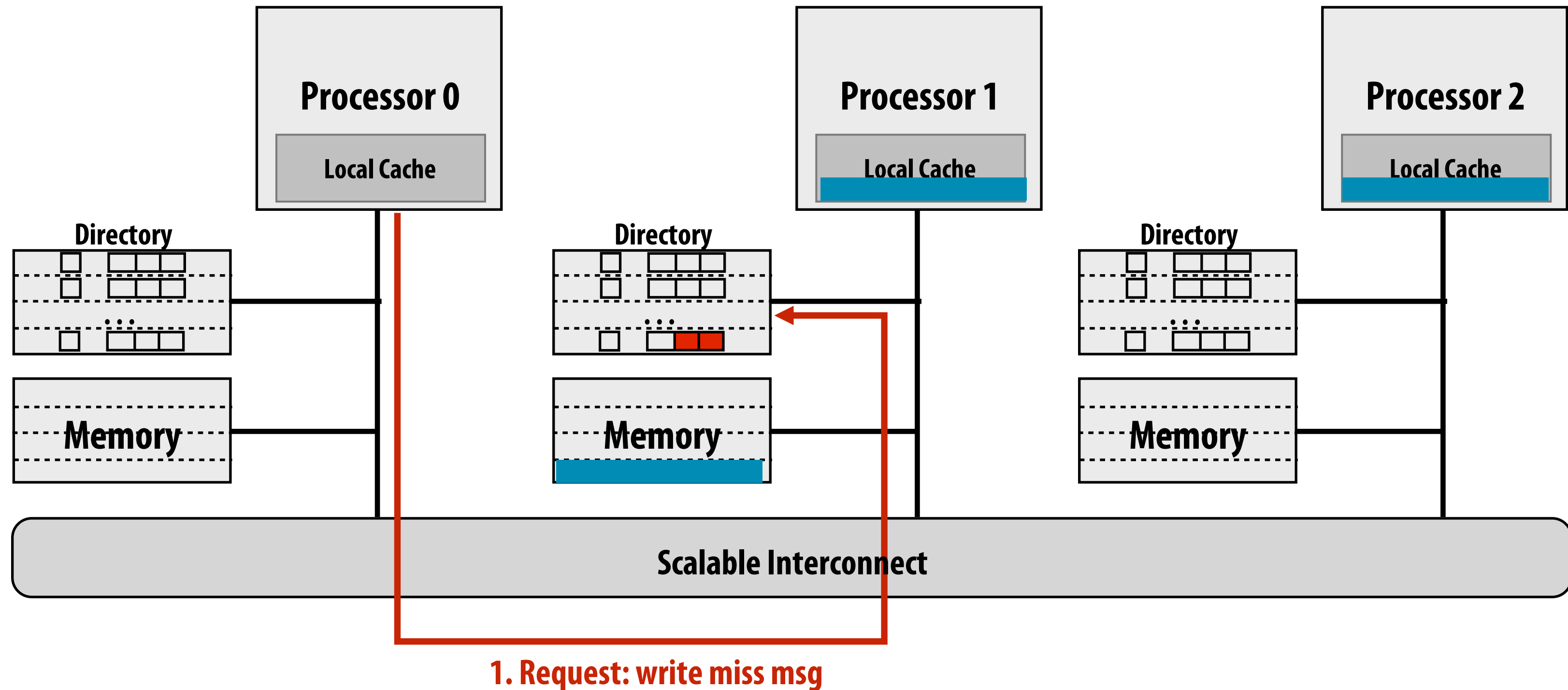

Example 3: write miss

Write to memory by processor 0: line is clean, but resident in P1's and P2's caches

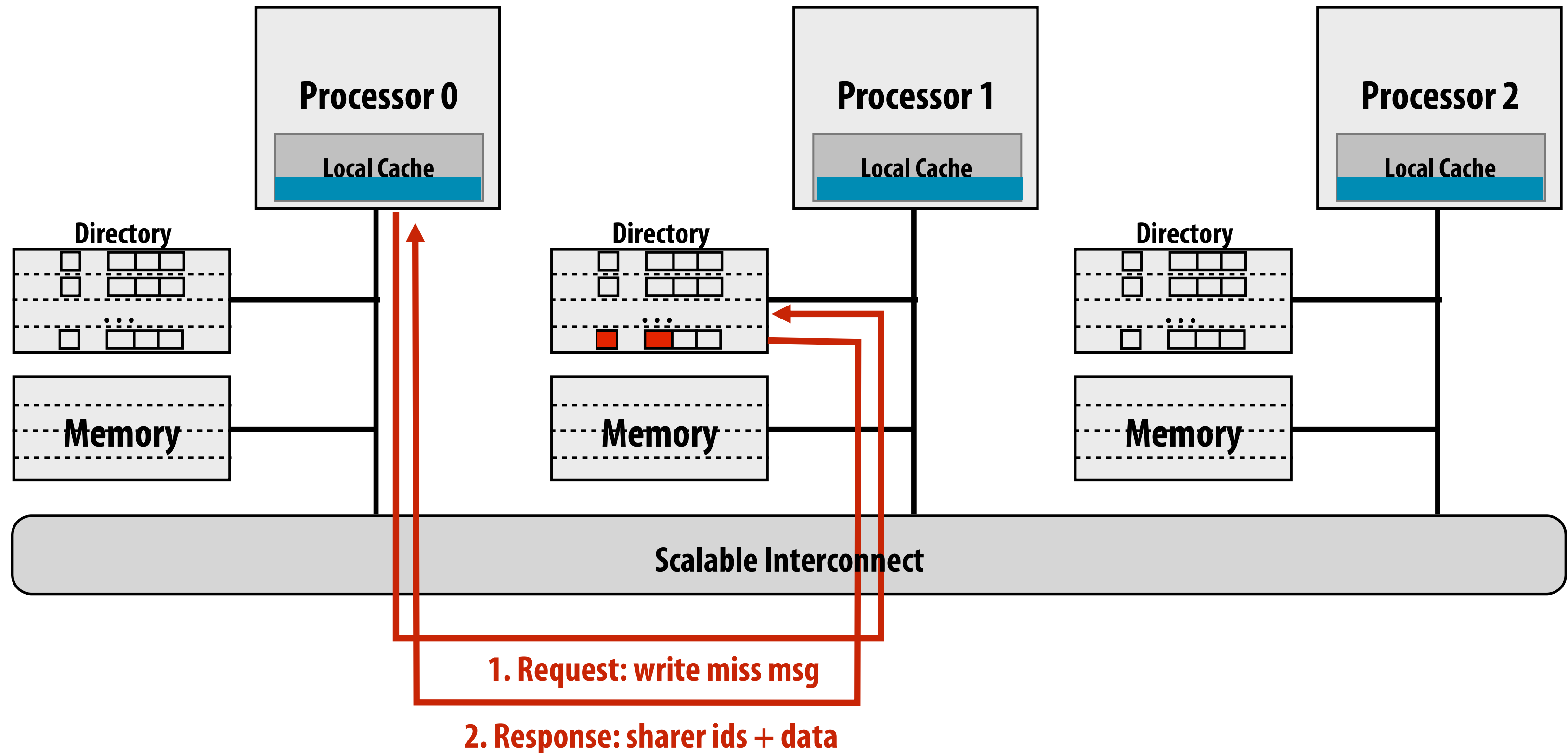

Example 3: write miss

Write to memory by processor 0: line is clean, but resident in P1's and P2's caches

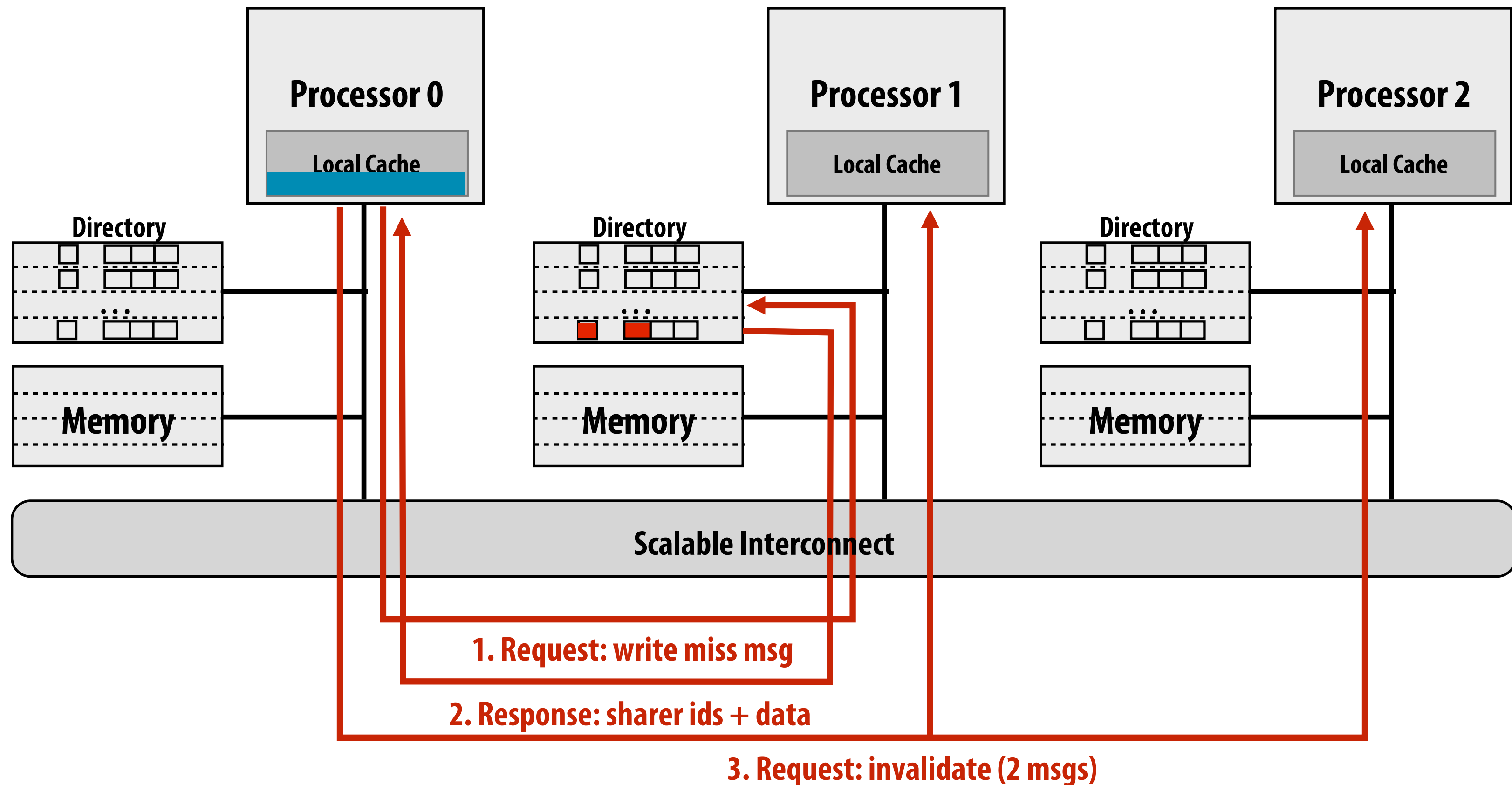

Example 3: write miss

Write to memory by processor 0: line is clean, but resident in P1's and P2's caches

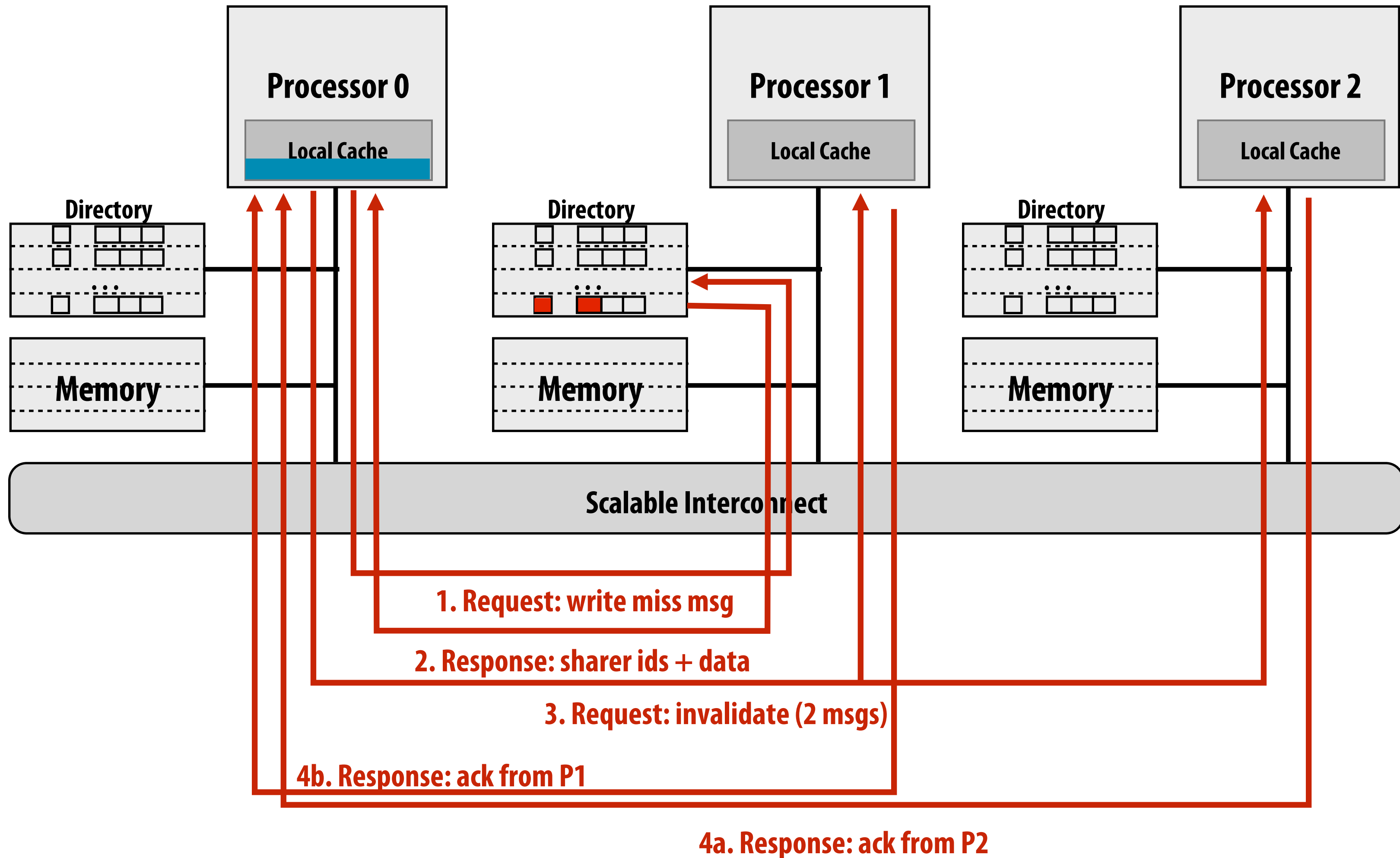

After receiving both invalidation acks, P0 can perform write

Advantage of directories

On reads, directory tells requesting node exactly where to get the line from

- **Either from home node (if the line is clean)**
- **Or from the owning node (if the line is dirty)**
- **Either way, retrieving data involves only point-to-point communication**

On writes, the advantage of directories depends on the number of sharers

- **In the limit, if all caches are sharing data, all caches must be communicated with (just like broadcast in a snooping protocol)**

Cache invalidation patterns

64 processor system

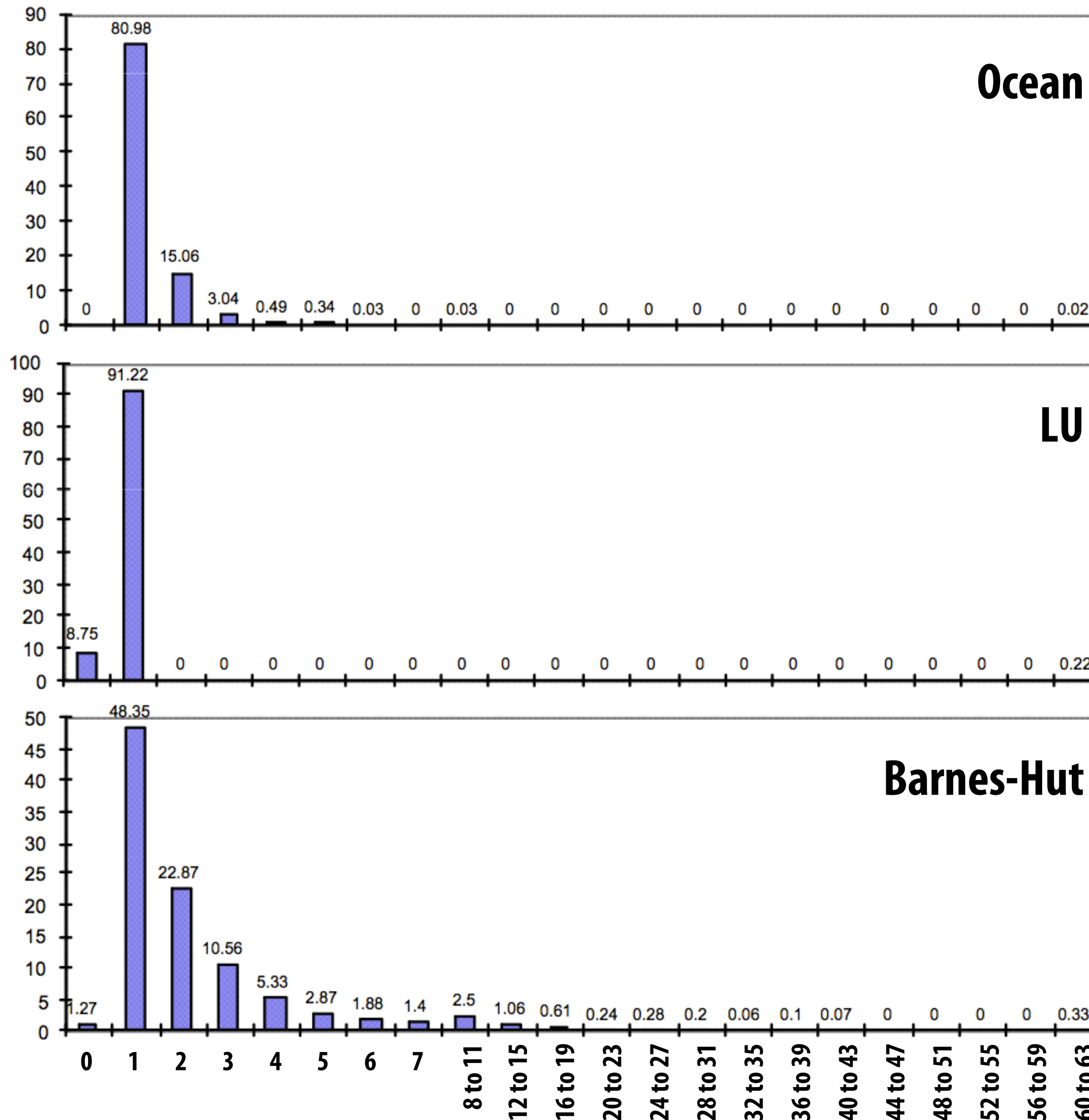

Graphs plot histogram of number of sharers of a line at the time of a write

In general only a few processors share the line (only a few processors must be told of writes)

Not shown here, but the expected number of sharers typically increases slowly with P (good!)

In general, only a few sharers during a write

Access patterns

- **“Mostly-read” objects: lots of sharers but writes are infrequent, so minimal impact on performance (e.g., root node in Barnes-Hut)**
- **Migratory objects (one processor reads/writes for while, then another, etc.): very few sharers, count does not scale with number of processors**
- **Frequently read/written objects: frequent invalidations, but sharer count is low because count cannot build up in short time between invalidations (e.g, shared task queue)**
- **Low-contention locks: infrequent invalidations, no performance problem**
- **High-contention locks: can be a challenge, because many readers present when lock released**

Implication 1: directories are useful for limiting coherence traffic

- **Don't need a broadcast mechanism to “tell everyone”**

Implication 2: suggests ways to optimize directory implementations (reduce storage overhead)

Lecture Checkpoint 1

Why does snooping-based coherence implementations have scalability problems?

What information does a directory track, and on what granularity?

What are the steps to service a read or a write miss with a directory?

Full bit vector directory representation

Recall: one presence bit per node

Storage proportional to $P \times M$

- P = number of nodes (e.g., processors)
- M = number of lines in memory

Storage overhead rises with P

- Assume 64 byte cache line size (512 bits)
- 64 nodes ($P=64$) \rightarrow 12% overhead
- 256 nodes ($P=256$) \rightarrow 50% overhead
- 1024 nodes ($P=1024$) \rightarrow 200% overhead

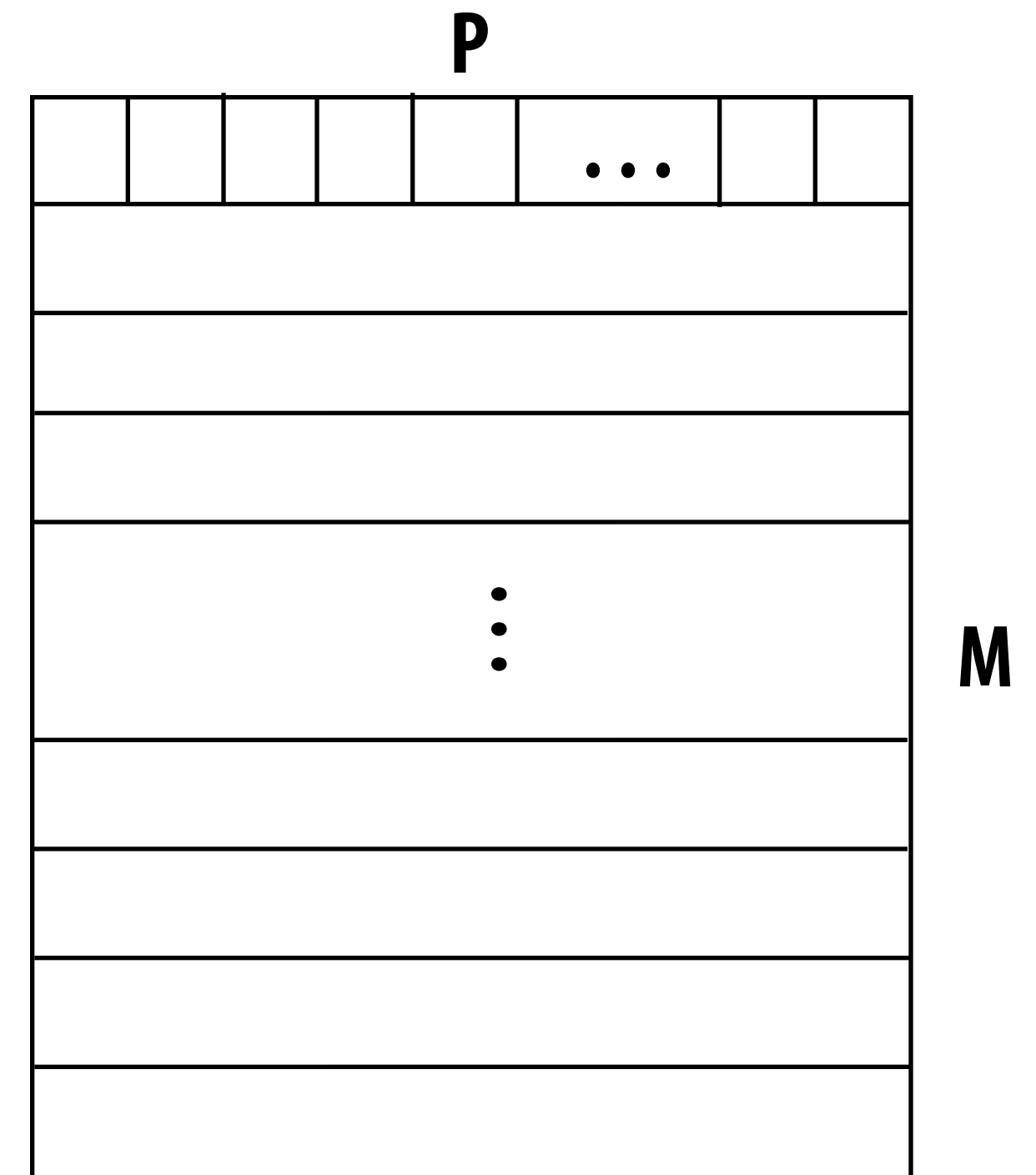

Reducing storage overhead of directory

Optimizations on full-bit vector scheme

- Increase cache line size (reduce M term)
 - What are possible problems with this approach?
(consider graphs from last lecture)
- Group multiple processors into a single directory “node” (reduce P term)
 - Need only one directory bit per node, not one bit per processor
 - Hierarchical: could use snooping protocol to maintain coherence among processors in a node, directory across nodes

We will now discuss two alternative schemes

- Limited pointer schemes (reduce P)
- Sparse directories

Limited pointer schemes

Since data is expected to only be in a few caches at once, storage for a limited number of pointers per directory entry should be sufficient (only need a list of the nodes holding a valid copy of the line!)

Example: 1024 processor system

Full bit vector scheme needs 1024 bits per line

Instead, can store ~ 100 pointers to nodes holding the line ($\log_2(1024)=10$ bits per pointer)

In practice, our workload evaluation says we can get by with far less than this

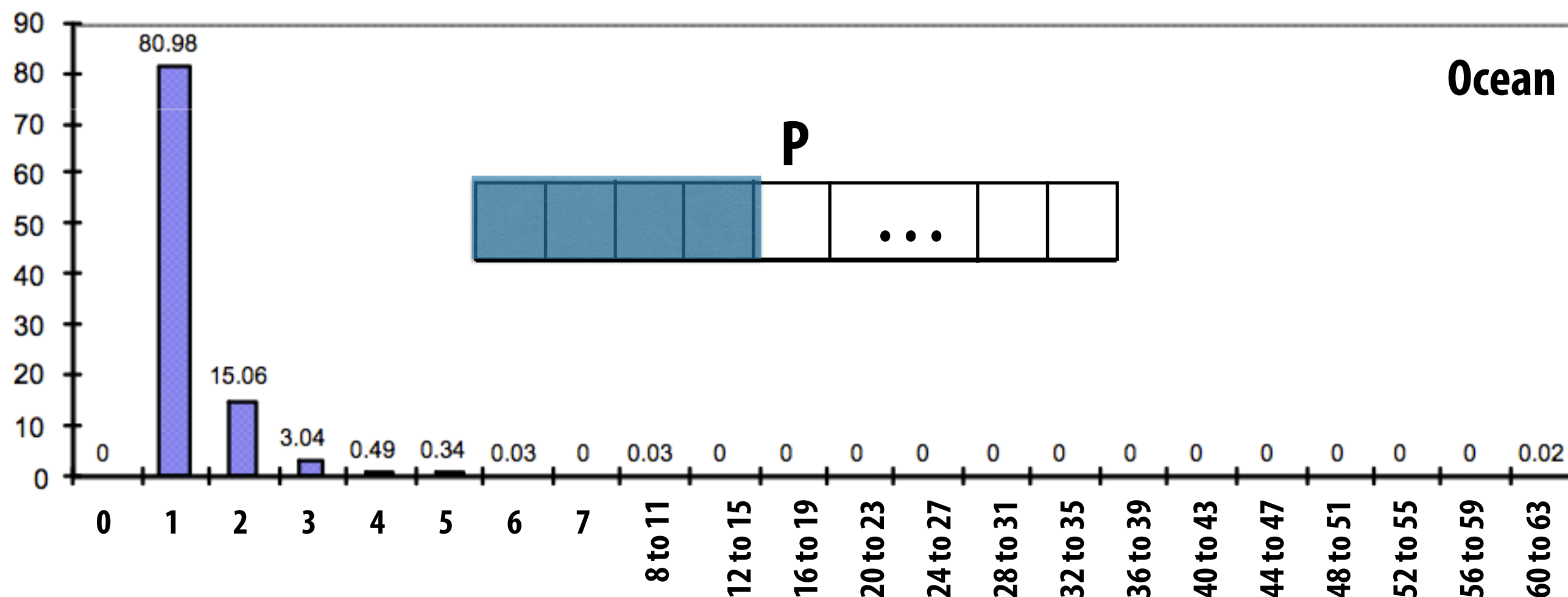

Managing overflow in limited pointer schemes

Many possible approaches

Fallback to broadcast (if broadcast mechanism exists)

- **When more than max number of sharers, revert to broadcast**

If no broadcast mechanism present on machine

- **Do not allow more than a max number of sharers**
- **On overflow, newest sharer replaces an existing one (must invalidate line in the old sharer's cache)**

Coarse vector fallback

- **Revert to bit vector representation**
- **Each bit corresponds to K nodes**
- **On write, invalidate all nodes a bit corresponds to**

Optimizing for the common case

Limited pointer schemes are a great example of smartly understanding and optimizing for the common case:

- 1. Workload-driven observation: in general the number of cache line sharers is low**
- 2. Make the common case simple and fast: array of pointers for first N sharers**
- 3. Uncommon case is still handled correctly, just with a slower, more complicated mechanism (the program still works!)**
- 4. Extra expense of the complicated solution is tolerable, since it happens infrequently**

Limited pointer schemes: summary

Limited pointer schemes reduce directory storage overhead caused by large P

- By adopting a compact representation of a list of sharers
- Entry size w/ k pointers: $1 + k \log P$ bits
- Overhead = $((1 + k \log P) * M) / (64 * 8)$
 - E.g., if $k = 5$
 - $P = 64$: 5.8 % overhead
 - $P = 256$: 7.8% overhead
 - $P = 1024$: 9.7% overhead

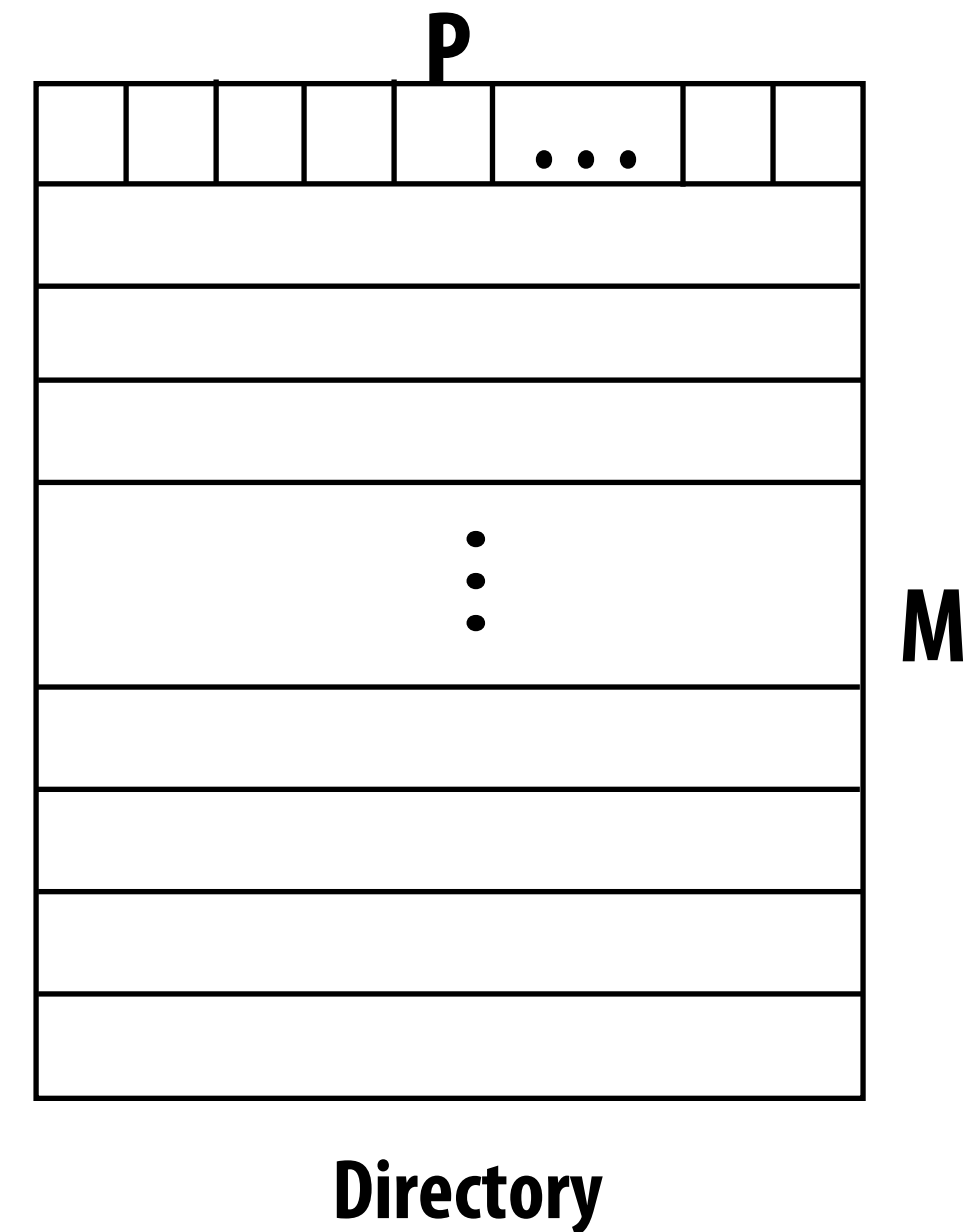

Lines have a few sharers, works well in practice

But do we really even need to maintain a list of shares for each cache-line chunk of data in memory?

Limiting size of directory: sparse directories

Key observation: the majority of memory is NOT resident in cache. And to carry out coherence protocol the system only needs sharing information for lines that are currently in cache

- Most directory entries are empty most of the time
- 1 MB cache, 1 GB memory per node → 99.9% of directory entries are empty

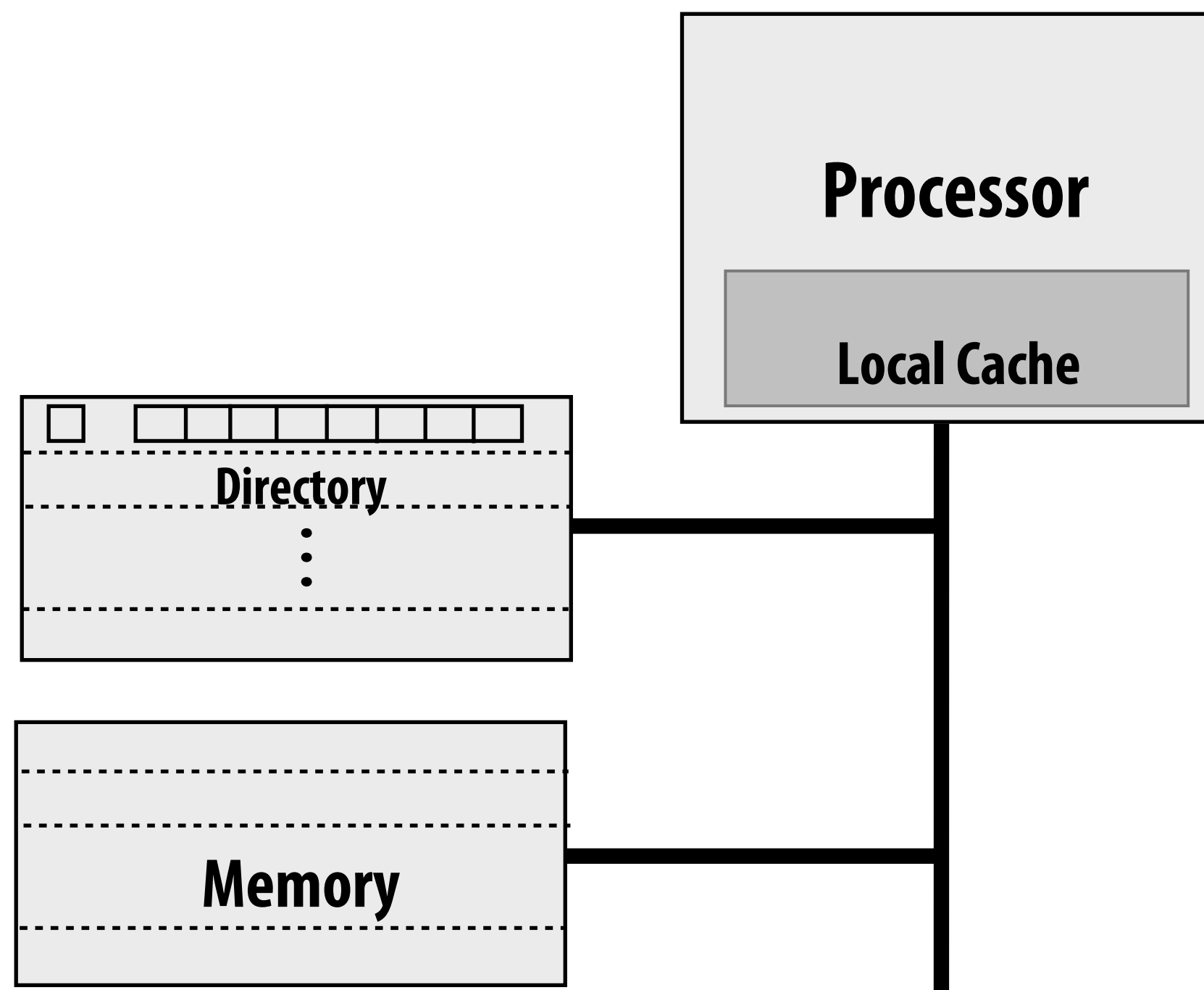

Limiting size of directory: sparse directories

Key observation: the majority of memory is NOT resident in cache. And to carry out coherence protocol the system only needs sharing information for lines that are currently in cache

- Most directory entries are empty most of the time
- 1 MB cache, 1 GB memory per node → 99.9% of directory entries are empty

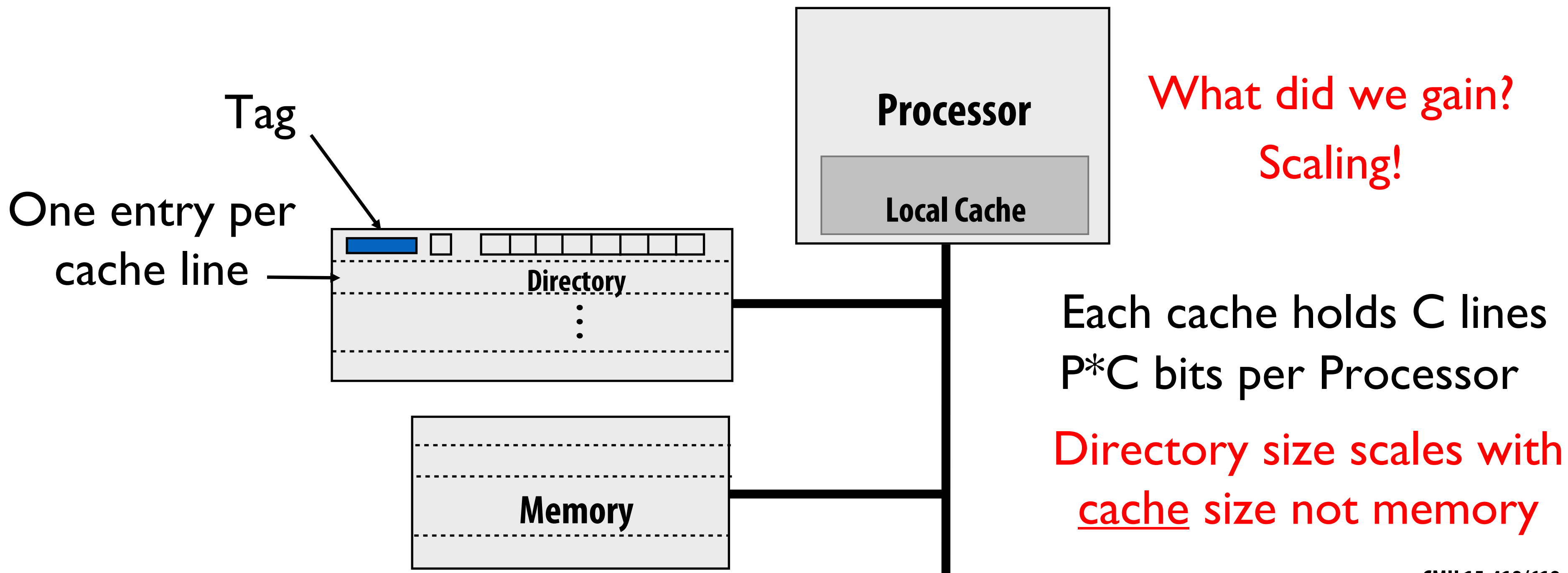

Limiting size of directory: sparse directories

Key observation: the majority of memory is NOT resident in cache. And to carry out coherence protocol the system only needs sharing information for lines that are currently in cache

- Most directory entries are empty most of the time
- 1 MB cache, 1 GB memory per node → 99.9% of directory entries are empty

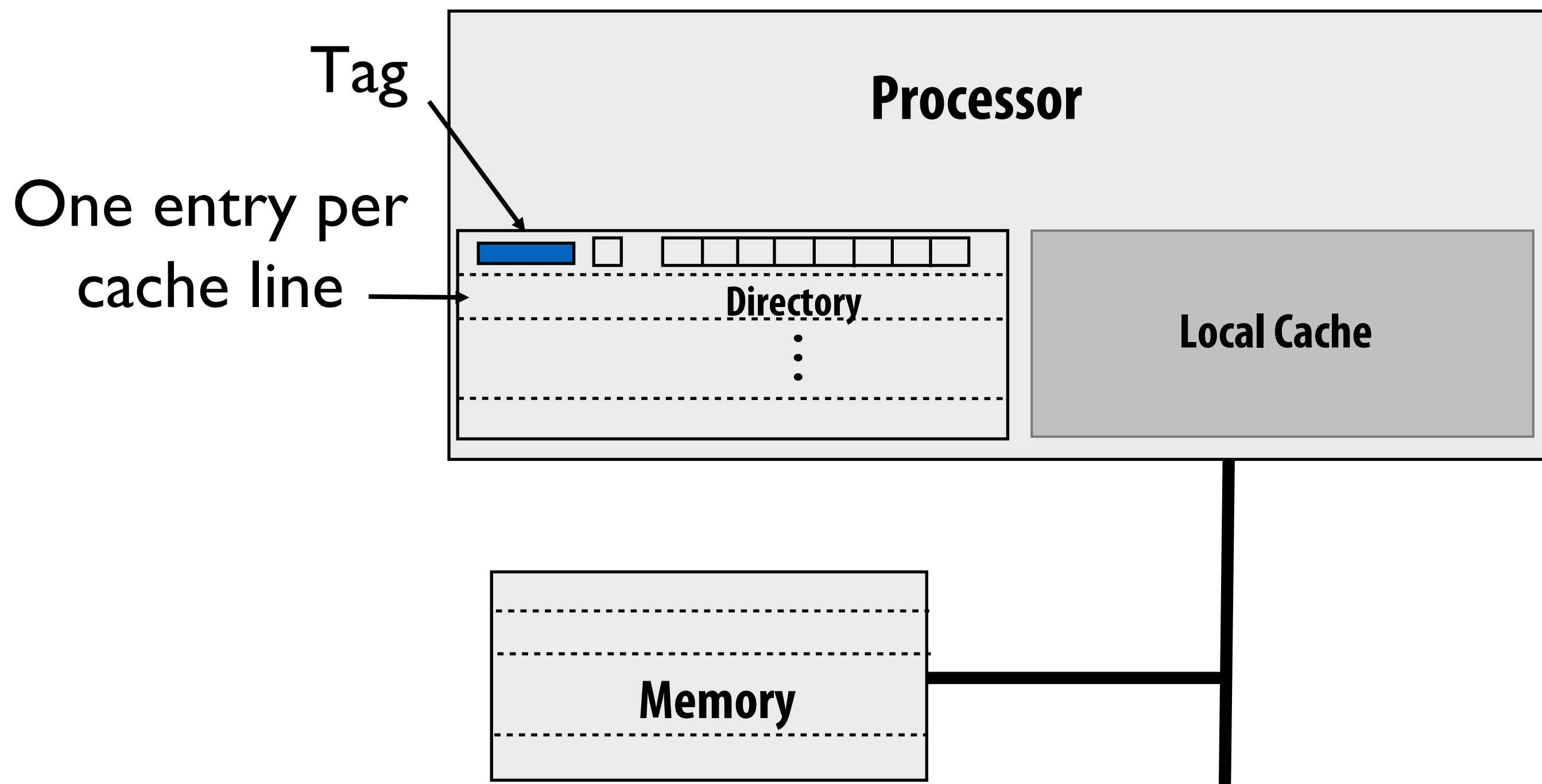

Sparse directories

Directory at home node maintains pointer to only one node caching line (not a list of sharers)

Pointer to next node in list is stored as extra information in the cache line (just like the line's tag, dirty bits, etc)

On read miss: add requesting node to head of list

On write miss: propagate invalidations along list

On evict: need to patch up list (linked list removal)

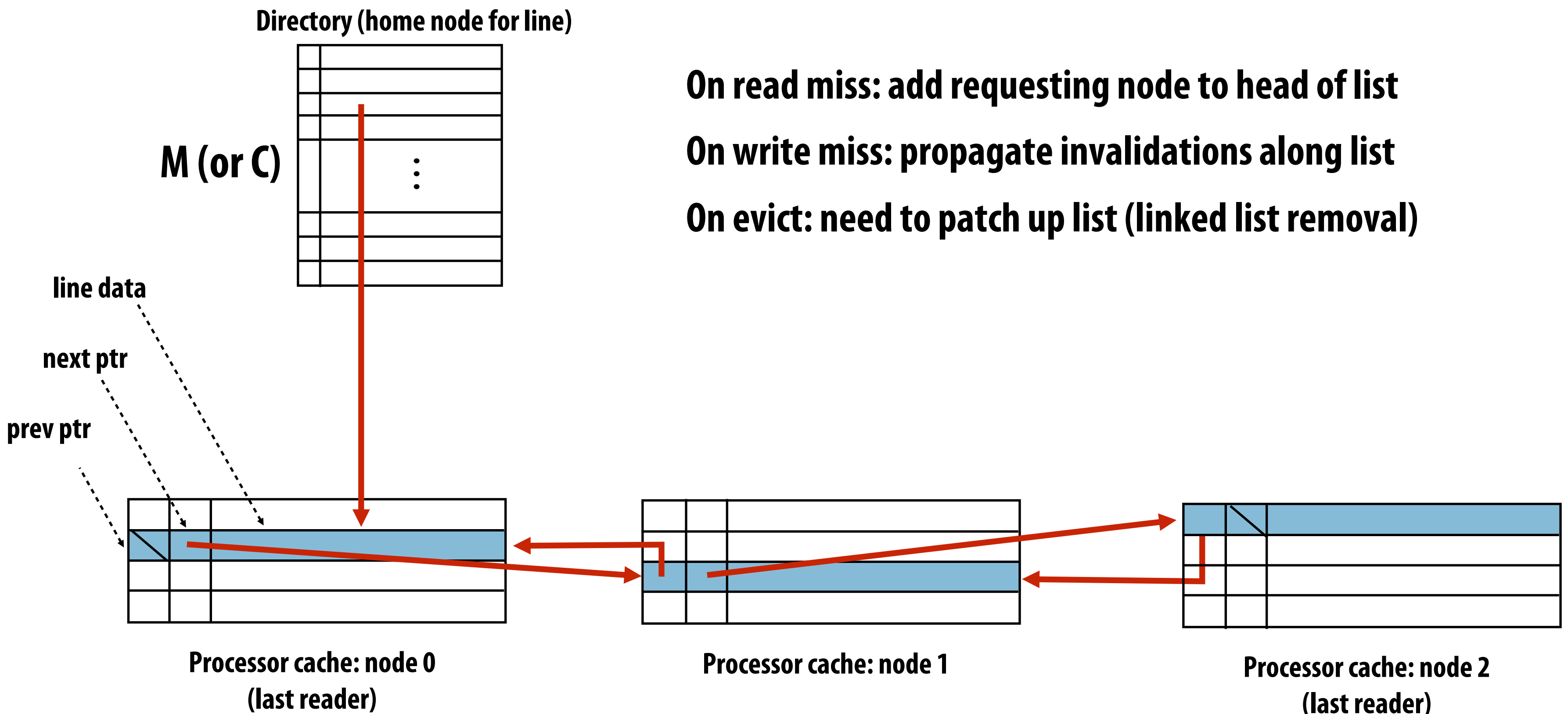

Sparse directories: scaling properties

Good:

- Low memory storage overhead (one pointer to list head per line)
- Additional directory storage is proportional to cache size (the list stored in SRAM)
- Traffic on write is still proportional to number of sharers

Bad:

- Latency of write proportional to number of sharers (invalidation of lines is serial)
- Higher implementation complexity

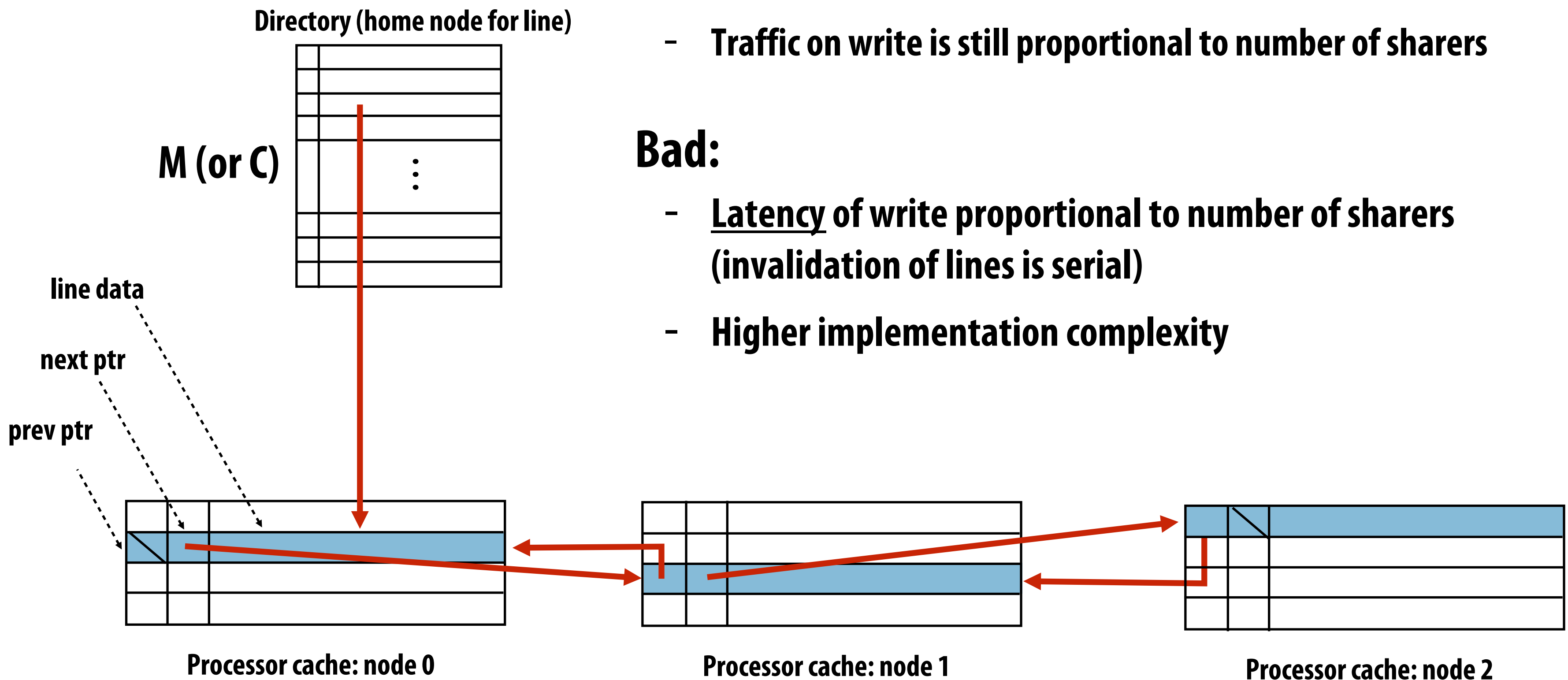

Recall: write miss in full bit vector scheme

Write to memory by processor 0: line is clean, but resident in P1's and P2's caches

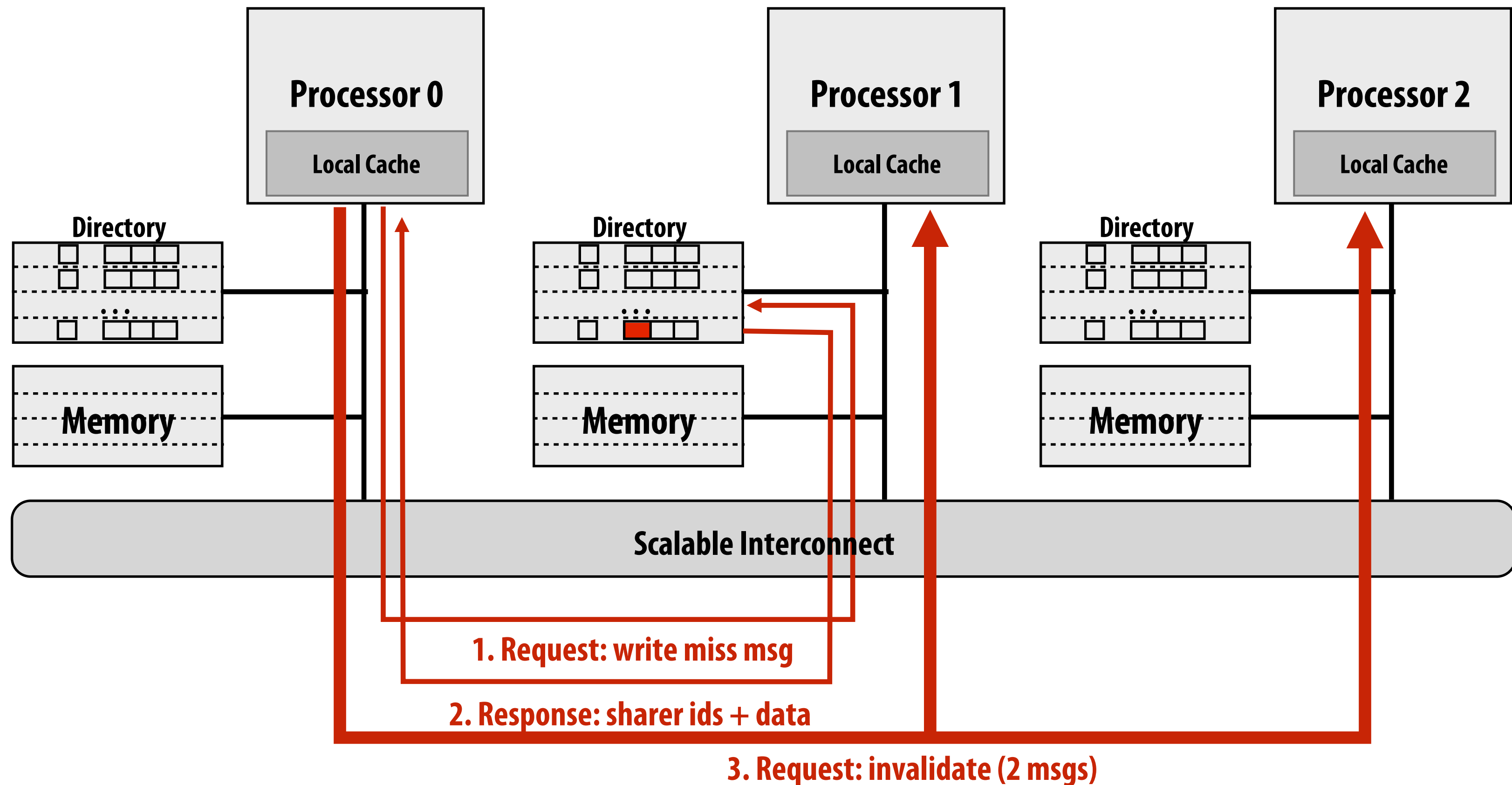

Original bit-vector scheme sends same number of invalidation messages as sparse directory approach, but invalidation messages can be sent to all processors in parallel

Optimizing directory-based coherence

Reducing storage overhead of directory data structure

- Limited pointer schemes
- Sparse directories

Reducing number of messages sent to implement coherence protocol

Recall: read miss to dirty line

Read from main memory by processor 0 of the blue line: line is dirty (contained in P2's cache)

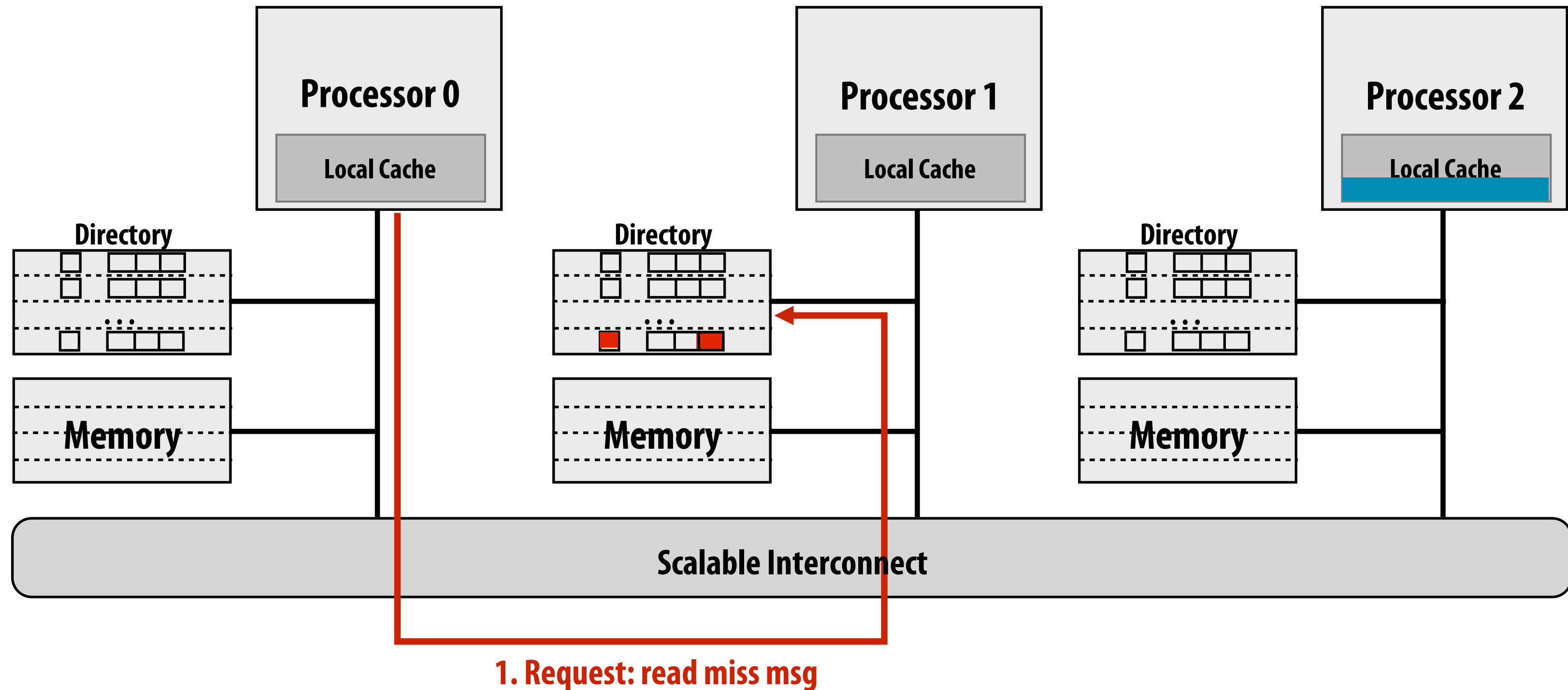

Recall: read miss to dirty line

Read from main memory by processor 0 of the blue line: line is dirty (contained in P2's cache)

(Note: figure below shows final state of system after operation is complete)

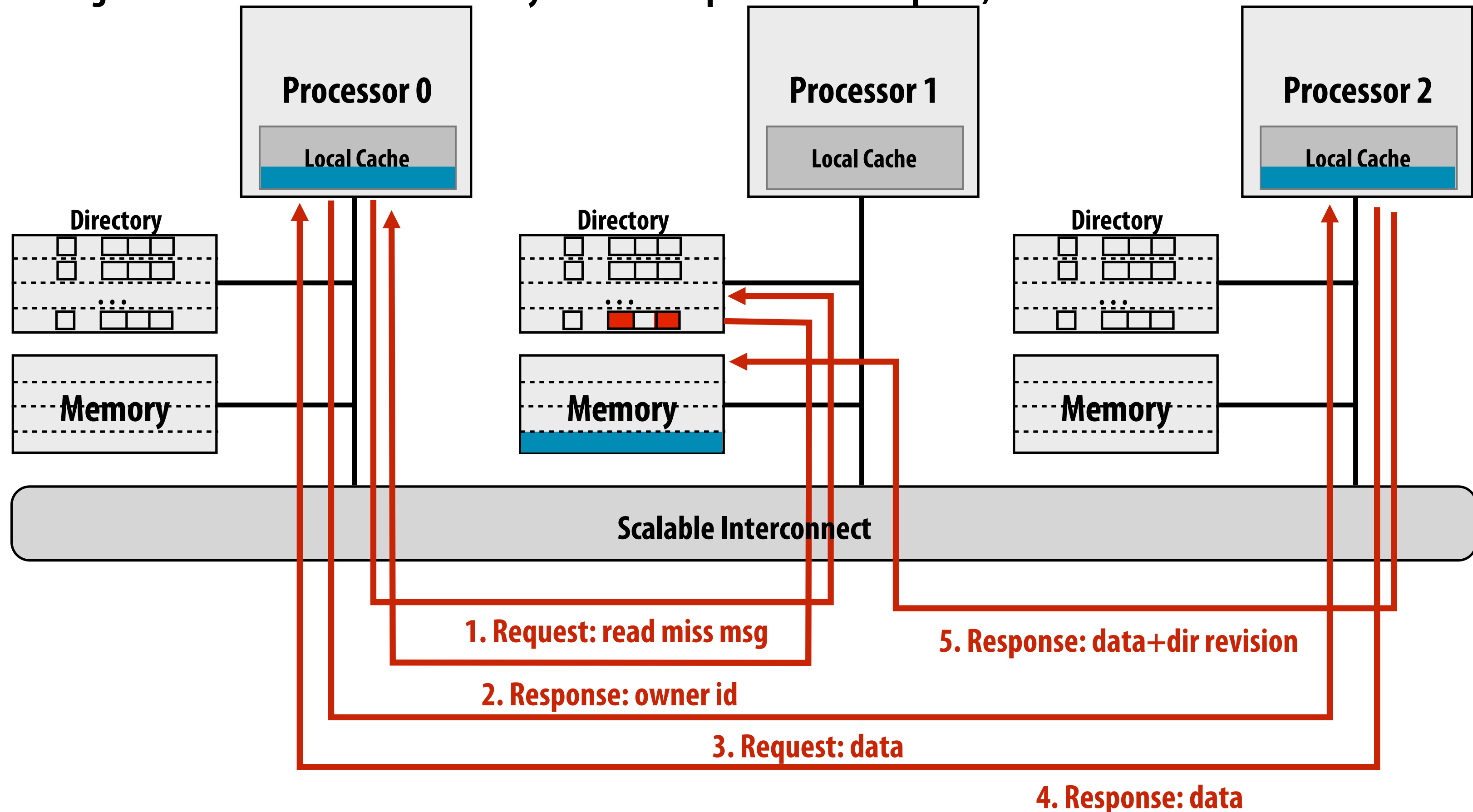

Five network transactions in total

Four of the transactions are on the "critical path" (transactions 4 and 5 can be done in parallel)

- Critical path: sequence of dependent operations that must occur to complete operation

Intervention forwarding

Read from main memory by processor 0 of the blue line: line is dirty (contained in P2's cache)

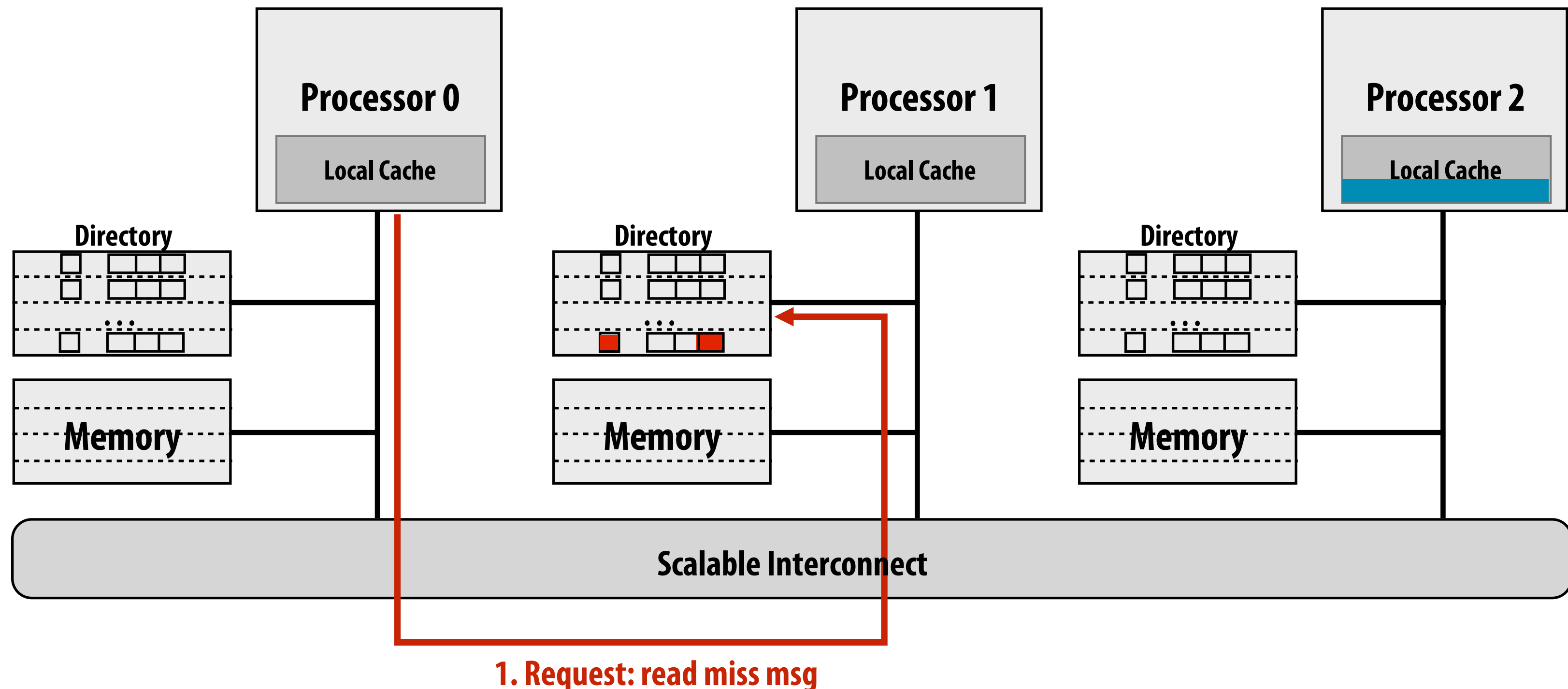

Intervention forwarding

Read from main memory by processor 0 of the blue line: line is dirty (contained in P2's cache)

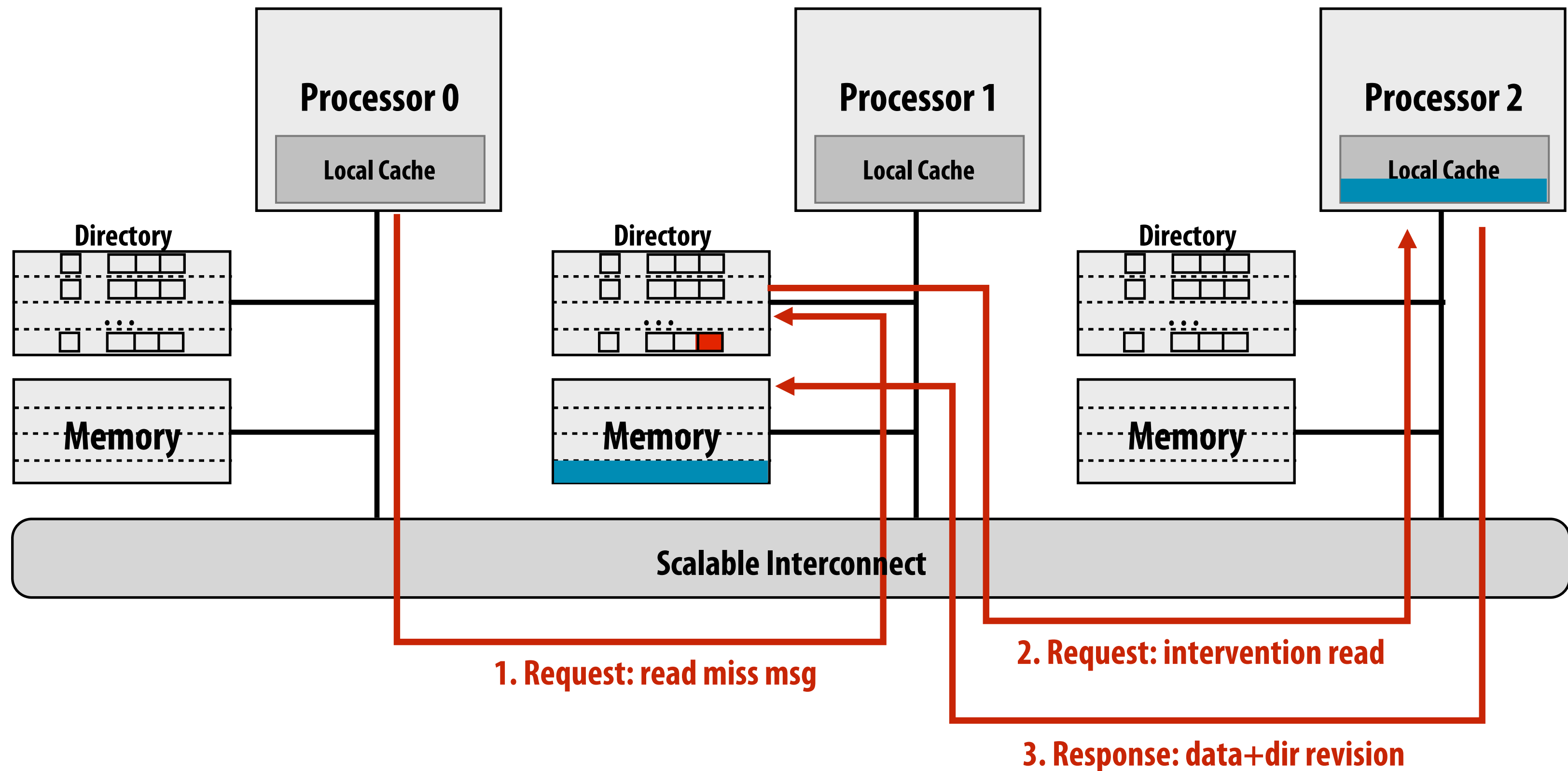

2. Home node requests data from owner node (processor 2)
3. Owning node responds

Intervention forwarding

Read from main memory by processor 0 of the blue line: line is dirty (contained in P2's cache)

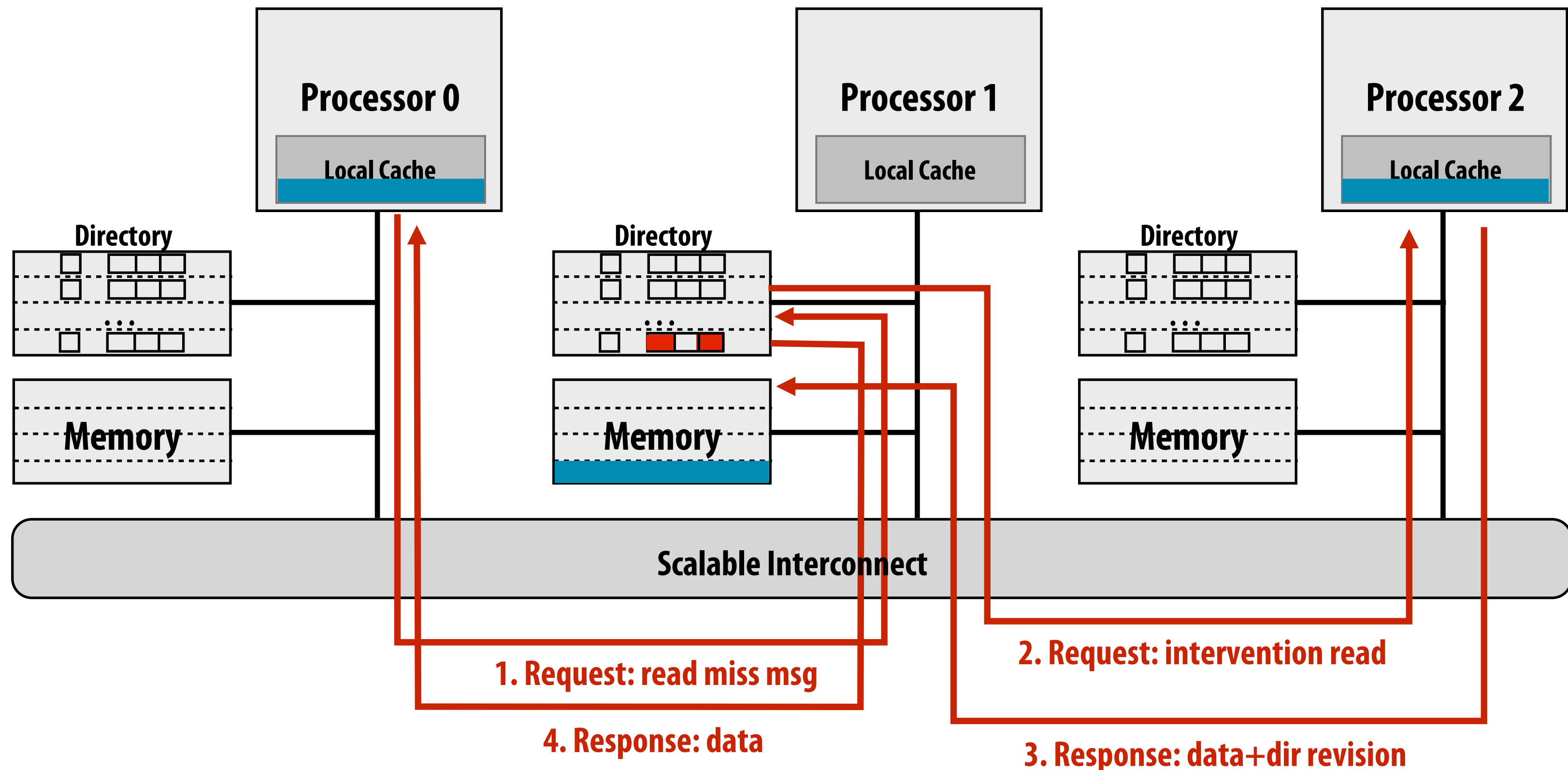

4. Home node updates directory, and responds to requesting node with data

Four network transactions in total (less traffic)

But all four of the transactions are on the "critical path." Can we do better?

Request forwarding

Read from main memory by processor 0 of the blue line: line is dirty (contained in P2's cache)

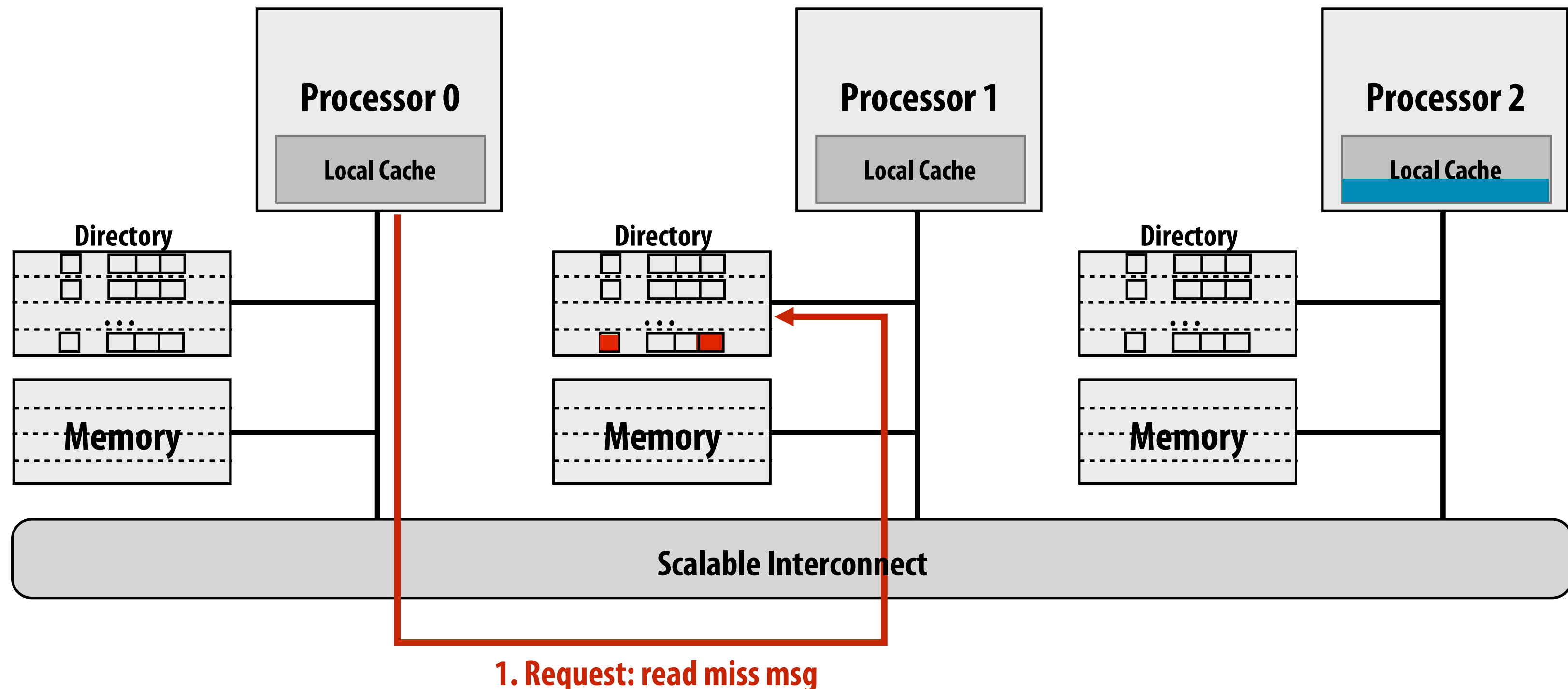

Request forwarding

Read from main memory by processor 0 of the blue line: line is dirty (contained in P2's cache)

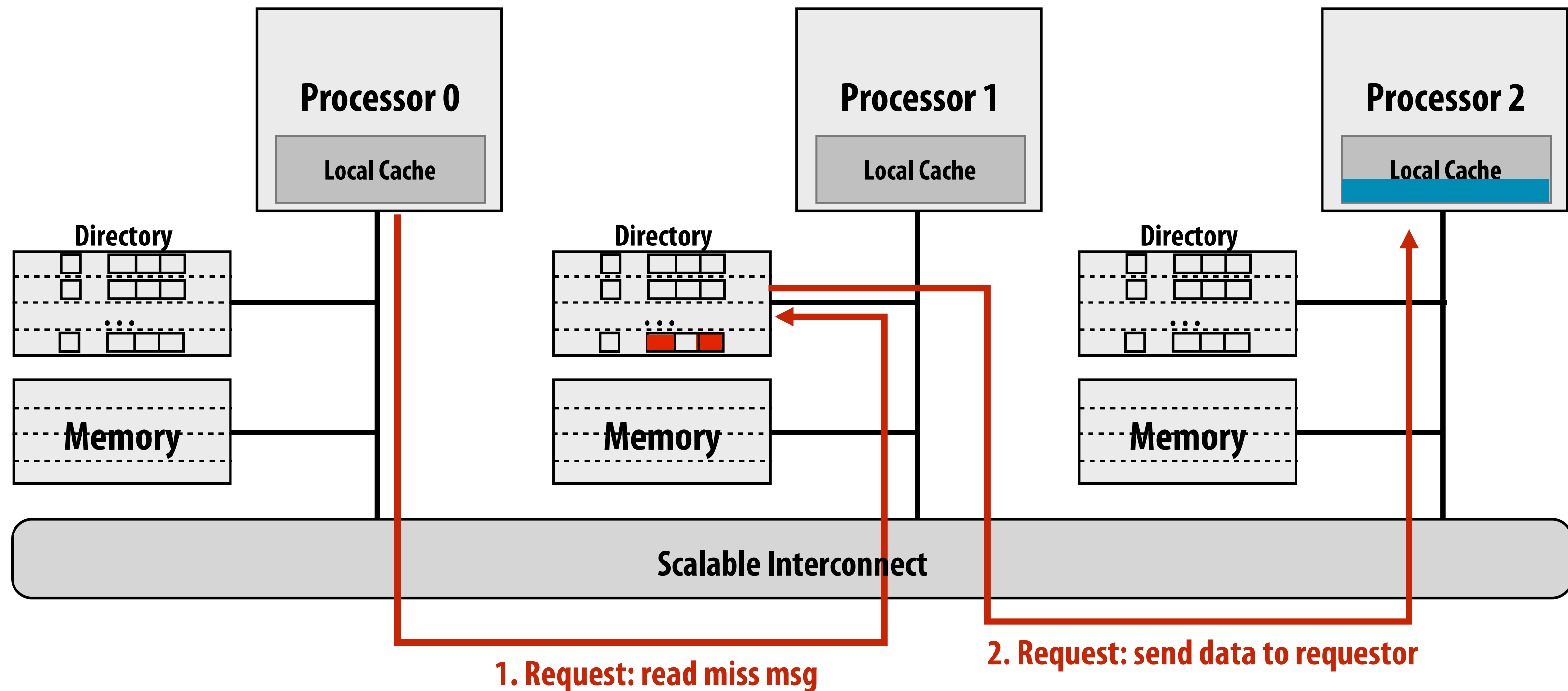

Request forwarding

Read from main memory by processor 0 of the blue line: line is dirty (contained in P2's cache)

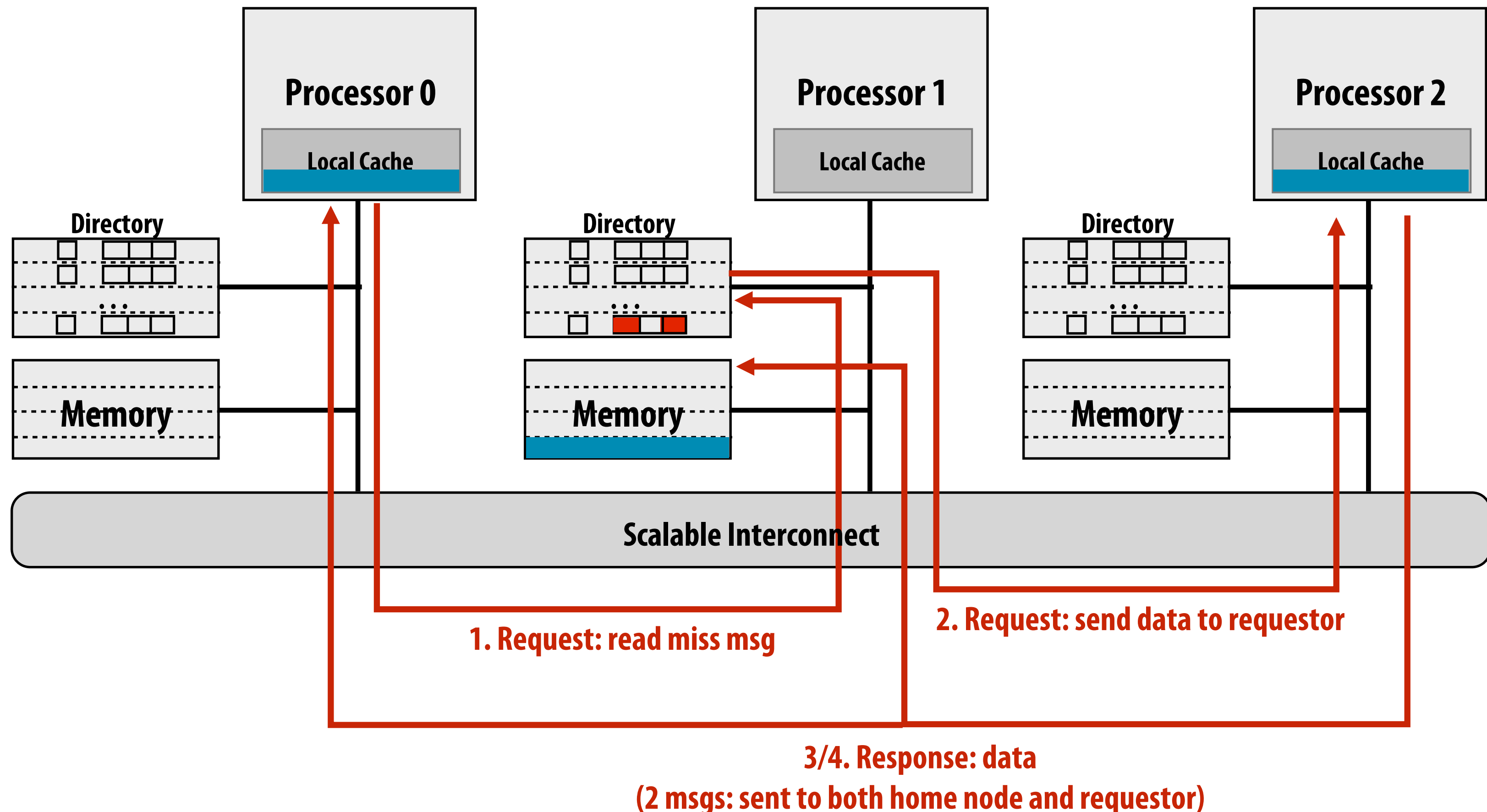

Four network transactions in total

Only three of the transactions are on the critical path (transactions 3 and 4 can be done in parallel)

Note: system is no longer pure request/response (since P0 sent request to P1, but receives response from P2)

Directory coherence in Intel Core i7 CPU

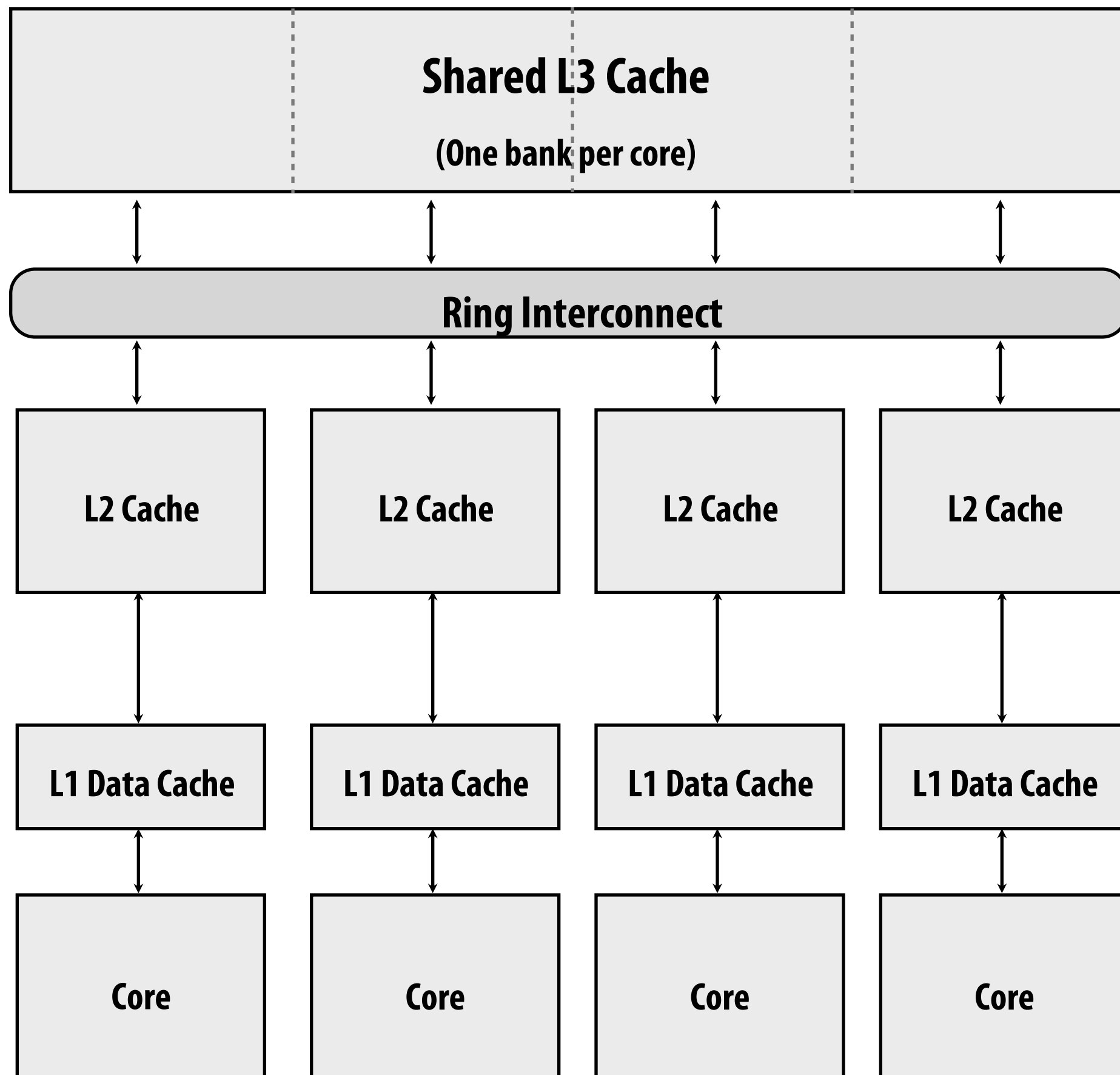

L3 serves as centralized directory for all lines in the L3 cache

(note importance of inclusion property... there will be a directory entry for any line in an L2)

Directory maintains list of L2 caches containing line
Instead of broadcasting coherence traffic to all L2's, only send coherence messages to L2's that contain the line

(Core i7 interconnect is a ring, it is not a bus)

Directory dimensions:

- $P=4$
- $C = \text{number of L3 cache lines}$

Coherence in multi-socket Intel systems

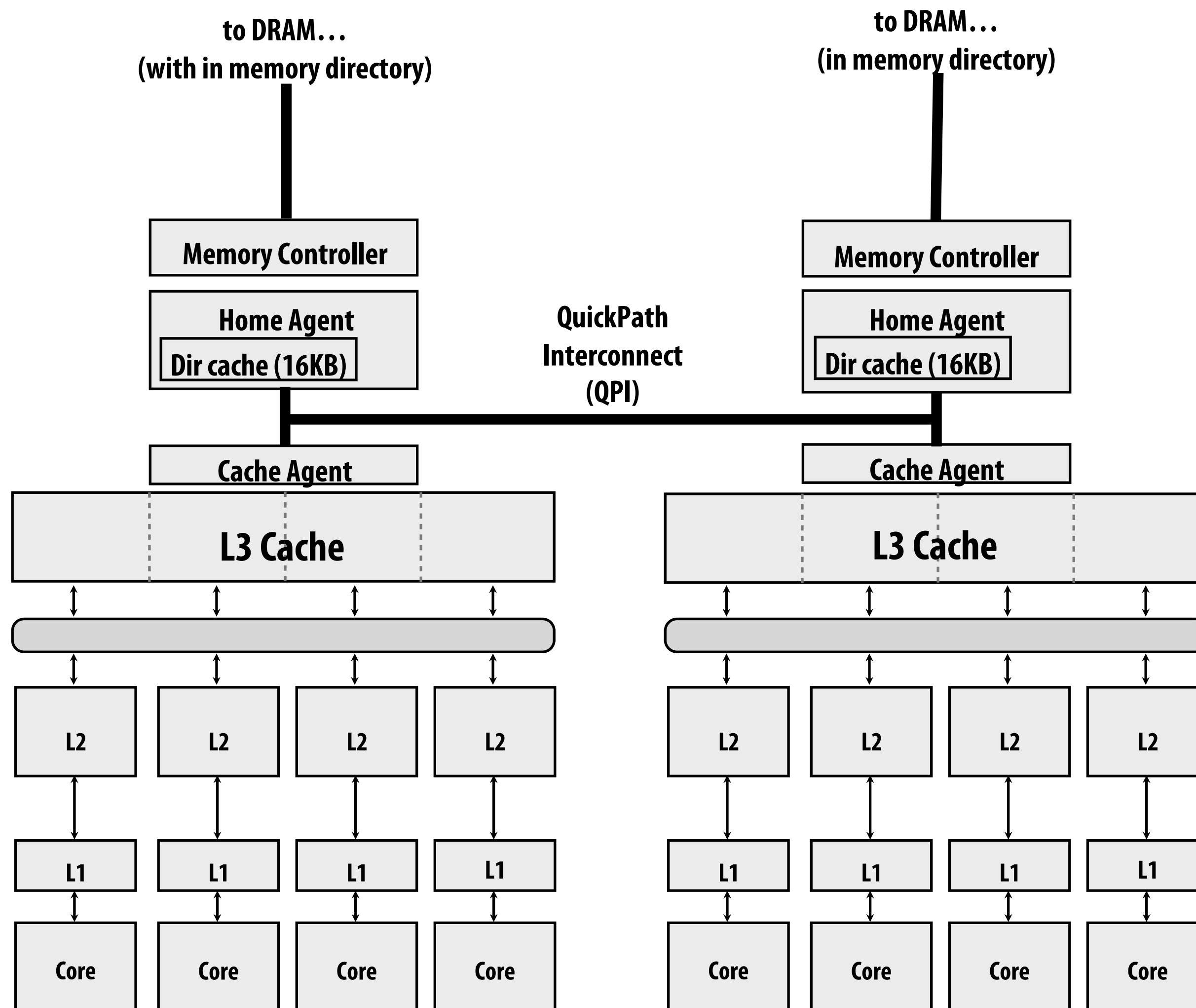

L3 directory reduces on-chip coherence traffic (previous slide)
In-memory directory (cached by home agent/memory controller) reduces coherence traffic between cores

Summary: directory-based coherence

Primary observation: broadcast doesn't scale, but luckily we don't need to broadcast to ensure coherence because often the number of caches containing a copy of a line is small

Instead of snooping, just store the list of sharers in a "directory" and check the list as necessary

One challenge: reducing overhead of directory storage

- **Use hierarchies of processors or larger line sizes**
- **Limited pointer schemes: exploit fact the most processors not sharing line**
- **Sparse directory schemes: exploit fact that most lines are not in cache**

Another challenge: reducing the number of messages sent (traffic) and critical path (latency) of message chains needed to implement coherence operations

Quiz Time